

REV	DESCRIPTION	DATE
G	REDESIGNED NOSE ASSEMBLY	10/22/09
H	122125 UNITIZED JAWS WAS 129358 ADDED 89177 SPACER	11/11/09

NOTES:

1 SHIP WITH P/N 114431 PINTAIL TUBE.

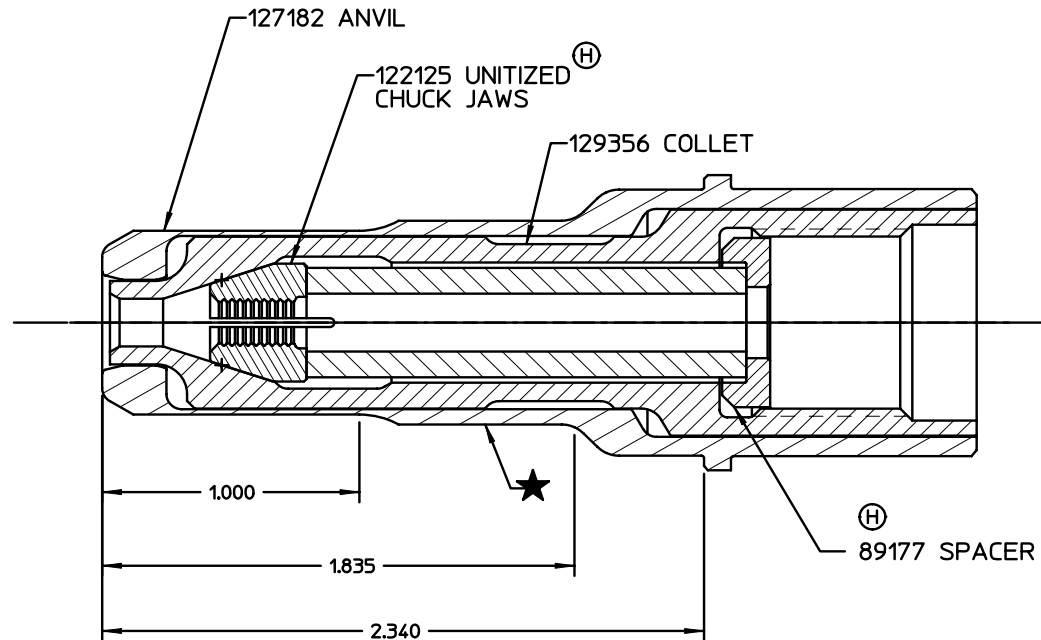
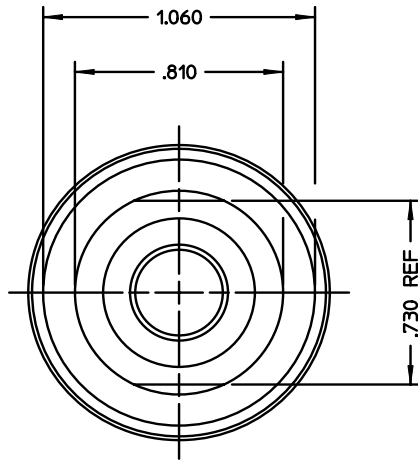

FORM: KE104 REV D		By accepting this proprietary Huck drawing, recipient agrees not to reproduce or disclose any part thereof to any others without the written permission of Huck International, Inc.			
ITAR:	ECCN: EAR99	SCH B#:	8467.99.0190	HTS:	8467.99.0190
MATERIAL:	-	SPEC:	TOLERANCES UNLESS OTHERWISE SPECIFIED:	HUCK INTERNATIONAL, INC., I.S.D. 1 CORPORATE DRIVE, P.O. BOX 2270 KINGSTON, NEW YORK 12401	
HARDNESS:	-	(RAW OR STOCKED STATE)	(ALL DIMENSIONS ARE IN INCHES)	NOSE ASSEMBLY	
HEAT TREAT TO:	-	SPEC:	.XX, .XXX ±	.01, .005	-08 BOM
SURFACE TREAT:	-	SPEC:	INT. COR. RADII	.005-.015	
SURFACE FINISH NOT TO EXCEED:	125 Ra		BREAK EDGES	.005-.015	DET: CHR CK: DATE: 10/22/09 SCALE: 2:1
IDENTIFICATION PER SPEC 42-311:	★ PERMANENT		ANGLES ±	3°	
SURFACES TO BE	○, //, ⊕, ⊥, & ☐ WITHIN .005 T.I.R.		FINAL ASSY:	245,353,2580	B 99-830-1

Contact Applifast

Tel 204 837 8361 • 1 800 563 1293
info@applifast.com



applifast.com