

REV	DESCRIPTION	DATE
A	RELEASE	10/22/09

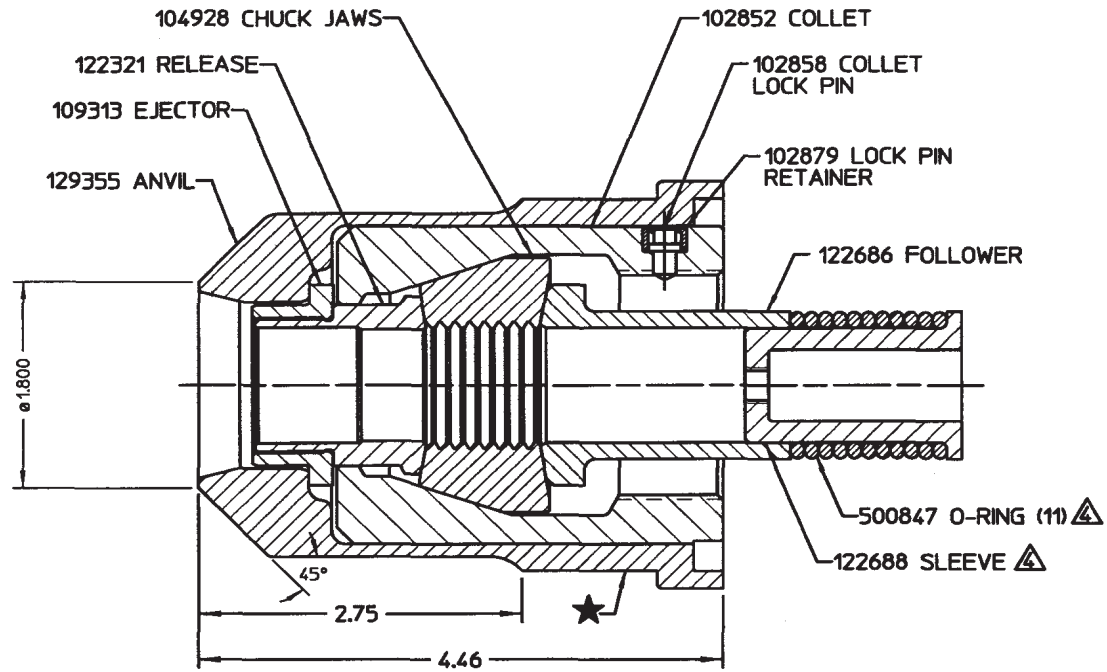
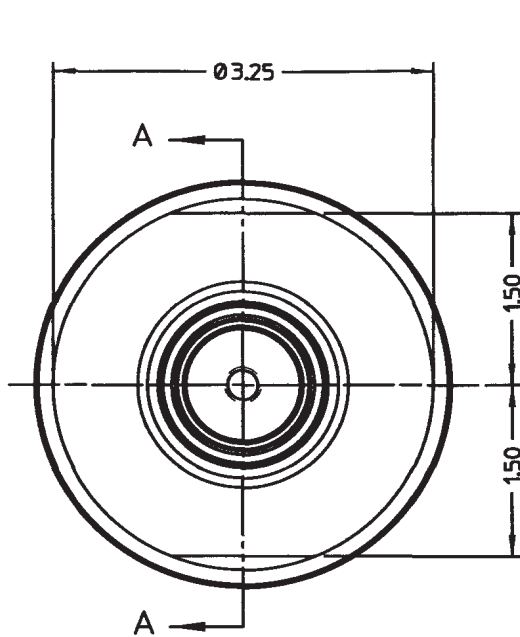

SECTION A-A

NOTES:

- COLLET & LOCK ASSEMBLY P/N 102914 CONSISTS OF:  
102852 COLLET (NOT AVAILABLE SEPARATELY),  
102858 COLLET LOCK PIN  
102879 RETAINER  
122321 RELEASE  
109313 EJECTOR
- RELEASE & EJECTOR KIT P/N 122322 CONSISTS OF:  
122321 RELEASE  
109313 EJECTOR  
503657 LOCTITE
- SHIP WITH CAUTION TAG P/N 590152.

⚠ ASSEMBLE SLEEVE & O-RINGS PER HUCK SPEC 42-491.

FORM 9804 REV D		By accepting this proprietary Huck drawing, recipient agrees not to reproduce or disclose any part thereof to any others without the written permission of Huck International, Inc.	
ITAR:	ECCN: EAR99	SCH B#: 8467.99.0190	HTS: 8467.99.0190
MATERIAL:	SPEC:	TOLERANCES UNLESS OTHERWISE SPECIFIED:	HUCK INTERNATIONAL, INC., I.S.D.
HARDNESS:	ORAW OR STOCKED STATE	XX, XXX : .01, .005	1 CORPORATE DRIVE, P.O. BOX 2270
HEAT TREAT TO:	SPEC:	INT. COR. RADI : .005-.015	KINGSTON, NEW YORK 12401
SURFACE TREAT:	SPEC:	BREAK EDGES : .005-.015	NOSE ASSEMBLY CLEARANCE -32 C50L
SURFACE FINISH NOT TO EXCEED: 125 Rd		ANGLES : 3°	DET: CHR/CK: DATE: 10/22/09 SCALE: 1:1
IDENTIFICATION PER SPEC 42-31: ★ PERMANENT		FINAL ASSY:	B
SURFACES TO BE ○, //, ◆, ⊥, & □ WITHIN .005 T.I.R.		99-5016-1	

Contact Applifast

Tel 204 837 8361 • 1 800 563 1293  
info@applifast.com



applifast.com