

REV	DESCRIPTION	DATE
K	ADDED 127776 SPACER	05/03/05

NOTES:

- SHIP WITH O-RING P/N 500778.
- BEFORE ATTACHING NOSE ASSEMBLY TO TOOL, INSTALL SUPPLIED O-RING ON TO THREAD RELIEF OF PULL PISTON.

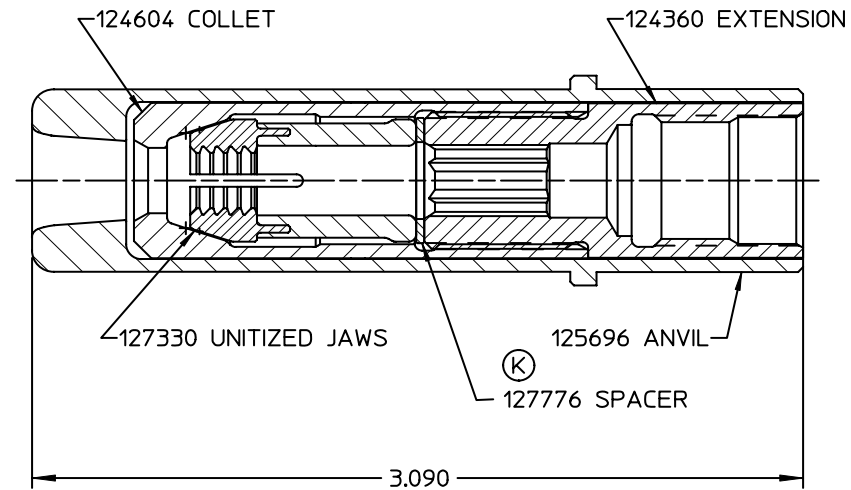
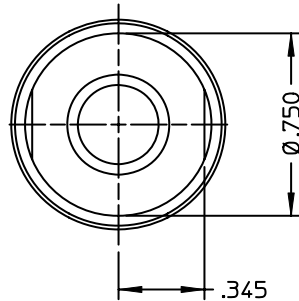
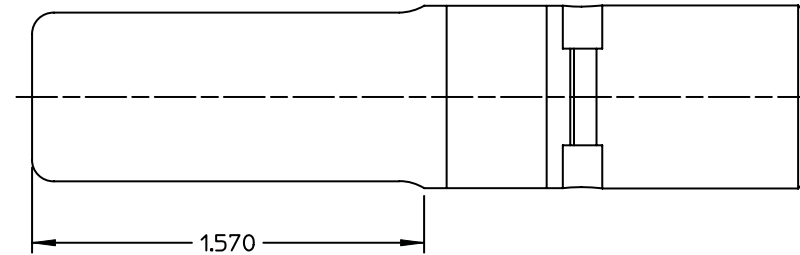

HUCK INTERNATIONAL, INC., I.S.D. 1 CORPORATE DRIVE, KINGSTON, NEW YORK 12401		
NOSE ASSEMBLY -08 MG		
DET: CHR. CK:	DATE: 05/03/05	SCALE: 2/1
FOC. FAC.	B	99-1458

FORM: KE104 REV C

By accepting this proprietary Huck drawing, recipient agrees not to reproduce or disclose any part thereof to any others without the written permission of Huck International, Inc.

Contact Applifast

Tel 204 837 8361 • 1 800 563 1293
info@applifast.com



applifast.com