

REV	DESCRIPTION	DATE
H	126001 CHUCK JAWS WAS 117760 AND UPDATE PICTORIALY COLLET	02/01/00
J	127331 JAW WAS 126001 JAW PICTORIALY UPDATED 115826 COLLET	09/05/03

NOTES:

- SHIP WITH O-RING P/N 500778.
- BEFORE ATTACHING NOSE ASSEMBLY TO TOOL, INSTALL SUPPLIED O-RING ON TO THREAD RELIEF OF PULL PISTON.

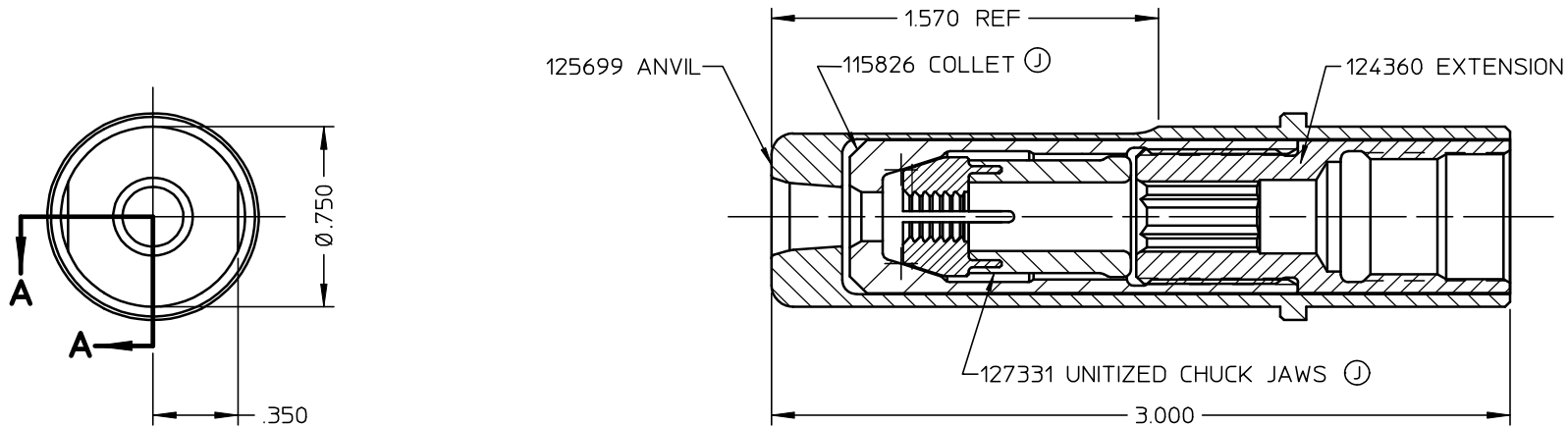

SECTION A-A

FORM KE104 REV C		By accepting this proprietary Huck drawing, recipient agrees not to reproduce or disclose any part thereof to any others without the written permission of Huck International, Inc.	
MATERIAL: -	SPEC: -	TOLERANCES UNLESS OTHERWISE SPECIFIED	
HARDNESS: -		XX, .XXX ±	HUCK INTERNATIONAL, INC., I.S.D. 1 CORPORATE DRIVE, P.O. BOX 2270 KINGSTON, NEW YORK 12401
HEAT TREAT: -	SPEC: -	INT. COR. RADII	
SURF. TREAT: -	SPEC: -	BREAK EDGES	NOSE ASSEMBLY -06 MG
SURFACE FINISH NOT TO EXCEED Ra		ANGLES ±	DET: PRS CK: DATE: 07/29/94 SCALE: 2:1
IDENTIFICATION PER SPEC 42-311: ★ CHEMICAL ETCH		T.I.R. FINAL ASSY: -	FOC: FAC: B 99-1456
SURFACES TO BE ©, //, ⊕, L, & □ WITHIN			

Contact Applifast

Tel 204 837 8361 • 1 800 563 1293
 info@applifast.com



applifast.com