

**Alcoa  
Fastening  
Systems**

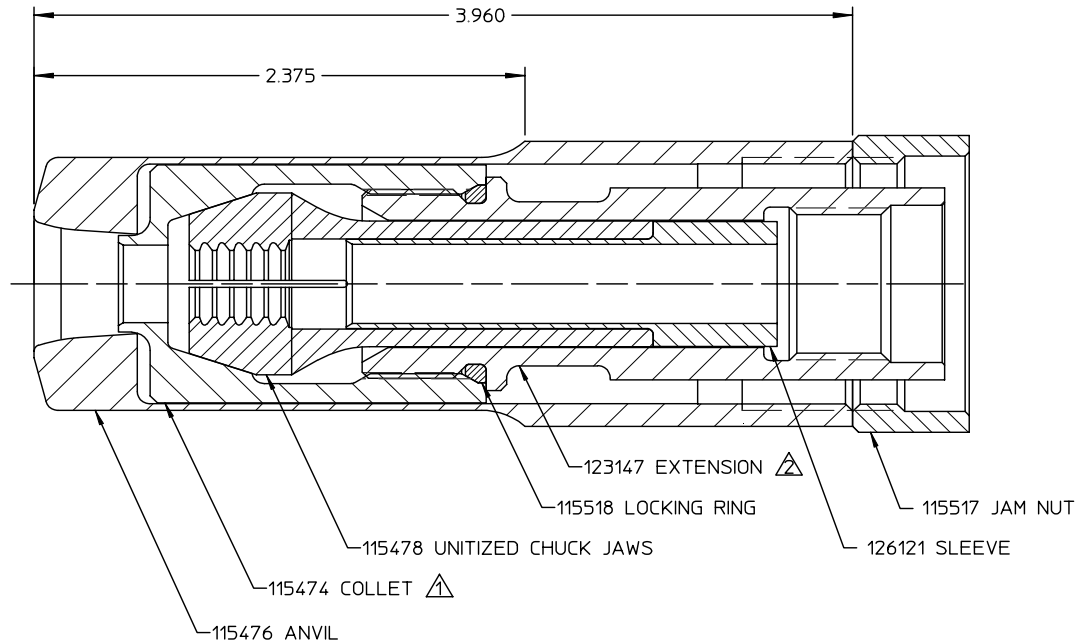

## DATA SHEET

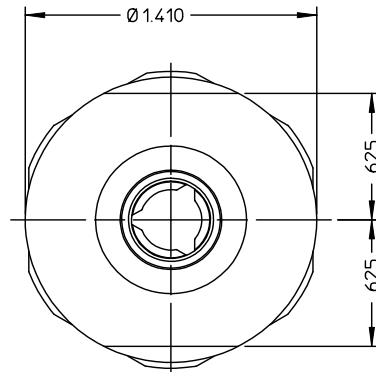

<b>99-1450</b> Part Number	<b>Alcoa Fastening Systems</b> Commercial Products 1 Corporate Drive, Kingston, NY 12401	
	NOSE TYPE:	NON-SELF-RELEASING
	FASTENER TYPE:	-12 MG
	TOOL(S):	246, 2502, 4801, 4802
	Notes:	Product Revision: <b>F</b>
	US Patent:	Date: 06/18/03

NOTES:

- ▲ TORQUE TO 60 FTLBS MIN
- ▲ FOR SERVICE ORDER EXTENSION LOCK RING ASSEMBLY P/N 115516.
- 3 INCLUDE P/N 115738 SPACER, FOR USE WITH 4801 TOOL.

**Contact Applifast**

Tel 204 837 8361 • 1 800 563 1293  
info@applifast.com



[applifast.com](http://applifast.com)