

By accepting this proprietary Huck drawing, recipient agrees not to reproduce or disclose any part thereof to any others without the written permission of Huck International, Inc.

REV	DESCRIPTION	DATE
F	REDRAWN WITH NEW BORDER	06-16-92
G	P/N 122739 WAS 113929.	-

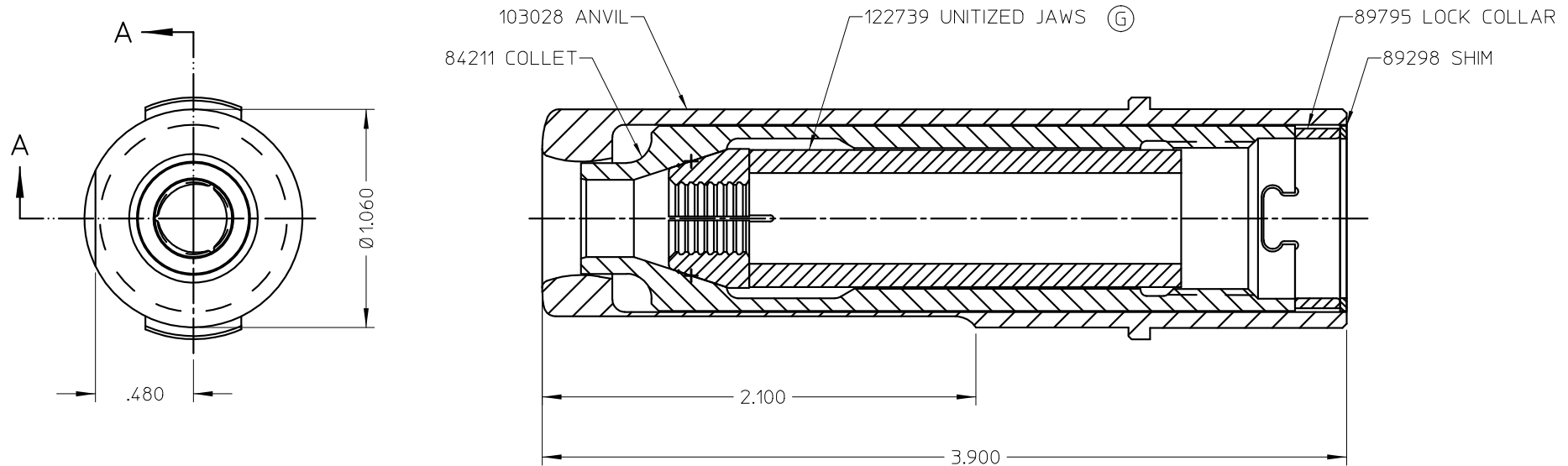

SECTION A-A

MATERIAL:	-	SPEC: -	TOLERANCES UNLESS OTHERWISE SPECIFIED	HUCK INTERNATIONAL, INC., I.E.D. 85 GRAND STREET, P.O. BOX 2270 KINGSTON, NEW YORK 12401			
HARDNESS:	-			NOSE ASSEMBLY			
HEAT TREAT:	-	SPEC: -	.XX, .XXX ±	-12 C6L			
SURF. TREAT:	-	SPEC: -	INT. COR. RADII				
SURFACE FINISH NOT TO EXCEED		Ra	BREAK EDGES	DET:SMR	CK:	DATE: 6-16-92	SCALE: 2/1
IDENTIFICATION PER SPEC 42-311: ★ CHEMICAL ETCH			ANGLES ±	FOC.	B	99-100	
SURFACES TO BE ©, //, ⊕, ⊥, & ▽ WITHIN -			T.I.R. FINAL ASSY: -	FAC.			

**Contact Applifast**

Tel 204 837 8361 • 1 800 563 1293  
info@applifast.com



[applifast.com](http://applifast.com)