

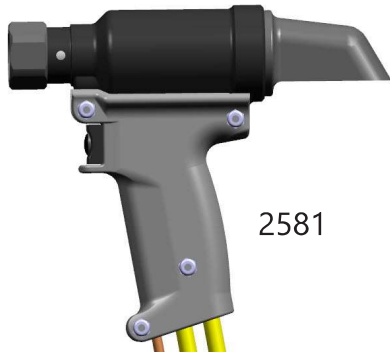

Instruction Manual

2581, 2582, and 2583 series Hydraulic Installation Tools



2581

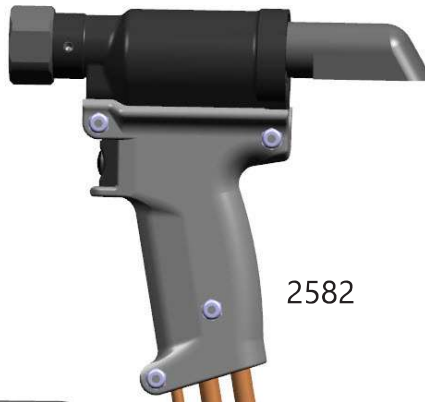

2582

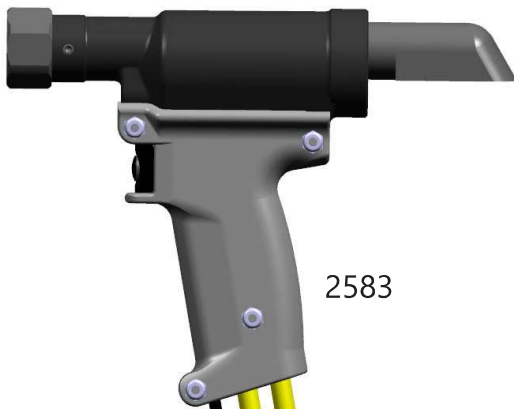

2583

Declaration of Conformity	2
Safety Instructions	3-4
Description	5
Specifications	5
Principle of Operation	6
Tool Set-up	6
Optional Equipment	7
Sticker Locations	7
Preparation for Use	8
Operating Instructions	9
Hydraulic Fittings	9
Maintenance	10
Disassembly and Assembly	11-12
Components Drawings	13-17
Troubleshooting	18



HUCK IS FOREVER.



**HOWMET
AEROSPACE**

EC Declaration of Conformity

Manufacturer:

Howmet Aerospace, LLC, Industrial Products Group, 1 Corporate Drive, Kingston, NY, 12401, USA

Description of Machinery:

Models 2400, 2480, 2500, 2580 family of hydraulic installation tools and specials based on their design (e.g. PR# # # #).

Relevant provisions complied with:

Council Directive related to Machinery (2006/42/EC)

British Standard related to hand held, non-electric power tools (ISO 11148-1:2011)

European Representative:

Paul Carson, Howmet Aerospace, Ltd. Unit C Stafford Park 7, Telford Shropshire TF3 3BQ, England, United Kingdom

Authorized Signature/date:

I, the undersigned, do hereby declare that the equipment specified above conforms to the above Directive(s) and Standard(s).

Signature:

Full Name: Nicholas Gougourtris

Position: Engineering Manager

Location: Howmet Aerospace, LLC d/b/a Howmet Fastening Systems
Kingston, New York, USA

Date: 05/10/2016 (October 05, 2020)



Declared dual number noise emission values in accordance with ISO 4871

A weighted sound power level, LWA: **85** dB (reference, pW) Uncertainty, KWA: 3 dB

A weighted emission sound pressure level at the work station, LpA: **74** dB (reference 20 µPa) Uncertainty, KpA: 3 dB

C-weighted peak emission sound pressure level, LpC, peak: **119** dB (reference 20 µPa) Uncertainty, KpC: 3 dB

Values determined according to noise test code ISO 3744. The sum of a measured noise emission value and its associated uncertainty represents an upper boundary of the range of values which is likely to occur in measurements.

Declared vibration emission values in accordance with EN 12096

Measured Vibrations emission value, a:	.20 m/s ²
Uncertainty, K:	.17 m/s ²
Values measured and determined according to ISO 28662-1, ISO 5349-2, and EN 1033	

Test data to support the above information is on file at:
Howmet Fastening Systems, Kingston Operations, Kingston, NY, USA.





Safety Instructions

GLOSSARY OF TERMS AND SYMBOLS:

 Product complies with requirements set forth by the relevant European directives.

 Read manual prior to using this equipment.

 Eye protection is required while using this equipment.

 Hearing protection is required while using this equipment.

Notes: are reminders of required procedures.

Bold, Italic type, and underline: emphasize a specific instruction.

 **WARNINGS: Must be understood to avoid severe personal injury.**

 **CAUTIONS: Show conditions that will damage equipment or structure.**

I. GENERAL SAFETY RULES:

1. A half hour long hands-on training session with qualified personnel is recommended before using Huck equipment.
2. Huck equipment must be maintained in a safe working condition at all times. Tools and hoses should be inspected at the beginning of each shift/day for damage or wear. Any repair should be done by a qualified repairman trained on Huck procedures.
3. For multiple hazards, read and understand the safety instructions before installing, operating, repairing, maintaining, changing accessories on, or working near the assembly power tool. Failure to do so can result in serious bodily injury.
4. Only qualified and trained operators should install, adjust or use the assembly power tool.
5. Do not modify this assembly power tool. This can reduce effectiveness of safety measures and increase operator risk.
6. Do not discard safety instructions; give them to the operator.
7. Do not use assembly power tool if it has been damaged.
8. Tools shall be inspected periodically to verify all ratings and markings required, and listed in the manual, are legibly marked on the tool. The employer/operator shall contact the manufacturer to obtain replacement marking labels when necessary. Refer to assembly drawing and parts list for replacement.
9. Tool is only to be used as stated in this manual. Any other use is prohibited.
10. Read MSDS Specifications before servicing the tool. MSDS specifications are available from the product manufacturer or your Huck representative.
11. Only genuine Huck parts shall be used for replacements or spares. Use of any other parts can result in tooling damage or personal injury.
12. Never remove any safety guards or pintail deflectors.
13. Never install a fastener in free air. Personal injury from fastener ejecting may occur.
14. Where applicable, always clear spent pintail out of nose

- assembly before installing the next fastener.
15. Check clearance between trigger and work piece to ensure there is no pinch point when tool is activated. Remote triggers are available for hydraulic tooling if pinch point is unavoidable.
16. Do not abuse tool by dropping or using it as a hammer. Never use hydraulic or air lines as a handle or to bend or pry the tool. Reasonable care of installation tools by operators is an important factor in maintaining tool efficiency, eliminating downtime, and preventing an accident which may cause severe personal injury.
17. Never place hands between nose assembly and work piece. Keep hands clear from front of tool.
18. Tools with ejector rods should never be cycled with out nose assembly installed.
19. When two piece lock bolts are being used always make sure the collar orientation is correct. See fastener data sheet for correct positioning.

II. PROJECTILE HAZARDS:

1. Risk of whipping compressed air hose if tool is pneudraulic or pneumatic.
2. Disconnect the assembly power tool from energy source when changing inserted tools or accessories.
3. Be aware that failure of the workpiece, accessories, or the inserted tool itself can generate high velocity projectiles.
4. Always wear impact resistant eye protection during tool operation. The grade of protection required should be assessed for each use.
5. The risk of others should also be assessed at this time.
6. Ensure that the workpiece is securely fixed.
7. Check that the means of protection from ejection of fastener or pintail is in place and operative.
8. There is possibility of forcible ejection of pintails or spent mandrels from front of tool.

III. OPERATING HAZARDS:

1. Use of tool can expose the operator's hands to hazards including: crushing, impacts, cuts, abrasions and heat. Wear suitable gloves to protect hands.
2. Operators and maintenance personnel shall be physically able to handle the bulk, weight and power of the tool.
3. Hold the tool correctly and be ready to counteract normal or sudden movements with both hands available.
4. Maintain a balanced body position and secure footing.
5. Release trigger or stop start device in case of interruption of energy supply.
6. Use only fluids and lubricants recommended by the manufacturer.
7. Avoid unsuitable postures, as it is likely for these not to allow counteracting of normal or unexpected tool movement.
8. If the assembly power tool is fixed to a suspension device, make sure that fixation is secure.
9. Beware of the risk of crushing or pinching if nose equipment is not fitted.

Continued on next page...



Safety Instructions (continued)

IV. REPETITIVE MOTION HAZARDS:

1. When using assembly power tool, the operator can experience discomfort in the hands, arms, shoulders, neck or other parts of the body.
2. When using tool, the operator should adopt a comfortable posture while maintaining a secure footing and avoid awkward or off balanced postures.
3. The operator should change posture during extended tasks to help avoid discomfort and fatigue.
4. If the operator experiences symptoms such as persistent or recurring discomfort, pain, throbbing, aching, tingling, numbness, burning sensations or stiffness, these warnings should not be ignored. The operator should tell the employer and consult a qualified health professional.

V. ACCESSORIES HAZARDS:

1. Disconnect tool from energy supply before changing inserted tool or accessory.
2. Use only sizes and types of accessories and consumables that are recommended. Do not use other types or sizes of accessories or consumables.

VI. WORKPLACE HAZARDS:

1. Be aware of slippery surfaces caused by use of the tool and of trip hazards caused by the air line or hydraulic hose.
2. Proceed with caution while in unfamiliar surroundings; there could be hidden hazards such as electricity or other utility lines.
3. The assembly power tool is not intended for use in potentially explosive environments.
4. Tool is not insulated against contact with electrical power.
5. Ensure there are no electrical cables, gas pipes, etc., which can cause a hazard if damaged by use of the tool.

VII. NOISE HAZARDS:

1. Exposure to high noise levels can cause permanent, disabling hearing loss and other problems such as tinnitus, therefore risk assessment and the implementation of proper controls is essential.
2. Appropriate controls to reduce the risk may include actions such as damping materials to prevent workpiece from 'ringing'.
3. Use hearing protection in accordance with employer's

instructions and as required by occupational health and safety regulations.

4. Operate and maintain tool as recommended in the instruction handbook to prevent an unnecessary increase in the noise level.
5. Select, maintain and replace the consumable / inserted tool as recommended to prevent an unnecessary increase in noise.
6. If the power tool has a silencer, always ensure that it is in place and in good working order when the tool is being operated.

VIII. VIBRATION HAZARDS:

1. Exposure to vibration can cause disabling damage to the nerves and blood supply to the hands and arms.
2. Wear warm clothing when working in cold conditions and keep hands warm and dry.
3. If numbness, tingling, pain or whitening of the skin in the fingers or hands, stop using the tool, tell your employer and consult a physician.

X. HYDRAULIC TOOL SAFETY INSTRUCTIONS:



WARNING: Do not exceed maximum pull or return settings on tool.

1. Carry out a daily check for damaged or worn hoses or hydraulic connections and replace if necessary.
2. Wipe all couplers clean before connecting. Failure to do so can result in damage to the quick couplers and cause overheating.
3. Ensure that couplings are clean and correctly engaged before operation.
4. Use only clean oil and filling equipment.
5. Power units require a free flow of air for cooling purposes and should therefore be positioned in a well ventilated area free from hazardous fumes.
6. Do not inspect or clean the tool while the hydraulic power source is connected. Accidental engagement of the tool can cause serious injury.
7. Be sure all hose connections are tight.
8. Wipe all couplers clean before connecting. Failure to do so can result in damage to the quick couplers and cause overheating.



Description

The 2581, 2582, and 2583 series, with appropriate nose assemblies, install a wide range of Huck blind fasteners and HUCKBOLT® fasteners. These lightweight and compact tools are particularly adapted to installing fasteners in limited clearance areas. Each tool is complete with hydraulic hoses and couplings, electric switch and cord.

An unloading valve, designed to relieve hydraulic pressure at end of the PULL stroke, is positioned by the piston. The end of the piston rod is threaded. A retaining nut and stop are included for attaching a nose assembly.

Huck Hydraulic Installation Tools are designed to be powered by Huck Powerig® Hydraulic Unit models 913H, 918, 918-5, 940, 956, or equivalent, as power sources. A specific nose assembly is required for each fastener type and size. Nose assemblies must be ordered separately. Contact your Huck representative.

The quantity of spare parts that should be kept on hand varies with the application and number of tools in service. Spare service kits containing perishable parts such as seals, back-up rings, etc., should be kept on hand at all times.

Specifications

TOOL	A	B	C
	inches (cm) NOTE: Dimensions do not include nose assembly, hoses, or cord.		
2581 A2581	7.08 (17.98)	2.14 (5.43)	8.42 (21.39)
2582 A2582	7.33 (18.62)	2.00 (5.08)	8.01 (20.34)
2583 2583-MGL-12 A2583	7.31 (18.57)	2.00 (5.08)	9.40 (23.88)

Figure 1

POWER SOURCE: Huck Powerig Hydraulic Unit

HOSE KITS: Use only genuine HUCK Hose Kits rated @ 10,000 psi working pressure.

HYDRAULIC FLUID: Hydraulic fluid shall meet DEXRON® III, DEXRON VI, MERCON, Allison C-4 or equivalent ATF specifications. Fire resistant fluid may be used if it is an ester based fluid such as Quintolubric HFD or equivalent. Water based fluid shall NOT be used as serious damage to equipment will occur.

MAX INLET TEMP: 125°F (51.7°C)

MAX FLOW RATE: 2 gpm (7.5 l/m)

MAX PULL PRESSURE: 8400 psi (580 bar)

MAX RETURN PRESSURE: 3200 psi (220 bar)

PULL CAPACITY:

2581 family: 8,240 lbf (36.6 kN) @ 5700 psi (393 bar)
10,700 lbf (47.6 kN) @ 7400 psi (510 bar)
12,200 lbf (54.3 kN) @ 8400 psi (580 bar)

2582/2583 family:
10,850 lbf (48.3 kN) @ 8400 psi (580 bar)

2583-MGL-12:
7,000 lbf (31.1 kN) @ 5400 psi (372 bar)
10,360 lbf (46.1 kN) @ 8000 psi (552 bar)

STROKE:

2581 family: .937 inches (2.38 cm)
2582 family: .750 inches (1.91 cm)
2583 family: 1.50 inches (3.81 cm)
2583-MGL-12: 1.50 inches (3.81 cm)

Note: Stroke may be adjusted by installing Stroke Limiters as shown in Figures X. Stroke Limiter Kits for 2583-MGL-12 are listed in OPTIONAL EQUIPMENT.

WEIGHT:

2581 family: appx. 5.5 lbs (2.49 kg)
2582 family: appx. 4.1 lbs (1.86 kg)
2583 family: appx. 4.6 lbs (2.09 kg)

Where the following trade names are used in this manual, please note:

DEXRON is a registered trademark of General Motors Corporation.
Loctite is a registered trademark of Henkel Corporation, U.S.A.
LUBRIPLATE is a registered trademark of Fiske Brothers Refining Co.
MERCON is a registered trademark of Ford Motor Corp.
MOLYKOTE is a registered trademark of Dow Corning Corporation
Never-Seez is a registered trademark of Bostik, Inc.
Quintolubric is a registered trademark of Quaker Chemical Corp.
Slic-tite is a registered trademark of LA-CO Industries, Inc.
Spirolox is a registered trademark of Smalley Steel Ring Company
Teflon is a registered trademark of E. I. du Pont de Nemours and Company.
Threadmate is a registered trademark of Parker Intangibles LLC.
TRUARC is a trademark of TRUARC Co. LLC.
Vibra-Tite is a registered trademark of ND Industries, Inc. USA.



Principle of Operation

A trigger controls the PULL and RETURN strokes. When the trigger is pressed, hydraulic pressure is directed to PULL side of the piston, and fastener installation begins. At the end of PULL stroke, before the trigger is released, piston uncovers flats of unloading valve, thus unloading pressure by allowing fluid to flow back to Powerig® Hydraulic Unit. When the trigger is released at end of PULL stroke when fastener is installed, the pressure is directed to RETURN side of the piston and moves piston forward. Nose assembly, with tool, is then pushed off fastener.

Tool Set-up

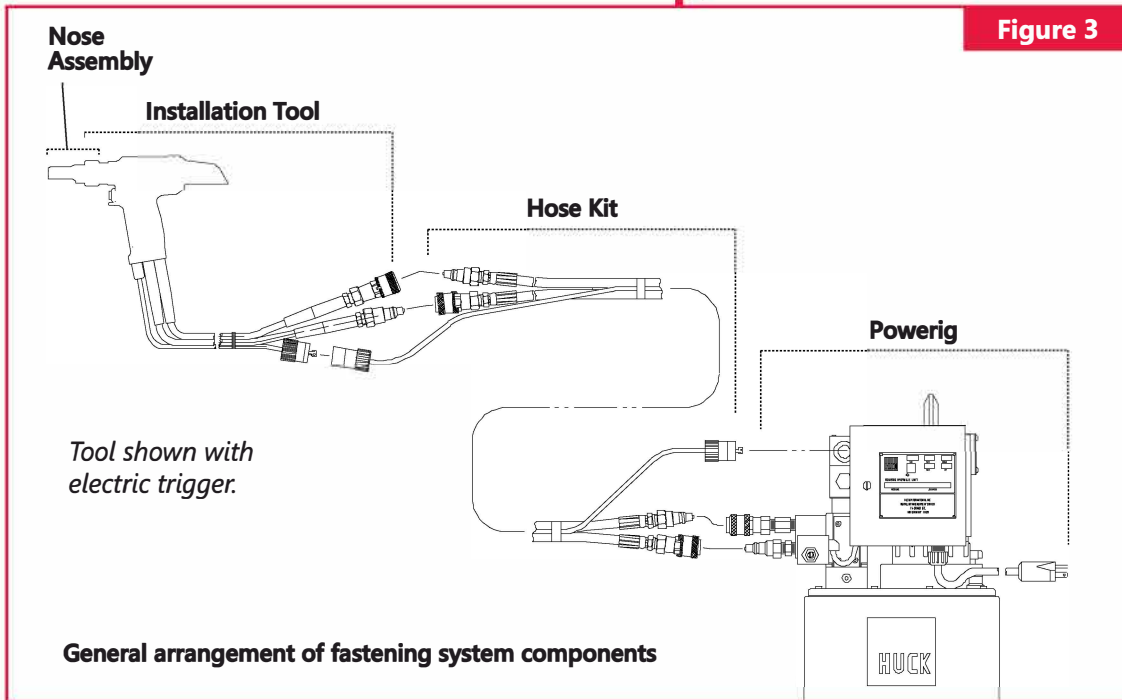

WARNING: Note tool danger zones in Figure 2.

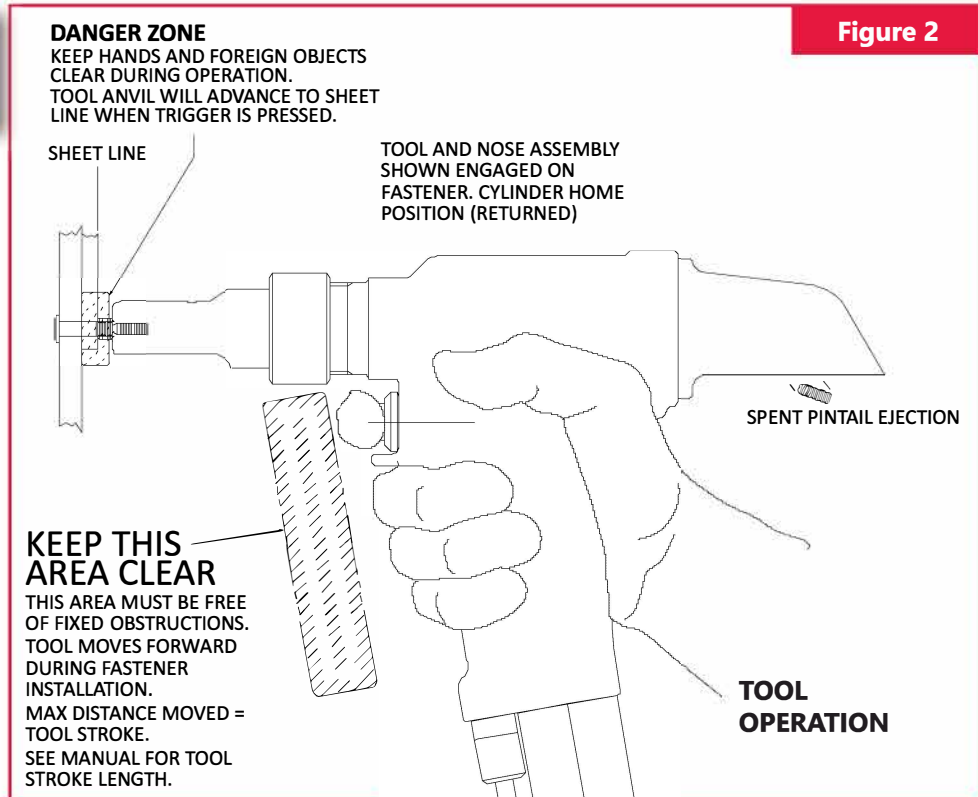



Optional Equipment

To maintain CE conformity, only CE compatible equipment should be used with these tools. Installation tools and nose assemblies are the only CE components unless otherwise noted. Controls and other hardware shown in the manual are for domestic use only.

TEFLON® Stick	-	503237			
TEFLON® Sealant	-	620012			
Loctite® 243	-	508567			
Never-Seez® NS-160 <i>(anti-seize and lubricating compound)</i>	-	505565			
LUBRIPLATE® 130-AA	-	502723			
Threadmate™ (4oz. tube)	-	508517			
Pressure Gage	-	T-124833CE			
Service Parts Kits <i>(Includes all perishable seals, O-rings, and Back-up rings. A spare Service Parts Kit should be kept on hand at all times.)</i>			Tool	Kit No.	
			-2581/A2581	2581KIT	
			-2582/A2582	2582KIT	
			-2583/A2583	2583KIT	
Piston Assembly Tool Kit	-	123110-1			
<i>Piston Assembly Tool</i>	-	<i>123111-1</i>			
<i>Spacer</i>	-	<i>123112-1</i>			
<i>Polyseal Insertion Tool</i>	-	<i>121694-2580</i>			
Polyseal Insertion Tool	-	505940	(2582, 2583)		
2583-MGL-12 Stroke Limiters			STROKE LENGTH	Kit No.	
<i>limits stroke to .875 inches</i>			.875 in (2.2 cm)	120753	
<i>limits stroke to .750 inches</i>			.750 in (1.9 cm)	130803	
<i>limits stroke to .562 inches</i>			.562 in (1.4 cm)	130804	
					Control Cord Assembly
					<i>(Contains trimmed cord with plug)</i>
					CORD LENGTH
					PART No.
				-	2.5 ft 131484-9
				-	3.5 ft 131484-3
				-	13.3 ft 131484-1
				-	17.75 ft 131484-11
				-	26 ft 131484-4
				-	30.75 ft 131484-10
				-	39 ft 131484-8
					Hose and Cord Kits
					<i>(Contains control cord assembly and both hydraulic hoses with male and female quick connect fittings at each end)</i>
					HOSE LENGTH
					PART No.
				-	6 ft HAY06-EAA00
				-	12 ft HAY12-EAA00
				-	26 ft HAY26-EAA00
				-	38 ft HAY38-EAA00
				-	52 ft HAY52-EAA00
					Individual Hoses
					<i>(As shown in Figure 12 and Figure 13, these hoses do not have quick connect fittings at each end)</i>
					HOSE LENGTH
					PART No.
				-	2 ft HPHX02-AA10
				-	6 ft HPHX06-AA10
				-	12 ft HPHX12-AA10
				-	17 ft HPHX17-AA10
				-	25 ft HPHX25-AA10
				-	30 ft HPHX30-AA10
				-	38 ft HPHX38-AA10

Sticker Locations

HUCK hydraulic tools come labeled with stickers which contain safety and pressure settings information. Stickers must remain on the tool and readable. If a sticker becomes damaged or worn, or if it has been removed from the tool, or when replacing Cylinder, it must be ordered and placed in the location shown.

(A)

**590517
HUCK/Year of
Manufacture
Sticker**



(B)

**590424
CE and WARNING
Sticker**

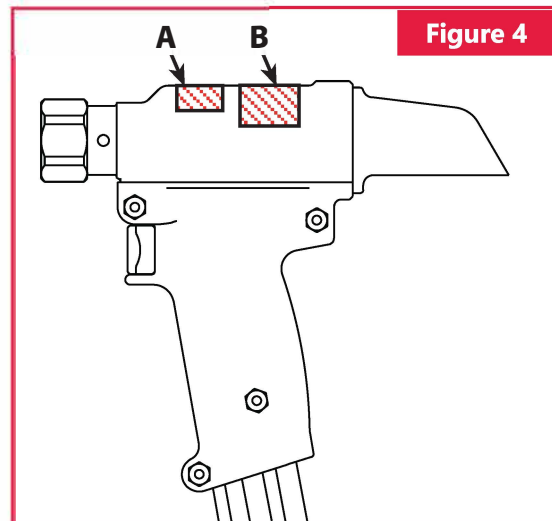



Preparation for Use

Read all **WARNINGS** and **CAUTIONS** before operating or performing maintenance on **HUCK** equipment.



WARNINGS:

Read full manual before using tool.

A half-hour training session with qualified personnel is recommended before using Huck equipment.

When operating Huck installation equipment, always wear approved eye and ear protection.

Be sure there is adequate clearance for the operator's hands before proceeding.



CAUTION: Do not let disconnected hoses and couplers contact a dirty floor. Keep harmful material out of hydraulic fluid. Dirt in hydraulic fluid causes valve failure in Tool and In Powerig Hydraulic Unit.



WARNING: Huck recommends that only Huck Powerig Hydraulic Units be used as a power source for Huck installation equipment. Hydraulic power units that deliver high pressure for both PULL and RETURN, AND ARE NOT EQUIPPED WITH RELIEF VALVES ARE SPECIFICALLY NOT RECOMMENDED AND MAY BE DANGEROUS.



CAUTIONS:

Do not abuse the tool by dropping it, using it as a hammer, or otherwise causing unnecessary wear and tear.

Reasonable care of installation tools by operators is an important factor in maintaining tool efficiency and reducing down time.



WARNING: Correct PULL and RETURN pressures are required for operator's safety and for Installation Tool's function. Pressure Gauge T-124833CE is available for checking pressures. See Tool SPECIFICATIONS and Gauge Instruction Manual. Failure to verify pressures may result in severe personal injury.



WARNING: Be sure to connect Tool's hydraulic hoses to Powerig Hydraulic Unit before connecting Tool's switch control cord to unit. If not connected in this order and disconnected in the reverse order, severe personal injury may occur.

CONNECTING THE TOOL

Remove shipping caps from ends of pipe plug fittings. Coat pipe plug threads, hose fitting threads, and quick connect fittings with Threadmate™, which is available from Huck in a 4oz. tube as part number 508517.



CAUTION: Do not use TEFLON® tape on pipe threads. Pipe threads may cause tape to shred resulting in tool malfunction.

1. Use Huck Powerig® Hydraulic Unit, or equivalent, that has been prepared for operation per instruction manual. Check both PULL and RETURN pressures and, if required, adjust to pressures given in **SPECIFICATIONS** section of this manual. See both hydraulic unit and T-124833CE instruction manuals before/during checking procedure. Visually inspect for leaks and to verify that End Cap is installed correctly.
2. First, turn hydraulic unit to OFF. Then disconnect power supply from hydraulic unit. Disconnect trigger control system from hydraulic unit.
3. Connect tool hoses to hydraulic unit. If required, adjust position of trigger assembly on return pressure hose. Connect trigger control system to hydraulic unit.
4. Connect hydraulic unit to power supply (air or electric). Turn hydraulic unit to ON. Hold Tool trigger depressed for 30 seconds; depress trigger a few times to cycle tool and to circulate hydraulic fluid — observe action of Tool and check for leaks.
5. Select nose assembly for fastener to be installed. Disconnect hydraulic unit from power supply; disconnect Tool's trigger control system from hydraulic unit. Attach nose assembly to tool.
6. Reconnect Tool trigger control system to hydraulic unit; reconnect unit to power supply. Check operation of nose assembly. Install fasteners in test plate of correct thickness with proper size holes, and inspect installed fasteners. If fasteners do not pass inspection, see **TROUBLESHOOTING** to identify and correct the malfunction.
7. Operator should receive training on proper use from qualified personnel.

Note: Where a part number (P/N) is given, Huck sells that part.



Operating Instructions

FOR SAFE OPERATION, THIS SECTION MUST BE READ AND UNDERSTOOD.

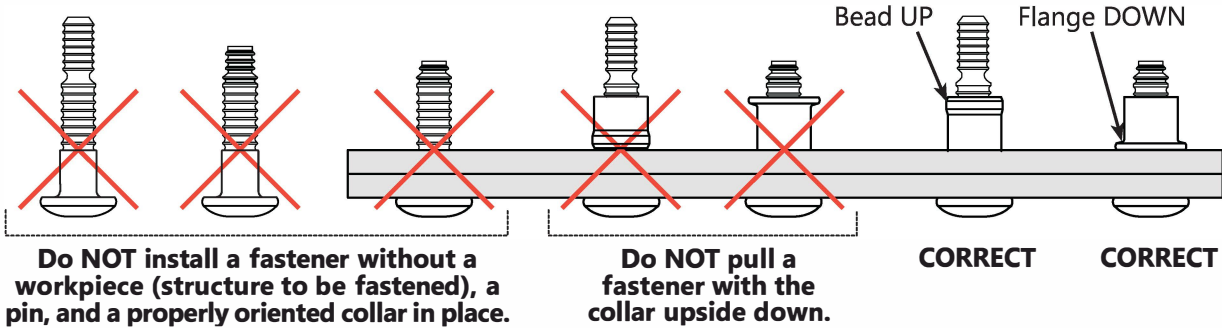

Do NOT install a fastener without a workpiece (structure to be fastened), a pin, and a properly oriented collar in place.

Do NOT pull a fastener with the collar upside down.

CORRECT

CORRECT



WARNINGS:

To avoid severe personal injury, wear approved eye and ear protection. Be sure of adequate clearance for operator's hands before proceeding with fastener installation.

If the tool comes with a pintail deflector or bottle, make sure it is attached to the tool and directed away from all personnel.

Do NOT attempt to install a pin without placing the fastener and collar in the work piece (structure to be fastened).

Do NOT attempt to install a pin without a properly oriented collar in place. The collar flange must be against work piece.

If these safety measures are not followed, the fastener could eject with great velocity and cause severe personal injury.

This condition can cause pin to eject with great velocity and force if the pintail breaks off or teeth/grooves strip. This may cause severe personal injury.

To avoid pinch point, never place hand between nose assembly and work piece.

Only use compatible equipment with this tool.



CAUTIONS: Remove excess gap from between the sheets. This permits enough pintail to emerge from collar for ALL jaw teeth to engage with pintail. If ALL teeth do not engage properly, jaws will be damaged.

Note: In certain situations, it may be permissible to use a BobTail tool and fastener without a collar to remove sheet gap prior to full installation with a collar. Consult qualified Huck engineering personnel before attempting this operation.

HUCKBOLT® FASTENER INSTALLATION:

Place pin in workpiece and place collar over pin. See WARNING. (If Collar has only one tapered end, that end MUST be out toward tool - not next to workpiece.) Hold pin and push nose assembly onto pin protruding through collar until nose anvil touches collar. Depress trigger and hold until collar is swaged and pintail breaks. Release trigger. Tool will go into RETURN stroke. Tool and nose are ready for next installation cycle.

BLIND FASTENER INSTALLATION:

Fastener may be placed in workpiece or in end of nose assembly. See WARNING. In either case, tool/nose must be held against work and at right angles to it. Depress and hold trigger until fastener is installed and pintail breaks. Release trigger. Tool will go into its return stroke. Tool/nose are ready for next installation cycle.

Hydraulic Fittings

FIGURE 5



Use a fine India stone to remove any nicks or burrs from these areas to prevent damage to O-ring of Female



Maintenance

GOOD SERVICE PRACTICES

The efficiency and life of your installation tool depends upon proper maintenance and good service practices. Using this manual will help give you a clear understanding of your tool and basic maintenance procedures. Please read this entire page before proceeding with maintenance/repair.

Individual parts must be handled carefully and examined for damage or wear. Replace parts where required. Always replace O-rings and back-up rings when the tool is disassembled for any reason.

Use proper hand tools in a clean well lit area for maintenance and/or repair. Always be careful to keep dirt and debris out of pneumatic and hydraulic systems. Only standard hand tools are required in most cases. Where a special tool is required, the description and part number are given.

While clamping installation tool and/or parts in a vise, and when parts require force, use suitable soft materials to cushion impact. For example, using a half-inch brass drift, wood block and/or vise with soft jaws greatly diminishes the possibility of a damaged tool. Remove components in a straight line without bending, cocking or undue force, and reassemble tool with the same care.

Consult TROUBLESHOOTING section of this manual if a malfunction occurs. Where a part number (P/N) is given, HUCK sells that part.

FLUID MAINTENANCE

For fluid maintenance please refer to NAS 1638 class 9 or ISO CODE 18/15 or SAE level 6

STANDARD SEALANTS AND LUBRICANTS



CAUTION: Do not use TEFLON® tape on pipe threads. Pipe threads may cause tape to shred resulting in tool malfunction.

Coat hose fitting threads with a non-hardening TEFLON® thread compound such as Threadmate™, which is available from HUCK in a 4oz. tube as part number 508517.

Smear LUBRIPLATE 130AA, or equivalent lubricant, on O-rings and mating surfaces this prevents nicking/ pinching O-rings on any rough/tight spot and increases ease of assembly. (LUBRIPLATE 130AA is available from HUCK in a tube as part number 502723.)

SERVICE PARTS KIT

Service parts kits contain perishable parts for your specific tool. For convenience and as experience indicates, keep extra kits (O-rings, back-up rings, and other standard items) and tool parts on hand. For additional information/specifications on O-rings and back-up rings, see notes and specifications for standard parts. Inspect tool daily. Check hoses, fittings and disconnects for leaks or damage.

PREVENTIVE MAINTENANCE

System Inspection

Operating efficiency of the tool is directly related to performance of the complete system, including tool and nose assembly, hydraulic hoses, control trigger assembly and the Powerig® Hydraulic Unit. Therefore, an effective preventive maintenance program includes scheduled inspections of the system to detect and correct minor troubles.

1. Inspect tool for external damage.
2. Verify that hoses and fittings, and trigger connections are secure.
3. Inspect hydraulic hoses for signs of damage. Replace if required.
4. Inspect tool, hoses, and Powerig Hydraulic Unit during operation to detect abnormal heating, leaks or vibration.

POWERIG HYDRAULIC UNIT MAINTENANCE

Maintenance and repair instructions are in applicable Powerig Hydraulic Unit Instruction Manual.

TOOL AND NOSE ASSEMBLY MAINTENANCE AND PRECAUTIONS

Whenever disassembled, and also at regular intervals (depending on severity and length of use), replace all O-rings and back-up rings. Spare Parts Kits should be kept on hand. Inspect cylinder bore, piston and rod/ extension, and unloading valve for scored surfaces, excessive wear or damage, and replace parts as necessary. On any assembly with UNITIZED™ Jaws, clean all parts in mineral spirits or isopropyl alcohol only. Under no circumstances should jaws come in contact with other solvents. Also, do not let jaws soak; dry the jaws immediately after cleaning. Dry other parts before assembling. Urethane soaks up other solvents, then swells up and becomes unusable. Use a sharp pointed "pick" to remove embedded particles from the pull grooves of the jaws.



Disassembly

The following procedure is for complete disassembly. Disassemble only subassemblies necessary to check and replace damaged seals, wipers, back-up rings and components. **Always replace seals, wiper, O-rings and back-up rings of disassembled subassemblies.**



WARNING: Be sure to disconnect tool control trigger system from Powerig® Hydraulic Unit before disconnecting tool hydraulic hoses from unit. If not disconnected in this order before any maintenance or cleaning is done, severe personal injury may occur.

1. Read **WARNING** Disconnect tool's electrical connector from hydraulic unit. Uncouple tool's hydraulic hoses and drain into a container.
2. Remove tool retaining nut using 1-3/8 open end wrench. Slide nose assembly anvil away from tool. Unscrew collet from tool piston.
3. Unscrew four screws from handle assembly. Remove screws and nuts. Separate handle halves. (Figure 6)
4. (Optional) Unscrew hydraulic hoses from tool. **NOTE:**

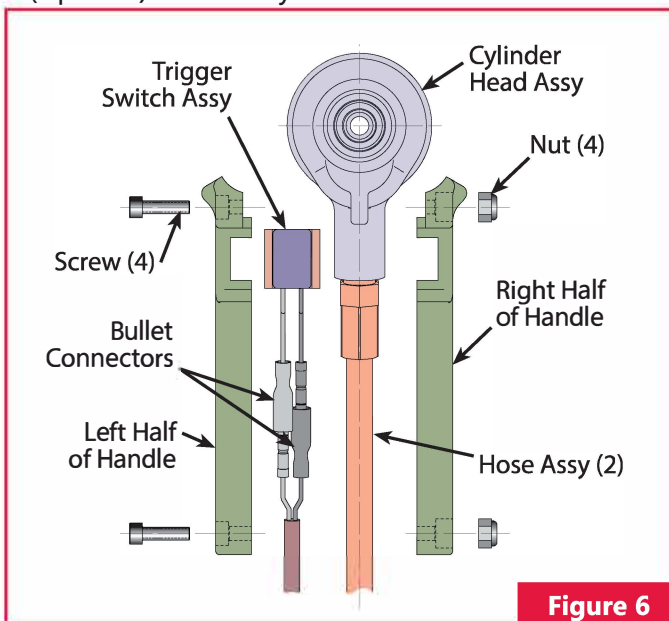

Figure 6

Do not remove hydraulic hoses from tool unless replacing them.

5. Remove quick disconnects from hoses, and push rearward on piston until remaining hydraulic fluid is drained into container, and discard fluid.
6. **2581, 2582, 2583:** Lift trigger switch assembly from handle half. Pull control cord out of built-in handle strain relief. Pull both bullet connectors apart. (Figures 6 & 9)

A2581, A2582, A2583: Lift air trigger assembly from handle half. Pull air hose out of handle's built-in strain relief. (Figure 10)

DISASSEMBLE CYLINDER ASSEMBLY

7. Remove deflector from end cap. Remove socket head screw from end cap (barbed retainer of 2581/A2581).
8. Hold a spanner wrench in slots of retaining ring (barbed retainer of 2581/A2581). Loosen and remove retainer.
9. Push piston, with unloading valve, and end cap/rear gland out of tool. (For 2581 & A2581, use optional piston assembly bullet) See (Figure 7)

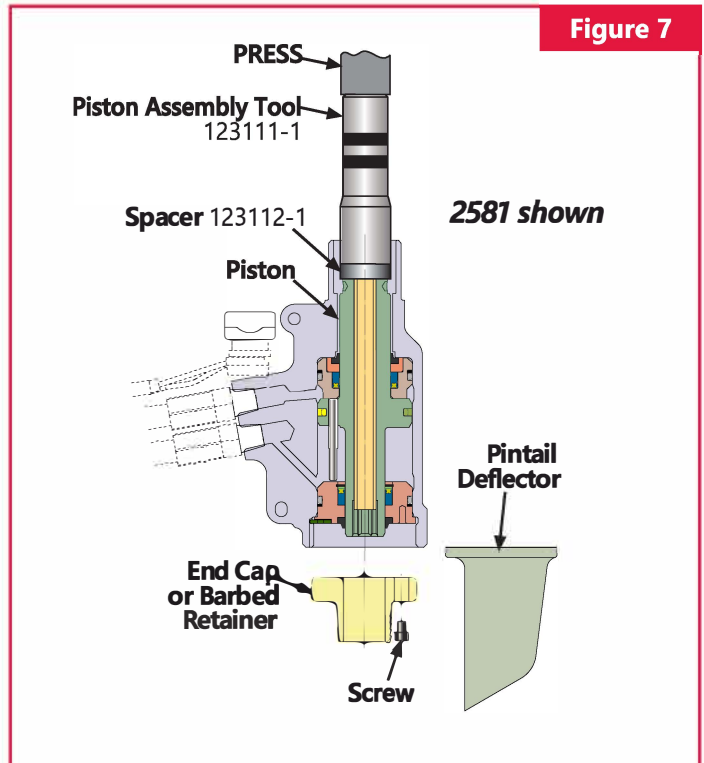

Figure 7

10. Slide end cap and unloading valve from piston.
11. Use a small diameter pointed rod to remove all seals, wipers, O-rings and back-up rings from components.

SERVICING TRIGGER SWITCH ASSEMBLY

2581, 2582, 2583:

Remove switch. Loosen set screw and carefully pry switch out with a small screw driver. Disconnect bullet connectors from cord. Pull cord out. (Figures 6 and 12)

SERVICING AIR TRIGGER ASSEMBLY

A2581, A2582, A2583:

Unscrew air trigger assembly. Loosen air fitting. Pull out air trigger hose. Loosen air quick disconnect and remove it. (Figure 13)



Assembly

Refer to appropriate illustrations and **MAINTENANCE**. Clean components with mineral spirits or similar solvent. Inspect for wear/damage and replace as necessary. Replace all seals of disassembled components. Use seals from Service Parts Kit. Smear LUBRIPLATE 130AA or Parker Super-O-Lube on O-rings, Back-up Rings, and mating parts to ease assembly. Assemble tool taking care not to damage seals..

2581, A2581 PREP:

1. Screw GLYD ring assembly tool on back of cylinder to prevent damage to GLYD ring when inserting piston and gland assembly. Install GLYD ring assembly on piston as follows: Place the special O-ring in groove. Roll GLYD ring's diameter to a diameter smaller than piston before placing glyd ring on top of O-ring. Coat GLYD ring with suitable lubricant to insure that ring stays in place during piston installation. (Figure 8)

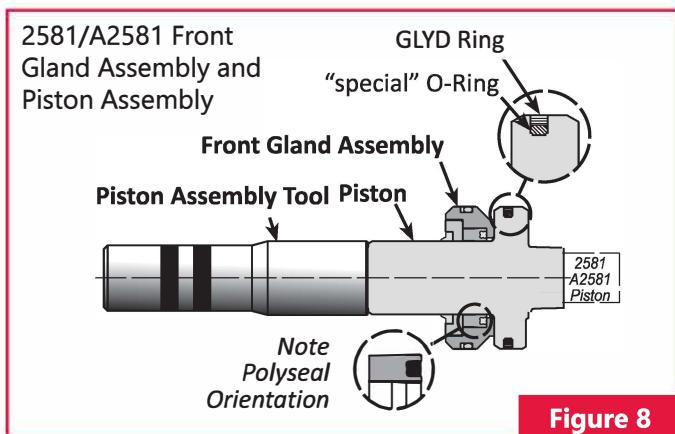

2. Taking care not to pinch inner ring, press polyseal into front gland housing, and install O-ring and back-up ring on front gland assembly. **NOTE: To keep polyseal in front gland, push front wiper housing into front gland. Hold housing against polyseal while pressing front gland/polyseal onto piston.**

2582, 2583, A2582, A2583 PREP:

1. Install wiper and polyseal into front cylinder grooves as shown in figures 10 and 11.
2. Install O-ring and back-up rings on piston.

ALL MODELS:

3. Install stroke limiter, if used, on rear of piston.
4. Screw piston assembly tool and spacer on front of piston.

5. Install stop and thread retaining nut onto cylinder to act as a stand-off.
6. Carefully drive, or press, piston assembly into cylinder.
7. Remove retaining nut and stop, and piston assembly tool (and GLYD ring insertion tool for 2581 family).
8. Install unloading valve into piston with four flats toward REAR of tool.
9. **2581, A2581:** Install following in rear gland: O-ring and back-up ring, polyseal, spacer, and retaining ring; as shown in Figure 9. Install wiper in rear gland. Align recess in rear gland with groove in cylinder, and press assembled gland into cylinder. Install locking disc.

2582, A2582, 2583, A2583: Install O-ring, back-up ring, and polyseal on end cap as shown in Figure 10 or 11, and press assembled end cap into cylinder.

10. Screw barbed retainer/retaining ring into cylinder until it bottoms out, then back it out to first visible threaded hole in rear gland/barbed retainer. Install and tighten locking screw.
11. If hydraulic hoses have been removed, thread hoses into cylinder.
12. **2581, 2582, 2583:** Assemble electrical cord to connector. Attach cord to trigger switch. Place switch into handle. Press cord down through handle half built-in strain relief.

A2581, A2582, A2583: Place air trigger assembly into handle's trigger fitting, and press down through handle half built-in strain relief.

13. Assemble handle halves and fasten with screws and nuts as shown in Figure 6.
14. **2581, A2581:** Before attaching nose assembly and using tool, read entire **PREPARATION FOR USE** section. Hold 3/8" hex wrench in back of tool when tightening collet. Use pintail tube if necessary.
15. See WARNING in DISASSEMBLY and reverse the given procedure i.e. Connect hoses first, and then connect electrical control cord.



2581 & A2581 Head and Handle Assembly

Figure 9

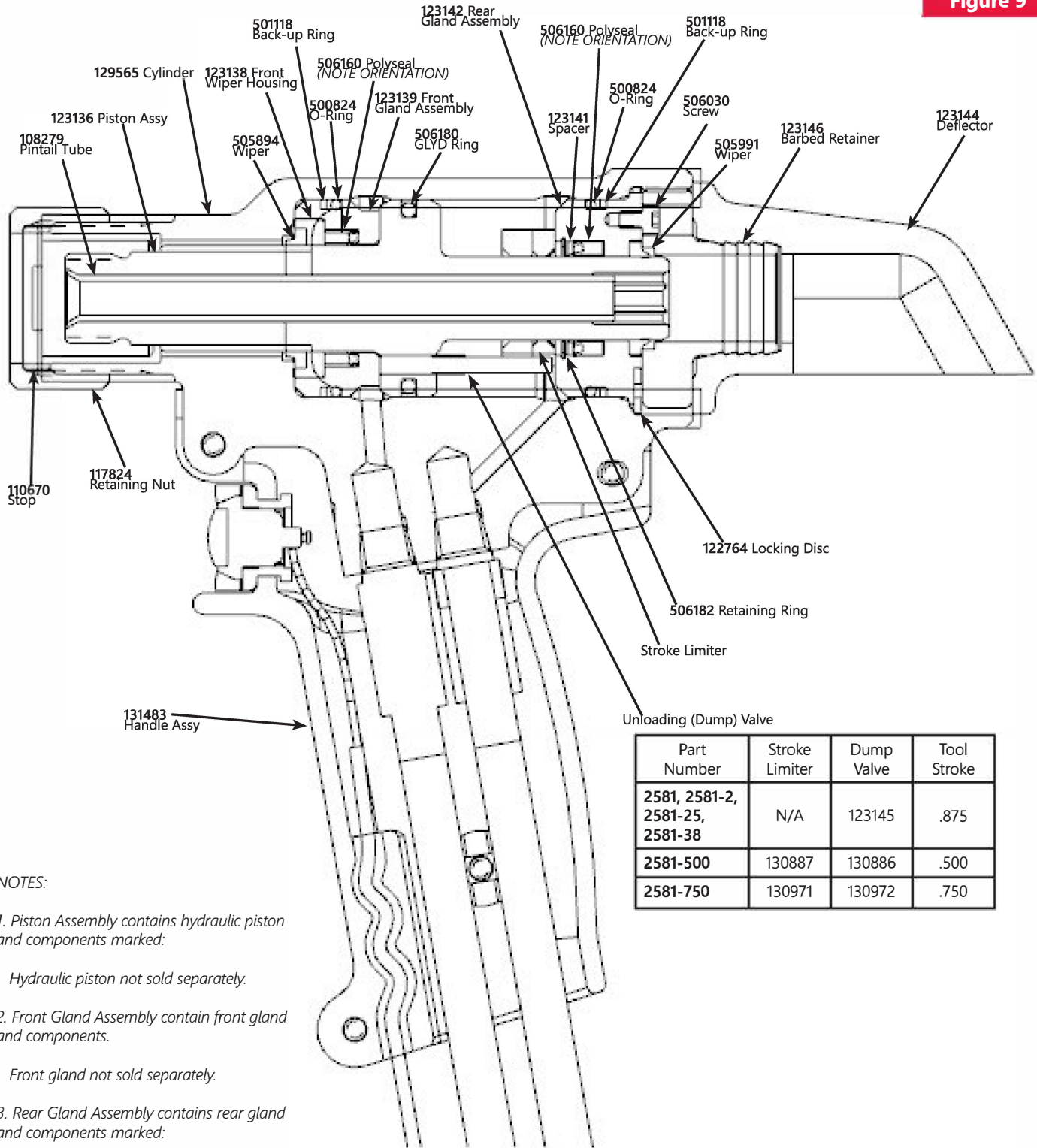

NOTES:

1. Piston Assembly contains hydraulic piston and components marked:

Hydraulic piston not sold separately.

2. Front Gland Assembly contain front gland and components.

Front gland not sold separately.

3. Rear Gland Assembly contains rear gland and components marked:

Rear gland not sold separately.

See Figure 12 for 2581 Trigger, Hoses, and Cord part numbers.
See Figure 13 for A2581 Trigger and Hoses Part numbers.

Part Number	Stroke Limiter	Dump Valve	Tool Stroke
2581, 2581-2, 2581-25, 2581-38	N/A	123145	.875
2581-500	130887	130886	.500
2581-750	130971	130972	.750



2582 & A2582 Head and Handle Assembly

Figure 10

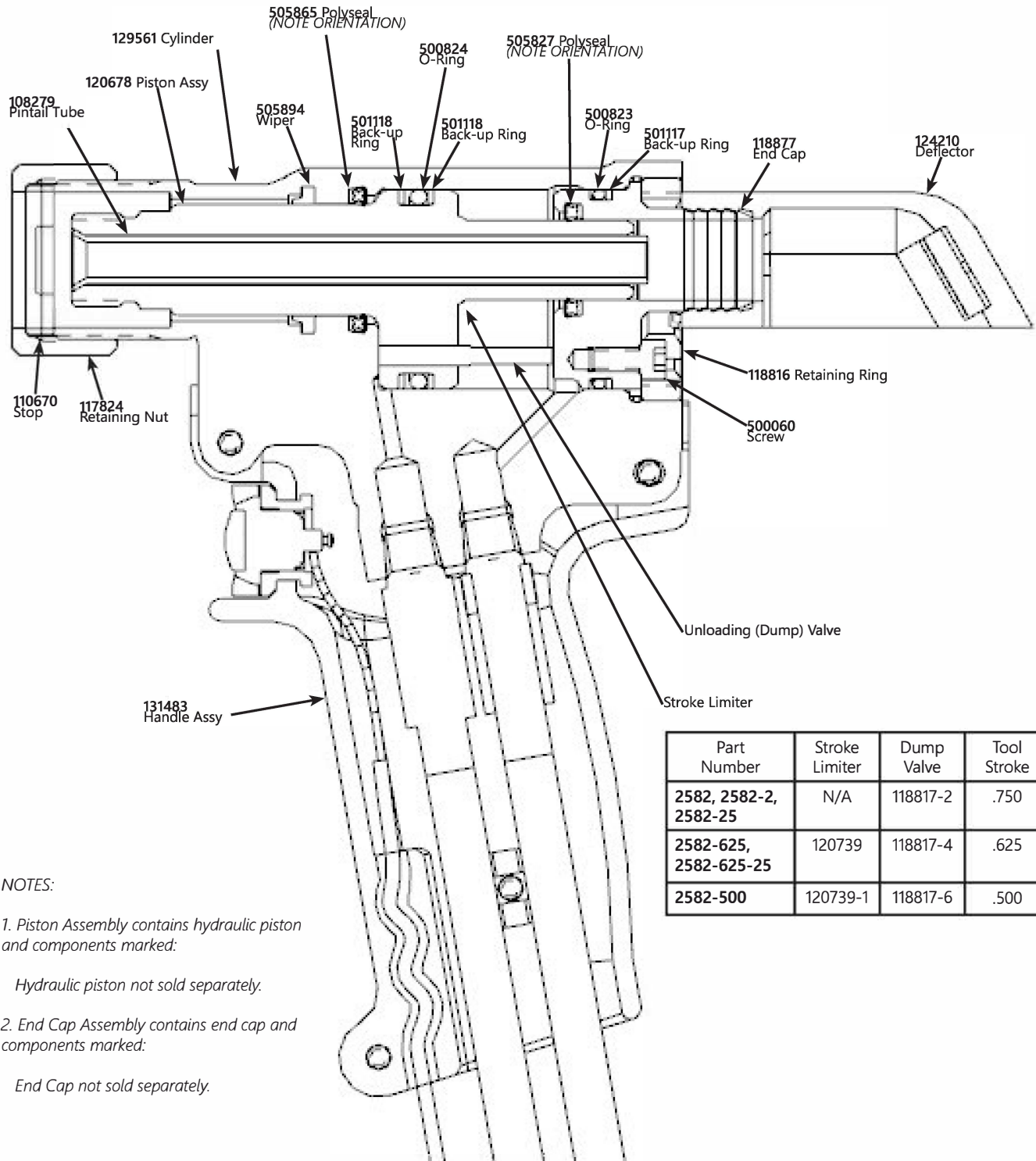

Part Number	Stroke Limiter	Dump Valve	Tool Stroke
2582, 2582-2, 2582-25	N/A	118817-2	.750
2582-625, 2582-625-25	120739	118817-4	.625
2582-500	120739-1	118817-6	.500

NOTES:

1. Piston Assembly contains hydraulic piston and components marked:

Hydraulic piston not sold separately.

2. End Cap Assembly contains end cap and components marked:

End Cap not sold separately.

See Figure 12 for 2582 Trigger, Hoses, and Cord part numbers.
See Figure 13 for A2582 Trigger and Hoses Part numbers.



2583 & A2583 Head and Handle Assembly

Figure 11

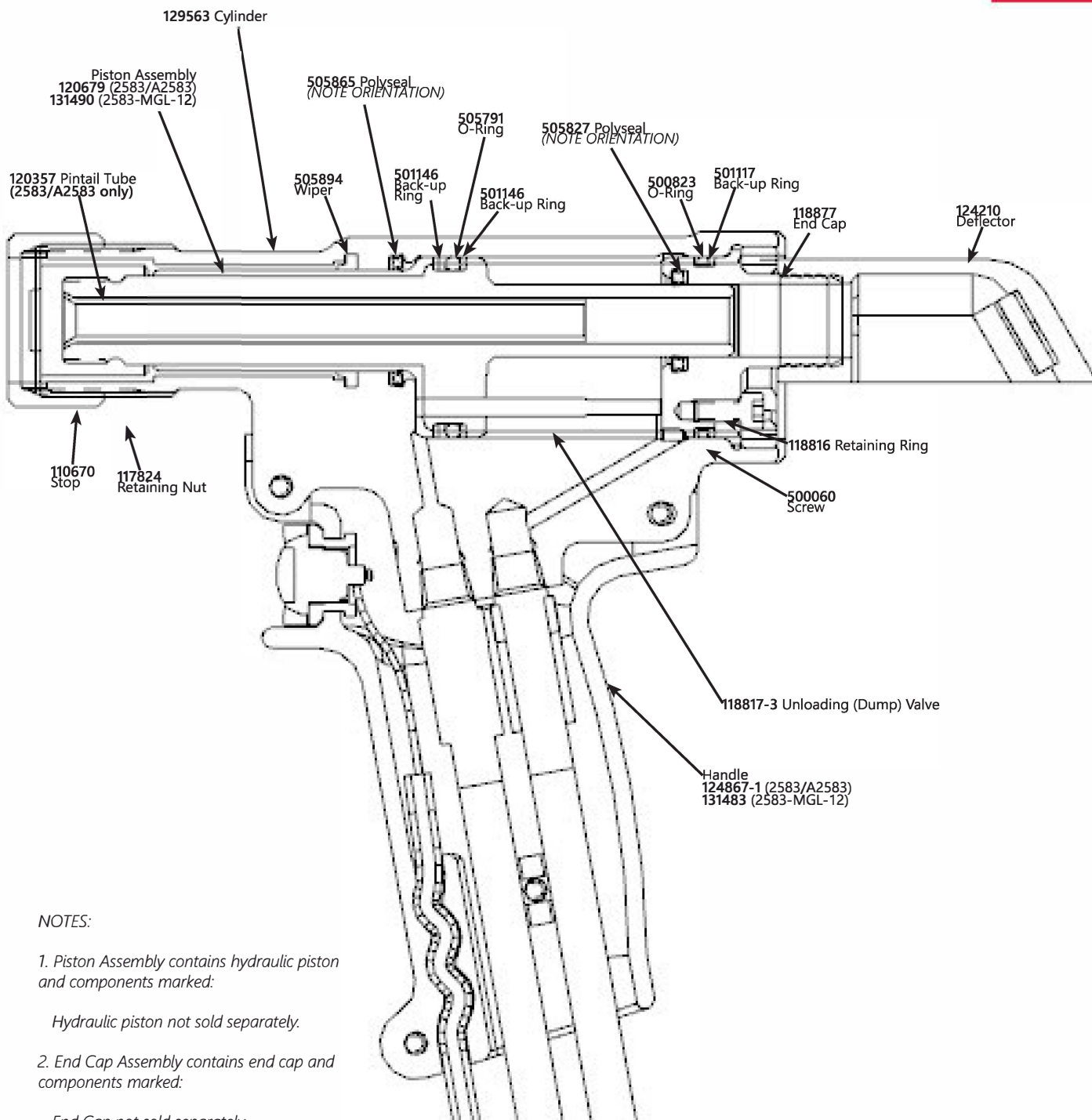

NOTES:

1. Piston Assembly contains hydraulic piston and components marked:

Hydraulic piston not sold separately.

2. End Cap Assembly contains end cap and components marked:

End Cap not sold separately.

See Figure 12 for 2583 Trigger, Hoses, and Cord part numbers.
See Figure 13 for A2583 Trigger and Hoses Part numbers.



2581, 2582, 2583 Trigger, Hoses, and Cord

Figure 12

See Figure 09 for 2581 and A2581 Head Assembly part numbers.
 See Figure 10 for 2582 and A2582 Head Assembly part numbers.
 See Figure 11 for 2583 and A2583 Head Assembly part numbers.

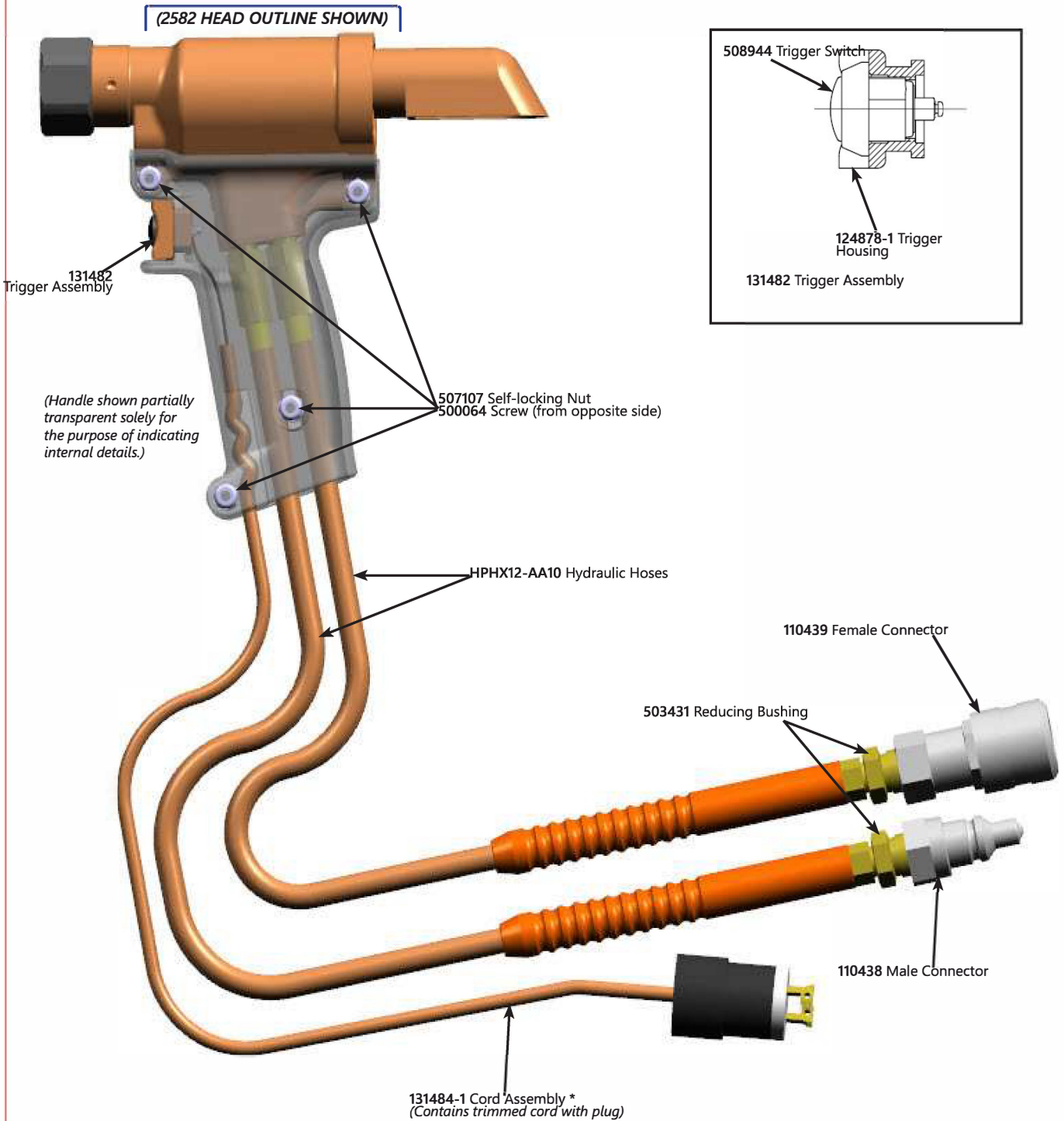



A2581, A2582, A2583 Trigger and Hoses

Figure 13

See Figure 09 for 2581 and A2581 Head Assembly part numbers.
 See Figure 10 for 2582 and A2582 Head Assembly part numbers.
 See Figure 11 for 2583 and A2583 Head Assembly part numbers.

(2582 HEAD OUTLINE SHOWN)

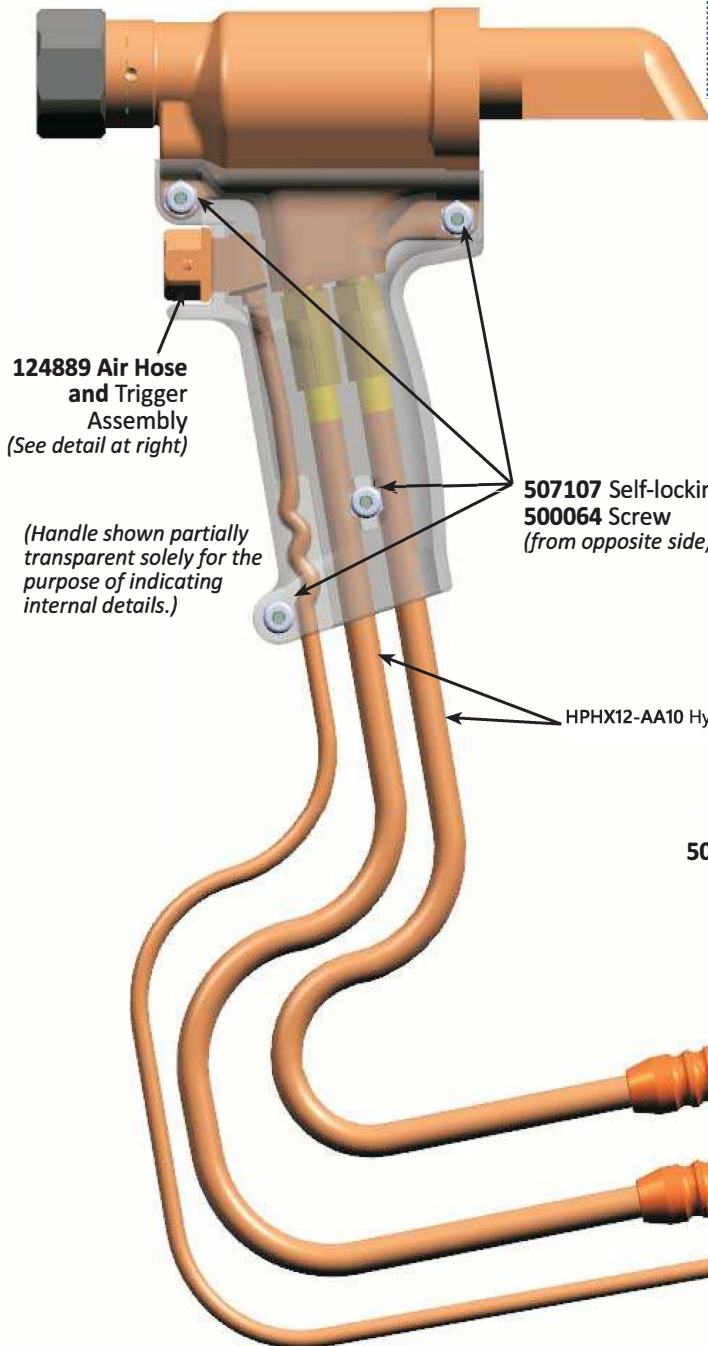

(Handle shown partially transparent solely for the purpose of indicating internal details.)

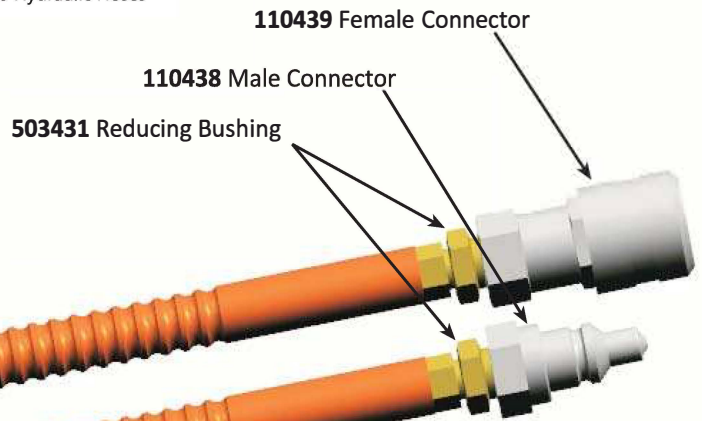
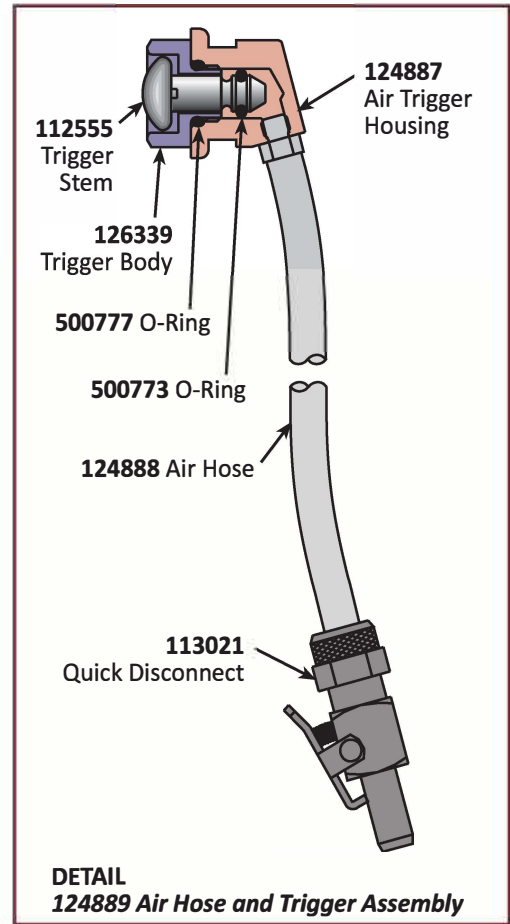

* Tools are shipped standard with 12 ft. hoses. For other lengths available, see OPTIONAL EQUIPMENT.



Troubleshooting

Always check the simplest possible cause of a malfunction first. For example, a loose or disconnected trigger line. Then proceed logically, eliminating each possible cause until the defective part is located. Where possible, substitute known good parts for suspected defective parts. Use Trouble Shooting Chart as an aid for locating and correcting trouble.

- 1. Tool fails to operate when trigger is depressed.**
 - a. Inoperative Powerig® Hydraulic Unit. See applicable instruction manual.
 - b. Loose air or electric connections.
 - c. Damaged trigger assembly.
 - d. Loose or faulty hydraulic hose couplings.
 - e. Unloading valve not installed in Tool.
- 2. Tool operates in reverse.**
 - a. Reversed hydraulic hose connections between hydraulic unit and Tool.
- 3. Tool leaks hydraulic fluid.**
 - a. Defective Tool O-rings or loose hose connections at Tool.
- 4. Hydraulic couplers leak fluid.**
 - a. Damaged or worn O-rings in coupler body. See Coupler 110440.
- 5. Hydraulic fluid overheats.**
 - a. Hydraulic unit not operating properly.
 - b. Unloading valve installed incorrectly.
 - c. Powerig Hydraulic Unit running in reverse (918: 918-5) See unit's manual.
- 6. Tool operates erratically and fails to install fastener properly.**
 - a. Low or erratic hydraulic pressure; air in system
 - b. Damaged or worn piston/anvil O-ring in Tool.
 - c. Unloading valve installed incorrectly.
 - d. Excessive wear on sliding surfaces of Tool parts.
 - e. Excessive wear of unloading valve in Tool.
- 7. Pull grooves on fastener pintail stripped during PULL stroke.**
 - a. Operator not sliding anvil completely onto fastener pintail.
 - b. Incorrect fastener grip.
 - c. Worn or damaged jaw segments.
 - d. Metal particles in pull grooves of jaw segments.
 - e. Excessive sheet gap.
- 8. Collar of HUCKBOLT® fastener not completely swaged.**
 - a. Improper Tool operation. See Trouble 6.
 - b. Scored anvil.
- 9. Jaw segments do not maintain proper position in collet.**
 - a. Improper operation of follower. Check number of follower O-Rings
- 10. Tool "hangs-up" on swaged collar of HUCKBOLT Fastener.**
 - a. Improper Tool operation. See Trouble 6.
 - b. RETURN pressure too low.
- 11. Pintail of fastener fails to break.**
 - a. Improper Tool operation. See Trouble 6.
 - b. Pull grooves on fastener stripped. See Trouble 7.
 - c. PULL pressure too low.
 - d. Worn unloading valve.
- 12. Shear collar on Huck blind fastener not driven.**
 - a. Improper Tool operation.
 - b. Worn or damaged driving anvil in nose assembly.



Limited Warranties

Limited Lifetime Warranty on BobTail® Tools:

Huck International, Inc. warrants to the original purchaser that its BobTail® installation tools manufactured after 12/1/2016 shall be free from defects in materials and workmanship for its **useful lifetime**. This warranty does not cover special order / non-standard products, or part failure due to normal wear, tool abuse or misapplication, or user non-compliance with the service requirements and conditions detailed in the product literature.

Two Year Limited Warranty on Installation Tools:

Huck International, Inc. warrants that its installation tools and Powerig® hydraulic power sources manufactured after December 1, 2016 shall be free from defects in materials and workmanship for a period of two years from date of purchase by the end user. This warranty does not cover special order / non-standard products, or part failure due to normal wear, tool abuse or misapplication, or user non-compliance with the service requirements and conditions detailed in the product literature.

90 Day Limited Warranty on Nose Assemblies and Accessories:

Huck International, Inc. warrants that its nose assemblies and accessories shall be free from defects in materials and workmanship for a period of 90 days from date of purchase by the end user. This warranty does not cover special clearance noses, or special order / non-standard product, or part failure due to normal wear, abuse or misapplication, or user non-compliance with the service requirements and conditions detailed in the product literature.

Useful lifetime is defined as the period over which the product is expected to last physically, up to the point when replacement is required due to either normal in-service wear, or as part of a complete overhaul. Determination is made on a case-by case basis upon return of parts to Huck International, Inc. for evaluation.

Tooling, Part(s) and Other Items not manufactured by Huck:

HUCK makes no warranty with respect to the tooling, part(s), or other items manufactured by third parties. HUCK expressly disclaims any warranty expressed or implied, as to the condition, design, operation, merchantability, or fitness for use of any tool, part(s), or other items thereof not manufactured by HUCK. HUCK shall not be liable for any loss or damage, directly or indirectly, arising from the use of such tooling, part(s), or other items or breach of warranty or for any claim for incidental or consequential damages.

Huck shall not be liable for any loss or damage resulting from delays or non-fulfillment of orders owing to strikes, fires, accidents, transportation companies or for any reason or reasons beyond the control of the Huck or its suppliers.

Huck Installation Equipment:

Huck International, Inc. reserves the right to make changes in specifications and design and to discontinue models without notice.

Huck Installation Equipment should be serviced by trained service technicians only.

Always give the serial number of the equipment when corresponding or ordering service parts.

Complete repair facilities are maintained by Huck International, Inc. Please contact one of the offices listed below.

Eastern

One Corporate Drive Kingston, New York 12401-0250
Telephone (845) 331-7300 FAX (845) 334-7333

Outside USA and Canada

Contact your nearest Huck International location (see reverse).

In addition to the above repair facilities, there are Authorized Tool Service Centers (ATSC's) located throughout the United States. These service centers offer repair services, spare parts, Service Parts Kits, Service Tool Kits and Nose Assemblies. Please contact your Huck Representative or the nearest Huck International location (see reverse) for the ATSC in your area.

Applifast.



251 Cree Crescent, Winnipeg, MB Canada R3J 3X4
Tel: 204 837 8361 • 1 800 563 1293
info@applifast.com



applifast.com