



# TRANSPARENT ANTIBAC DISPENSERS

THE EASY CHOICE YOU CAN TRUST



## WHAT MAKES THE TRANSPARENT ANTIBAC DISPENSERS **UNIQUE?**

**A unique, fully transparent 1 litre manual and 1.2 litre touch free closed, sealed cartridge dispenser that meets Health Canada requirement.**

Using hygienically sealed cartridges, the Transparent Antibac dispenser dispenses registered products with a clear view of the required Drug Facts Table.



**Easy to secure** with lockable covers preventing contamination or theft.



**Easy to install** in any space. Wall mounted using adhesive pads or screws.



**Health Canada Compliant**  
Easy to read Drug Facts Table at point of care.



**Easy to replenish** cartridges in seconds, saving on both time and cost.



**Hygienically sealed cartridge** to prevent product contamination as compared to refillable dispensers.



**Easy to use** with large, intuitive buttons on our manual dispensers.



**Easy to maintain** with no mess, no dripping or clogging of pumps.



**Cost savings** allows users to clearly see soap levels without having to open the cover, cutting down on maintenance time and cost.

THE MAIN **BENEFITS...**



**ULTIMATE PRODUCT LEVEL VISIBILITY**

The Transparent Antibac Dispenser allows the user to quickly and easily identify information within the drug facts table, making it compliant with Health Canada regulations.

The Transparent Antibac Dispenser brings ultimate product level visibility for easy maintenance. The transparent design enables the fill level to be instantly and accurately visible from any angle. This reassures users that product is inside the dispenser; and helps staff know when cartridges need changing without opening the dispenser, to save time and cut maintenance costs.



**ROBUST, RELIABLE & WARRANTED FOR LIFE**



SCJ Professional touch-free dispensers are warranted for five years, and SCJ Professional manual dispensers are warranted for their lifetime, to be free from defects in materials and workmanship under normal use or the original purchasing end customer may be eligible to receive a free replacement dispenser or part(s). Warranty is only available in Canada. Warranty applies only to dispensers installed in the end customer's facility that are exclusively using SC Johnson Professional products. Warranty does not cover dispensers purchased from unauthorized distributors. End customers must register the dispensers. Other terms and conditions apply and eligibility is subject to verification. For the full terms and conditions visit [warranty.scjp.com](http://warranty.scjp.com). Warranty provided by SC Johnson Professional CA Inc. ("SCJP"), 1 Webster Street, Brantford, ON N3T 5R1.

THIS WARRANTY IS IN LIEU OF ALL OTHER WARRANTIES, EXPRESS OR IMPLIED, INCLUDING ANY WARRANTY OF MERCHANTABILITY OR FITNESS FOR A PARTICULAR PURPOSE. Our liability shall not exceed the actual amount paid for the dispenser. We shall not be liable for any consequential, incidental, special, or punitive damages.

End customers are deemed to have accepted the above warranty and limitation of liability. They cannot be changed verbally or in writing, except in a written agreement signed by SCJP.

**Transparent Antibac Dispenser 1L**

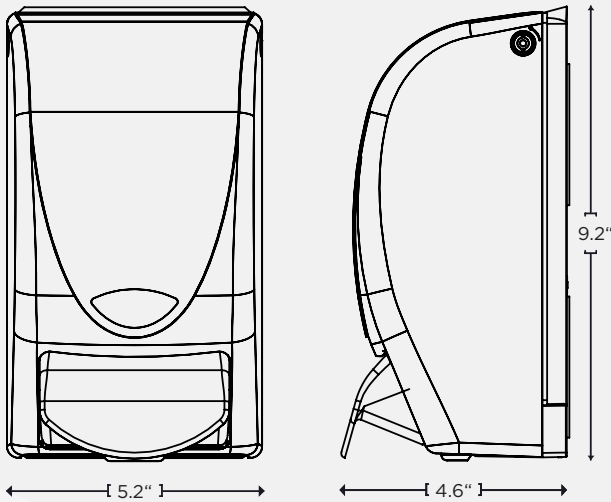

**Transparent Antibac Dispenser 1.2L Touch-Free**

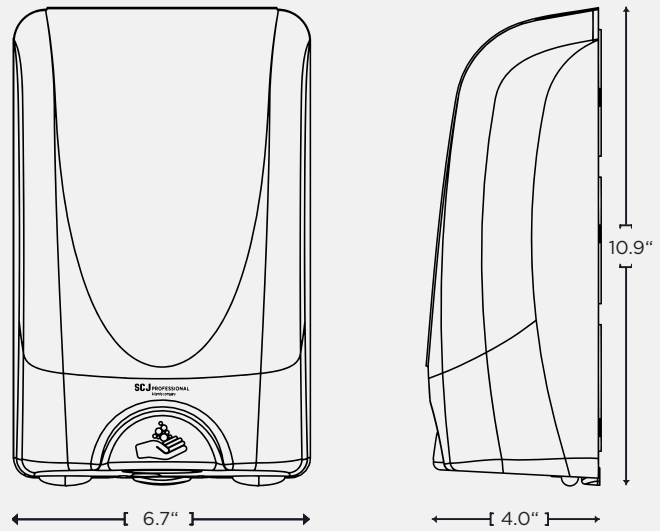

STOCK CODE	DISPENSER	SIZE	CASE QTY	DIMENSIONS
ANTILDSCA	Transparent Antibac Dispenser 1L	1 Litre	15	5.2"W x 4.6"D x 9.2"H
TF2ANT	Transparent Antibac Dispenser 1.2L Touch-Free	1.2 Litre	8	6.7"W x 4.0"D x 10.9"H

CA LIT1570/1121

This information and all further technical advice is based upon our present knowledge and experience. However, it implies no liability or other legal responsibility on our part, including with regard to existing third party intellectual property rights, especially patent rights. In particular, no warranty, whether express or implied, or guarantee of product properties in the legal sense is intended or implied. We reserve the right to make any changes according to technological progress or further developments.



# Applifast.



251 Cree Crescent, Winnipeg, MB Canada R3J 3X4  
Tel: 204 837 8361 • 1 800 563 1293  
info@applifast.com



[applifast.com](http://applifast.com)