



Instruction Manual

3585 series

Hydraulic Installation Tool

3585



3585PT



Table of Contents

Declaration of Conformity	2
Safety Instructions	4-5
Tool Description	6
Specifications	6
Principle of Operation	7
Preparation for Use	8
Operating Instructions	9
Maintenance	10
Sticker Locations	10
Disassembly Procedure	11
Assembly Procedure	12
Tool Components & Drawings	13-14
Kits and Accessories	15
Troubleshooting	15



**HOWMET
AEROSPACE**

Declaration of Conformity

Manufacturer:

Huck International, LLC, Industrial Products Group, 1 Corporate Drive, Kingston, NY, 12401, USA

Description of Machinery:

Model 3585 hydraulic installation tool and specials based on their design (e.g. PR#####).

Relevant provisions complied with:

Council Directive related to Machinery (2006/42/EC)

Supply of Machinery (Safety) Regulations 2008

British Standard related to hand held, non-electric power tools (ISO 11148-1:2011)

Representatives:

UK: Paul Carson, Huck International, Ltd. Unit C Stafford Park 7, Telford Shropshire TF3 3BQ, England, United Kingdom

EU: Lutz Baumann, Hildesheim Operations, Fairchild Fasteners Europe - VSD GmbH, Steven 3, 31135, Hildesheim, Germany

Authorized Signature/date:

I, the undersigned, do hereby declare that the equipment specified above conforms to the above Directive(s) and Standard(s).

Signature: _____

Full Name: Nicholas Gougouris

Position: Engineering Manager

Location: Huck International, LLC d/b/a Howmet Fastening Systems
Kingston, New York, USA

Date: 11/22/2021 (November, 22, 2021)



Declared dual number noise emission values in accordance with ISO 4871

A weighted sound power level, LWA: **89** dB (reference 1 pW) Uncertainty, KWA: 3 dB

A weighted emission sound pressure level at the work station, LpA: **78** dB (reference 20 µPa) Uncertainty, KpA: 3 dB

C-weighted peak emission sound pressure level, LpC, peak: **119** dB (reference 20 µPa) Uncertainty, KpC: 3 dB

Values determined according to noise test code ISO 3744. The sum of a measured noise emission value and its associated uncertainty represents an upper boundary of the range of values which is likely to occur in measurements.

Declared vibration emission values in accordance with EN 12096

Measured Vibrations emission value, a:	.40 m/s ²
Uncertainty, K:	.02 m/s ²
Values measured and determined according to ISO 28662-1, ISO 5349-2, and EN 1033	

Test data to support the above information is on file at:
Howmet Fastening Systems, Kingston Operations, Kingston, NY, USA.



DANGER - IMPORTANT

DO NOT EXCEED MINIMUM BEND RADIUS

Failure to follow all pertinent hydraulic tool safety requirements are to be followed. ***Failure to heed the warnings below could lead to a damaged hose, tool, personal injury, or death.***

- This high pressure hose is not to be used other than assembled in a genuine HUCK tool or hose assembly or used as a replacement for the hose of a genuine HUCK tool or hose assembly.
- Improper use of this product can cause ***property damage, personal injury, and death***, including but not limited to electrocution, fluid injection or loss of limb caused by high pressure leak, dangerously whipping hose or contact with suddenly moving or falling objects.
- Do not exceed rated working pressure (***700 bar/10150 psi***) or minimum bend radius (see chart below). Do not use in temperatures less than ***-40°C (-40°F)*** or greater than ***+100°C (+212°F)***. Do not exceed fluid working temperature of ***+70°C (+158°F)***.
- Do not use if the hose is kinked, abraded, cut, bulged, or leaking. Do not attempt to repair the hose.
- Refer to a HUCK hydraulic tool manual for hose inspection and maintenance intervals.
- Store hose assemblies in a clean dry area.

Hose Type	Minimum Bend Radius	
124881 Series	2.17 Inches	55 mm
126107 Series	2.76 Inches	70 mm
HPH Series	1.97 Inches	50 mm



Safety Instructions

GLOSSARY OF TERMS AND SYMBOLS:



-Product complies with requirements set forth by the relevant UK and European directives.



-Read manual prior to using this equipment.



-Eye protection is required while using this equipment.



-Hearing protection is required while using this equipment.

Notes: are reminders of required procedures.

Bold, Italic type, and underline: emphasize a specific instruction.



WARNINGS: Must be understood to avoid severe personal injury.



CAUTIONS: Show conditions that will damage equipment or structure.

I. GENERAL SAFETY RULES:

1. A half hour long hands-on training session with qualified personnel is recommended before using Huck equipment.
2. Huck equipment must be maintained in a safe working condition at all times. Tools and hoses should be inspected at the beginning of each shift/day for damage or wear. Any repair should be done by a qualified repairman trained on Huck procedures.
3. For multiple hazards, read and understand the safety instructions before installing, operating, repairing, maintaining, changing accessories on, or working near the assembly power tool. Failure to do so can result in serious bodily injury.
4. Only qualified and trained operators should install, adjust or use the assembly power tool.
5. Do not modify this assembly power tool. This can reduce effectiveness of safety measures and increase operator risk.
6. Do not discard safety instructions; give them to the operator.
7. Do not use assembly power tool if it has been damaged.
8. Tools shall be inspected periodically to verify all ratings and markings required, and listed in the manual, are legibly marked on the tool. The employer/operator shall contact the manufacturer to obtain replacement marking labels when necessary. Refer to assembly drawing and parts list for replacement.
9. Tool is only to be used as stated in this manual. Any other use is prohibited.
10. Read MSDS Specifications before servicing the tool. MSDS specifications are available from the product manufacturer or your Huck representative.
11. Only genuine Huck parts shall be used for replacements or spares. Use of any other parts can result in tooling damage or personal injury.
12. Never remove any safety guards or pintail deflectors.
13. Never install a fastener in free air. Personal injury from fastener ejecting may occur.
14. Where applicable, always clear spent pintail out of nose

assembly before installing the next fastener.

15. Check clearance between trigger and work piece to ensure there is no pinch point when tool is activated. Remote triggers are available for hydraulic tooling if pinch point is unavoidable.
16. Do not abuse tool by dropping or using it as a hammer. Never use hydraulic or air lines as a handle or to bend or pry the tool. Reasonable care of installation tools by operators is an important factor in maintaining tool efficiency, eliminating downtime, and preventing an accident which may cause severe personal injury.
17. Never place hands between nose assembly and work piece. Keep hands clear from front of tool.
18. Tools with ejector rods should never be cycled with out nose assembly installed.
19. When two piece lock bolts are being used always make sure the collar orientation is correct. See fastener data sheet for correct positioning.

II. PROJECTILE HAZARDS:

1. Risk of whipping compressed air hose if tool is pneudraulic or pneumatic.
2. Disconnect the assembly power tool from energy source when changing inserted tools or accessories.
3. Be aware that failure of the workpiece, accessories, or the inserted tool itself can generate high velocity projectiles.
4. Always wear impact resistant eye protection during tool operation. The grade of protection required should be assessed for each use.
5. The risk of others should also be assessed at this time.
6. Ensure that the workpiece is securely fixed.
7. Check that the means of protection from ejection of fastener or pintail is in place and operative.
8. There is possibility of forcible ejection of pintails or spent mandrels from front of tool.

III. OPERATING HAZARDS:

1. Use of tool can expose the operator's hands to hazards including: crushing, impacts, cuts, abrasions and heat. Wear suitable gloves to protect hands.
2. Operators and maintenance personnel shall be physically able to handle the bulk, weight and power of the tool.
3. Hold the tool correctly and be ready to counteract normal or sudden movements with both hands available.
4. Maintain a balanced body position and secure footing.
5. Release trigger or stop start device in case of interruption of energy supply.
6. Use only fluids and lubricants recommended by the manufacturer.
7. Avoid unsuitable postures, as it is likely for these not to allow counteracting of normal or unexpected tool movement.
8. If the assembly power tool is fixed to a suspension device, make sure that fixation is secure.
9. Beware of the risk of crushing or pinching if nose equipment is not fitted.

Continued on next page...



Safety Instructions (continued)

IV. REPETITIVE MOTION HAZARDS:

1. When using assembly power tool, the operator can experience discomfort in the hands, arms, shoulders, neck or other parts of the body.
2. When using tool, the operator should adopt a comfortable posture while maintaining a secure footing and avoid awkward or off balanced postures.
3. The operator should change posture during extended tasks to help avoid discomfort and fatigue.
4. If the operator experiences symptoms such as persistent or recurring discomfort, pain, throbbing, aching, tingling, numbness, burning sensations or stiffness, these warnings should not be ignored. The operator should tell the employer and consult a qualified health professional.

V. ACCESSORIES HAZARDS:

1. Disconnect tool from energy supply before changing inserted tool or accessory.
2. Use only sizes and types of accessories and consumables that are recommended. Do not use other types or sizes of accessories or consumables.

VI. WORKPLACE HAZARDS:

1. Be aware of slippery surfaces caused by use of the tool and of trip hazards caused by the air line or hydraulic hose.
2. Proceed with caution while in unfamiliar surroundings; there could be hidden hazards such as electricity or other utility lines.
3. The assembly power tool is not intended for use in potentially explosive environments.
4. Tool is not insulated against contact with electrical power.
5. Ensure there are no electrical cables, gas pipes, etc., which can cause a hazard if damaged by use of the tool.

VII. NOISE HAZARDS:

1. Exposure to high noise levels can cause permanent, disabling hearing loss and other problems such as tinnitus, therefore risk assessment and the implementation of proper controls is essential.
2. Appropriate controls to reduce the risk may include actions such as damping materials to prevent workpiece from 'ringing'.
3. Use hearing protection in accordance with employer's

instructions and as required by occupational health and safety regulations.

4. Operate and maintain tool as recommended in the instruction handbook to prevent an unnecessary increase in the noise level.
5. Select, maintain and replace the consumable / inserted tool as recommended to prevent an unnecessary increase in noise.
6. If the power tool has a silencer, always ensure that it is in place and in good working order when the tool is being operated.

VIII. VIBRATION HAZARDS:

1. Exposure to vibration can cause disabling damage to the nerves and blood supply to the hands and arms.
2. Wear warm clothing when working in cold conditions and keep hands warm and dry.
3. If numbness, tingling, pain or whitening of the skin in the fingers or hands, stop using the tool, tell your employer and consult a physician.
4. Support the weight of the tool in a stand, tensioner or balancer in order to have a lighter grip on the tool.

X. HYDRAULIC TOOL SAFETY INSTRUCTIONS:



WARNINGS:

Do not exceed maximum pull or return settings on tool.

Be sure all hose connections are tight. All tool hoses must be connected.

1. Carry out a daily check for damaged or worn hoses or hydraulic connections and replace if necessary.
2. Wipe all couplers clean before connecting. Failure to do so can result in damage to the quick couplers and cause overheating.
3. Ensure that couplings are clean and correctly engaged before operation.
4. Use only clean oil and filling equipment.
5. Power units require a free flow of air for cooling purposes and should therefore be positioned in a well ventilated area free from hazardous fumes.
6. Do not inspect or clean the tool while the hydraulic power source is connected. Accidental engagement of the tool can cause serious injury.
7. Be sure all hose connections are tight.
8. Wipe all couplers clean before connecting. Failure to do so can result in damage to the quick couplers and cause overheating.

3585 series Hydraulic Installation Tool (HK1080)



Description

The 3585 series Hydraulic Installation Tools are cylinder and piston assemblies; complete with handle, hoses, couplers, and a control cord, and are ready to be attached to, and powered by, a HUCK Powerig® Hydraulic Unit (model 918 or equivalent); nose assemblies are available separately. These tools install a variety of fasteners.

The tools have a dump valve, positioned by the piston, which relieves the hydraulic pressure at both ends (PULL and RETURN) of the stroke. Correct PULL and RETURN pressures are important for operation of the tool and nose assembly, and for the safety of the operator. Use HUCK Set-up Gauge (P/N T-124833CE) to check and set pressures. The gauge is available separately and includes instructions for use.

MODEL 3585

Installs **-16 (1/2")** to **-24 (3/4")** Pintail-style Lockbolt Fasteners

Has a pintail ejector to eject broken pintails from the nose assembly

Has a nose adapter and retaining rings for attaching nose assemblies

MODEL 3585PT

Installs **-16 (1/2")** to **-24 (3/4")** Huck-Spin, Huck-Spin2®, and Bob-Tail® Fasteners

Does NOT have a pintail ejector (it installs fasteners without a pintail break)

Has a pass-through hole (on the piston) to allow the included T-wrench to install Huck-Spin collars

Specifications

POWER SOURCE: HUCK Powerig® hydraulic power source

HOSE KITS: Use only genuine HUCK Hose Kits rated @ 10,000 psi (689.5 BAR) working pressure.

3585 SERIES DIMENSIONS:

(not including hose, cord, or nose assembly)

	Inches	Centimeters
Length	7.84	19.9
Width	4.02	10.2
Height	10.4	26.4

MAX OPERATING TEMP: 125°F (51.7°C)

MAX FLOW RATE: 2 gpm (7.5 l/m)

MAX PULL PRESSURE: 7400 psi (510 BAR)

MAX RETURN PRESSURE: 2200 psi (152 BAR)

PULL CAPACITY: 45,668 lbs @ 7400 psi
(203 kN @ 510 BAR)

STROKE:

3585: 1.81 inches (4.60 cm)

3585PT: 1.90 inches (4.83 cm)

WEIGHT: 19 lbs (8.62 kg)

HYDRAULIC FLUID:

Hydraulic fluid shall meet DEXRON® III, DEXRON VI, MERCON®, Allison C4-approved, or equivalent Automatic Transmission Fluid (ATF) specifications. Fire-resistant fluid may be used if it is an ester-based fluid such as Quintolubric® HFD or equivalent. Water-based fluid shall NOT be used as serious damage to equipment will occur.

Where the following trade names are used in this manual, please note:

DEXRON is a registered trademark of General Motors Corporation.

GLYD Ring is a registered trademark of Trelleborg Sealing Solutions Germany GmbH

Loctite is a registered trademark of Henkel IP & Holding GmbH

LUBRIPLATE is a registered trademark of Fiske Brothers Refining Co.

MERCON is a registered trademark of Ford Motor Corp.

MOLYKOTE is a registered trademark of Dow Corning Corporation

Never-Seez is a registered trademark of Bostik, Inc.

Quintolubric is a registered trademark of Quaker Chemical Corp.

Slic-tite is a registered trademark of LA-CO Industries, Inc.

Spirolox is a registered trademark of Smalley Steel Ring Company

Teflon is a registered trademark of Chemours Company FC.

Threadmate is a registered trademark of Parker Intangibles LLC.

TRUARC is a trademark of TRUARC Co. LLC.

Vibra-Tite is a registered trademark of ND Industries, Inc. USA.



Principle of Operation

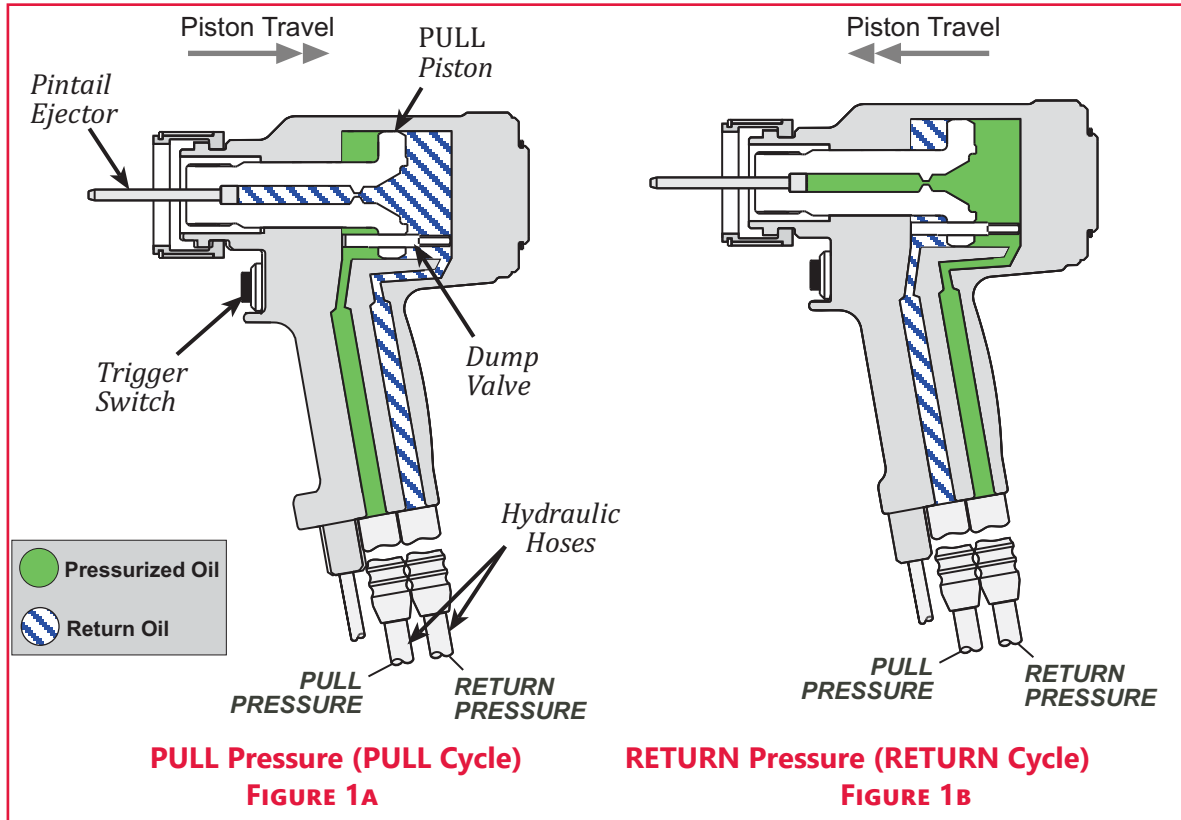

PULL CYCLE

Figure 1A: When the trigger is pressed, a solenoid-operated valve in the Powerig® hydraulic power source directs pressurized fluid through the PULL hose to the front side of the piston, and allows fluid on the RETURN side to flow back to the tank. The piston and nose assembly collet move rearward installing the fastener.

When the piston reaches the end of the PULL stroke, it uncovers flats at the rear of the dump valve. These flats provide a passage for hydraulic fluid from the PULL side to the RETURN side of the piston, unloading (or “dumping”) the pressurized fluid back to the tank.

RETURN CYCLE

Figure 1B: When the trigger is released, the solenoid is de-energized and the valve directs pressurized fluid to the rear of the piston, and the fluid on the PULL side flows back to the tank. This causes the piston and collet to move forward, and pushes the nose assembly and tool off the swaged (installed) fastener.

When the piston reaches the end of the RETURN stroke, pressure builds, causing the Powerig to shut off, completing the cycle.



Preparation for Use



WARNINGS:

Read entire manual before using tool.

Before using HUCK equipment, a 30-minute training session with qualified personnel is recommended.

When operating HUCK equipment, always wear approved eye and hearing protection.

Ensure adequate clearance for operator's hands before proceeding.

Only HUCK Powerig® Hydraulic Units should be used to power HUCK tools. Hydraulic units that deliver high PULL and RETURN pressures *must be equipped with relief valves; units not equipped with relief valves are not recommended and MAY BE DANGEROUS.*

Set PULL and RETURN pressures as specified in **SPECIFICATIONS**. Failure to properly set pressures may result in serious personal injury. Use Pressure Gauge T-124833CE as indicated in its instruction manual.

Connect tool hoses to the Powerig *before* connecting tool switch-control cord to the Powerig. Serious personal injury may occur if not connected in this order and disconnected in the reverse order.



CAUTIONS:

Do not use TEFLON® tape on pipe threads. Tape can shred, resulting in malfunctions.

Keep disconnected hoses and couplers and hydraulic fluid free of foreign matter. Contaminated fluid can cause valve failures.

Do not abuse this tool by dropping it, using it as a hammer, or otherwise causing unnecessary wear and tear. Never carry the tool by attached hoses.

GENERAL PRECAUTIONS

During disassembly and assembly, take the following precautions to avoid damaging tool or components:

- Use materials such as brass, aluminum, or wood, to protect tool when applying pressure.
- Apply continuous steady pressure, rather than sharp blows, to disassemble or assemble components. An arbor press provides steady pressure to press a component in or out.
- Never force a component if it "hangs up" due to misalignment. Reverse the procedure to correct misalignment and start over.
- Smear LUBRIPLATE® 130-AA (HUCK P/N **502723**) or equivalent on O-rings and mating surfaces to ease assembly and prevent damage to O-rings.
- Coat Parker Threadmate, Loctite 567, or Slic-tite stick to male pipe threads per manufacturer's instructions.

DISASSEMBLY AND ASSEMBLY TOOLS

Working on these tools requires the use of standard hand tools, such as wrenches, drifts, copper and lead hammers, screwdrivers, socket screw hexagon keys, and long forceps (tweezers). HUCK also recommends having access to an arbor press and vise with soft jaws. For specially-designed tools for working on this tool, see **KITS & ACCESSORIES**.

POWER SOURCE CONNECTIONS

Use a HUCK Powerig® Hydraulic unit, or equivalent, that has been suitably prepared for operation.

- Turn off the Powerig; disconnect its power supply.
- Apply Parker Threadmate, Loctite 567, or Slic-tite stick to male pipe threads per manufacturer's instructions, and then connect the hoses to the Powerig.
- Connect the tool control switch cord to Powerig.
- Connect the Powerig to the power supply and turn it on. Press and hold the tool trigger for 30 seconds; then press trigger a few times to cycle the tool and circulate the hydraulic fluid. Observe the action of the tool and check for leaks. Turn off the Powerig.
- Disconnect tool's control switch cord from the Powerig; disconnect the Powerig from the power supply. Select a nose assembly for the fastener to be installed and attach it to the tool.
- Reconnect the Powerig to the power supply and the tool's switch control cord to the Powerig.
- Check the operation of nose assembly; install fasteners in a test plate of correct thickness with proper size holes. Inspect installed fasteners.

NOTE: If fasteners do not pass inspection, see TROUBLESHOOTING to investigate possible causes.

Hydraulic Couplings



Use a fine India stone to remove any nicks or burrs from these areas to prevent damage to O-ring of Female



Operating Instructions

FOR SAFE OPERATION, THIS SECTION MUST BE READ AND UNDERSTOOD.

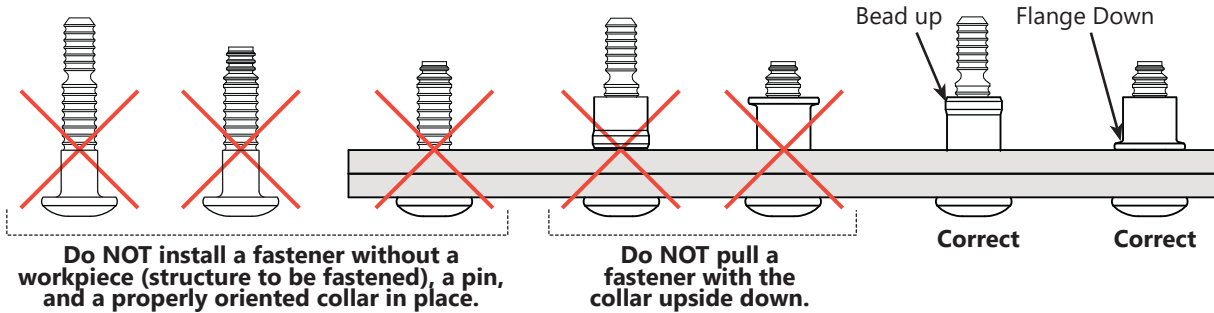

Do NOT install a fastener without a workpiece (structure to be fastened), a pin, and a properly oriented collar in place.

Do NOT pull a fastener with the collar upside down.

Correct

Correct



WARNINGS:

- To avoid severe personal injury, wear approved eye and ear protection. Be sure of adequate clearance for operator's hands before proceeding with fastener installation.
- If the tool comes with a pintail deflector or bottle, make sure it is attached to the tool and directed away from all personnel.
- Do NOT attempt to install a pin without placing the fastener and collar in the work piece (structure to be fastened).
- Do NOT attempt to install a pin without a properly oriented collar in place. The collar flange must be against work piece.
- If these safety measures are not followed, the fastener could eject with great velocity and cause severe personal injury. This condition can cause pin to eject with great velocity and force if the pintail breaks off or teeth/grooves strip. This may cause severe personal injury.
- To avoid pinch point, never place hand between nose assembly and work piece.
- Only use compatible equipment with this tool.



CAUTIONS: Remove excess gap from between the sheets. This permits enough pintail to emerge from collar for ALL jaw teeth to engage with pintail. If ALL teeth do not engage properly, jaws will be damaged.

Note: In certain situations, it may be permissible to use a BobTail tool and fastener without a collar to remove sheet gap prior to full installation with a collar. Consult qualified Huck engineering personnel before attempting this operation.

This section details installing HuckBolt® fasteners. Review all CAUTIONS and WARNINGS prior to installing these fasteners. If the tool malfunctions, consult **TROUBLESHOOTING** prior to attempting any repairs. Prior to starting these procedures, check the tool components drawing to verify the proper orientation of the flats on the dump valve; they should face the rear of the tool.

To install a HuckBolt® Fastener:

1. Place a fastener in the workpiece and place the collar over the fastener.
NOTE: The beveled end of the collar **must** be towards the nose assembly and tool.

2. Hold the fastener and push the nose assembly onto the fastener that is protruding through the collar until the nose anvil touches the collar.

NOTE: The tool and nose assembly must be at right angles (90°) to the workpiece.

3. Press and hold the trigger to start installation cycle.
4. Release the trigger when forward motion of nose assembly anvil stops and pintail breaks off.

The pressure is re-directed; the piston moves forward; and the tool is pushed off the fastener and ejects the pintail. The tool and nose assembly are ready for the next installation cycle.



Maintenance



CAUTIONS:

Replace all seals, wipers, O-rings and Back-up rings when the tool is disassembled for any reason, and at regular intervals, depending on severity and length of use.

Do not use TEFLON® tape on pipe threads. Tape can shred, resulting in malfunctions. Apply Parker Threadmate, Loctite 567, or Slic-tite stick to male pipe threads per manufacturer's instructions.

GENERAL

The operating efficiency of a tool is directly related to the performance of the entire system. Regular inspection and the immediate correction of minor problems will keep the tool operating efficiently, and prevent downtime. A schedule of preventive maintenance of the tool, nose assembly, hoses, trigger and control cord, and Powerig® hydraulic power source will ensure the tool's proper operation, extend its life, and reduce the risk of personal injury to those who operate it. **NOTE:** HUCK tools should be serviced only by personnel who are thoroughly familiar with its operation. Consult MSDS before servicing tool.

Service the tool in a clean, well-lighted area. Take special care to prevent contamination of pneumatic and hydraulic systems. Keep separated parts away from dirty work surfaces. Carefully handle all parts. Before reassembly, examine them for damage and wear. Disassemble and assemble tool components in a straight line. Do NOT bend, cock, twist, or apply undue force. Keep any relevant hand tools and HUCK Spare Parts Service Kits available. They include important consumable parts. Other components, as experience dictates, should also be available.

DAILY

If a Filter-Regulator-Lubricator unit is not being used, uncouple the air disconnects and add a few drops of hydraulic fluid to the air inlet of the tool. **NOTE:** If the tool is in continuous use, add a few drops of oil in every 2-3 hours. Before connecting an air hose to the tool, bleed the

air lines to clear dirt or water. Verify that hoses, fittings, couplings, and electrical connections are secure and free of leaks; tighten or replace if necessary. Check tools and nose assemblies for damage and air or hydraulic leaks; tighten, repair, or replace if necessary. Inspect the tool, hoses, and Powerig during operation to detect abnormal heating, leaks, or vibration. Clean nose assemblies in mineral spirits to clear jaws and rinse metal chips and dirt. For a more thorough cleaning, disassemble the nose assembly. Use a dull-pointed "pick" to remove embedded particles from the pull grooves of the jaws. Clean all parts of any assembly, and UNITIZED™ Jaws, in mineral spirits or isopropyl alcohol only. Do not let the jaws come in contact with other solvents. Do not soak jaws; dry them immediately after cleaning. Dry other parts before re-assembling.

WEEKLY

Disassemble, clean, and reassemble nose assemblies in accordance with applicable instructions. Check the tool and all connecting parts for damage and fluid/air leaks; tighten or replace if necessary. Inspect the cylinder bore, piston and rod/extension, and dump valve for scored surfaces, excessive wear, and damage; replace as necessary.

STICKERS

Stickers on the tool display safety and pressure-settings information, and must always be legible. For more information on sticker locations and part numbers, see Sticker Locations .

SPARE PARTS SERVICE KITS

HUCK Spare Parts Service Kits contain replacements or perishable tool parts. HUCK recommends having the appropriate kit accessible. For more information, see Kits and Accessories.

FLUID MAINTENANCE AND RECYCLED MATERIALS

See Specifications for information on approved fluid types. Dispose of fluid in accordance with local environmental regulations. Recycle steel, aluminum, and plastic parts in accordance with local lawful and safe practices.

Sticker Locations

HUCK tools are labeled with important stickers that contain safety and pressure-settings information. These stickers must remain on the tools and be legible. A sticker must be ordered and replaced on the tool, in the location shown, if it becomes damaged or worn, it has been removed from the tool, or when replacing the Cylinder.

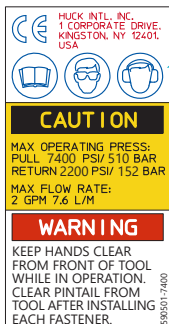

590501-7400_revA

590501-7400 CE & WARNING Sticker
(Maximum Operating Pressures)

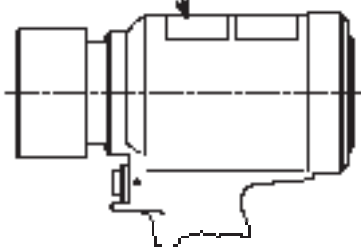

590517 HUCK &
Year of Mfr Sticker

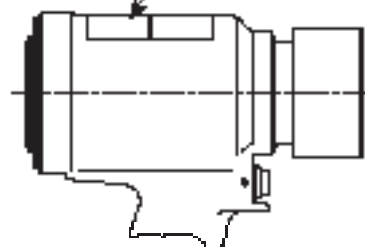

590517



Disassembly Procedure

This procedure is for complete disassembly of the tool. Disassemble **only** those components necessary in order to replace damaged O-rings, C-rings, Back-up rings, and worn or damaged components. Always use a soft-jaw vise to avoid damage to tool.

For component identification, see Figures 3 & 4.

To disassemble the tool:

NOTE: "P/N" indicates a part that is available from HUCK.

1. Disconnect the tool's electrical control trigger from the Powerig®; then uncouple the hydraulic hoses.



WARNING: Disconnect the tool control cord from the Powerig before disconnecting the hydraulic hoses from it. If not disconnected in this order, serious personal injury may occur.

2. Remove the sleeve and split ring. Remove the nose assembly.
3. Remove the coupler nipple and coupler body. Drain the hydraulic hoses into a clean container.
4. Push rearward on the piston until the hydraulic fluid is drained into the container.
5. Model **3585**: Remove the retaining ring and cover plate.
Model **3585PT**: Remove the screws and the retainer.
6. Model **3585**: Use the End Cap Hex Wrench (P/N **126981**) to remove the end cap.
Model **3585PT**: Use the End Cap Hex Wrench (P/N **126981**) to remove the end cap assembly.
7. Push rearward on the adapter assembly. The piston and adapter will slide from the cylinder.
8. Pull the piston out of the adapter, and remove the dump valve from the piston.

NOTE: Ejector gland assembly can be removed to inspect and/or replace components without disassembling tool. Use ejector gland wrench P/N 122048 to unscrew the assembly; then remove it and the pintail ejector from the piston.

9. Use a small-diameter, dull-pointed "pick" to remove O-rings and Back-up rings from all components.
10. Remove the socket head cap screw from the handle assembly.
11. Remove two button-head cap screws from one-half of the handle and cylinder.
12. Separate the handle halves and lift out the trigger switch assembly, strain relief, and control cord (including cord connector).

13. Remove the remaining button-head cap screws and handle half. Remove both hydraulic hoses from the cylinder.
14. Loosen two screws at the rear of the switch to remove the switch from the electrical cord. Remove two #6-32 socket setscrews to disassemble the switch. Pull the strain relief grommet from the cord.

The tool has been properly disassembled. Store all re-usable parts (screws and disassembled components) in a clean, dry area.



WARNING: Do NOT re-use seals, wipers, or rings; irreparable tool damage could occur. Discard these parts and use replacements (see **KITS & ACCESSORIES).**

NOTE: Disassemble the cord connector to rewire or replace it.



Assembly Procedure

This section details the re-assembly of the tool. For component identification, see Figures 3 & 4.

Prior to re-assembling the tool, HUCK recommends having the following items accessible.

NOTE: "P/N" indicates a part that is available from HUCK.

- The appropriate HUCK Spare Parts Service Kit (P/N **3585KIT** or P/N **3585PTKIT**)

NOTE: When re-assembling the tool, always replace damaged and defective parts, and all seals, wipers, O-rings, and Back-up rings of sub-assemblies.



WARNING: Do not omit any seals during servicing; leaks will result and serious personal injury can occur.

- LUBRIPLATE® 130-AA (available as P/N **502723**) or SUPER-O-Lube® (available as P/N **505476**)



CAUTION: Do not use TEFLON® tape on pipe threads. Tape can shred, resulting in malfunctions. Threadmate™ is available in a 4oz. tube from HUCK (P/N 508517).

Before re-assembling the tool:

- Clean components in mineral spirits or other solvent compatible with O-ring seals.
- Clean out O-ring grooves.
- Inspect components for scoring, excessive wear, and damage; replace as necessary.
- Replace O-rings and Back-up rings. See Assembly Drawings for guidance on positioning O-rings and Back-up rings.

When assembling the tool, take care not to damage O-rings, Quad-rings, Back-up rings.

- Smear LUBRIPLATE® 130-AA (HUCK P/N 502723) or SUPER-O-LUBE® (HUCK P/N 505476) on rings, and mating parts to ease assembly.

To re-assemble the tool:

- Assemble the electrical control cord to the plug of the electrical connector.
- Push the cord through the strain relief and attach it to the switch.
- Screw both hoses into the cylinder.
- Loosely attach the handle-half by turning two button-head cap screws into the cylinder.
- Place the assembled switch, electrical cord, strain relief, and electrical connector into the handle recesses. Tighten the four cap screws to 50lbs/in of torque (if plated) or 70lbs/in (if un-plated), while holding the assembled components in position.
- Assemble the ejector gland assembly and pintail

ejector to the piston as follows.

- Insert the pintail ejector into the piston.
 - Drop in the ejector washer.
 - Drop in the O-ring.
 - Make sure all ejector gland assembly parts (rings and wiper) are in place, then screw in the assembly. Use the Ejector Gland Wrench (P/N **122048**) to tighten the assembly.
- Push the nose adapter into the cylinder.
 - Install the retaining ring into the groove in the adapter.
 - Push the assembled piston and the assembled front gland (with all O-rings, Back-up rings, Polyseals, wiper, and wiper housing in place) into the assembled cylinder and adapter.
 - Slide the dump valve into the hole through the piston. Be sure the dump valve is assembled with four flats to the rear.
 - Use the End Cap Hex Wrench (P/N **126981**) to tighten the end cap, then back it off until the locator can be placed in closest matching grooves.
 - Model **3585**: After the end cap is locked in place, install the cover plate and retaining ring.
Model **3585PT**: After the end cap is locked in place, install the retainer and cap screws.
 - Screw the coupler nipple onto the hose in port P; screw the coupler body onto the hose in port R.
 - Connect the tool hoses to the Powerig® hydraulic power source hoses and cycle the tool a few times. Observe the action of the tool and check for leaks.
 - Attach the nose assembly to the tool following the applicable Nose Assembly Data Sheet. Use the split ring set and retaining sleeve furnished with tool.



WARNING: Make sure the tool has been properly re-assembled prior to use. Failure to do so could result in serious personal injury.



3585 Components Drawing

Figure 3

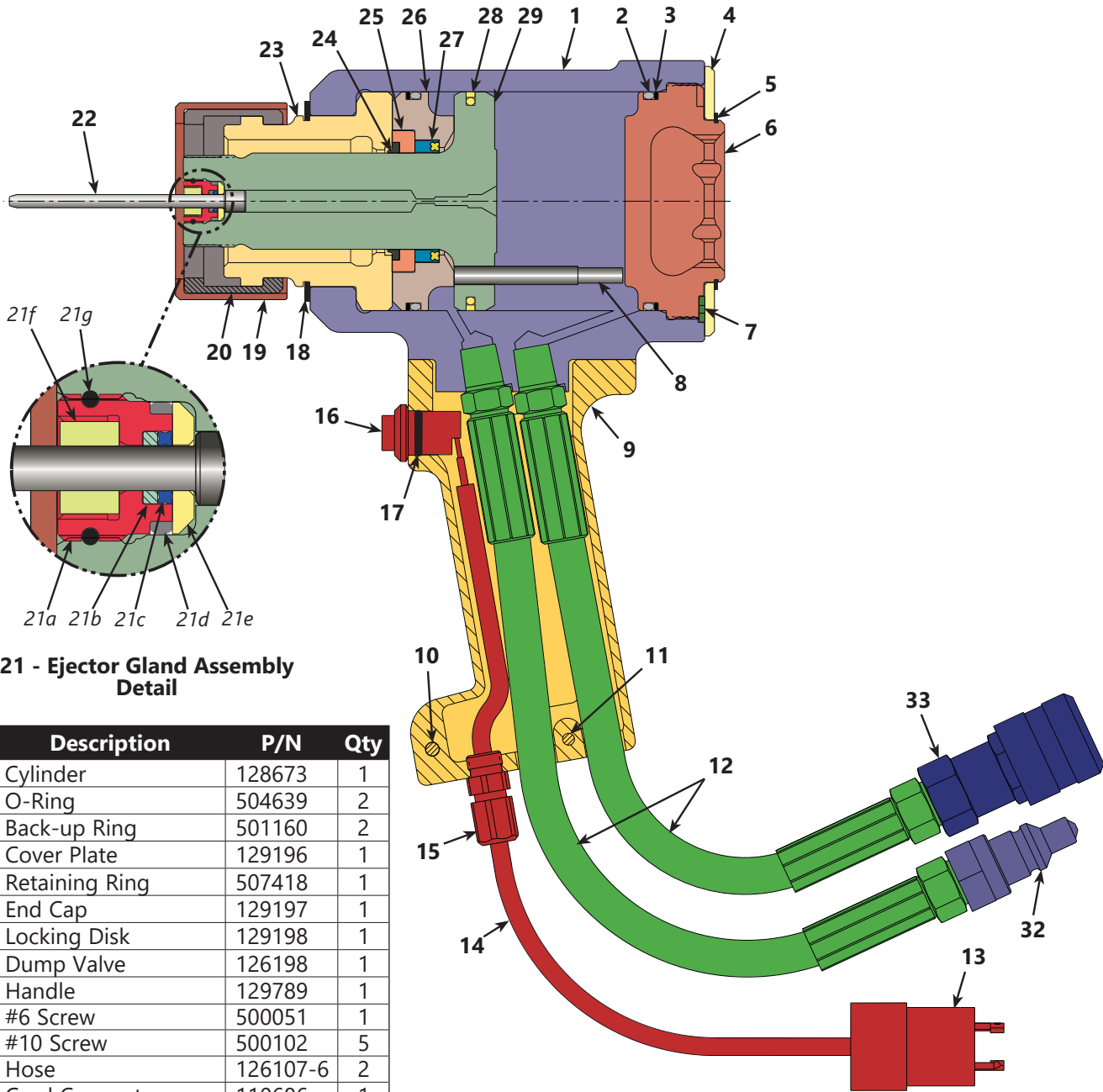

21 - Ejector Gland Assembly Detail

Item	Description	P/N	Qty
1	Cylinder	128673	1
2	O-Ring	504639	2
3	Back-up Ring	501160	2
4	Cover Plate	129196	1
5	Retaining Ring	507418	1
6	End Cap	129197	1
7	Locking Disk	129198	1
8	Dump Valve	126198	1
9	Handle	129789	1
10	#6 Screw	500051	1
11	#10 Screw	500102	5
12	Hose	126107-6	2
13	Cord Connector	110686	1
14	Control Cord	128705	1
15	Strain Relief	505344	1
16	Trigger Switch Assy	120361	1
17	Set Screw	501731	1
18	Retaining Ring	501030	1
19	Sleeve	100248	1
20	Split Ring	100247	1
21	Ejector Gland Assy	120653	1
21a	Gland	122047	1
21b	Back-up Ring	501080	1
21c	QUAD Ring	501411	1
21d	O-Ring	500779	1
21e	Ejector Washer	120652	1
21f	Ejector Rod Wiper	122742	1
21g	O-Ring	500779	1

Item	Description	P/N	Qty
22	Pintail Ejector	128742	1
23	Nose Adapter	128675	1
24	Wiper Seal	506001	1
25	Wiper Housing	125683	1
26	Front Gland	128674	1
27	Polyseal	507417	1
28	GLYD Ring®	509156	1
29	Piston	128703	1
30	HUCK Sticker	590247	1
31	Caution Sticker	590189-2	1
32	Male Connector	110438	1
33	Female Connector	110439	1



3585PT Components Drawing

Figure 4

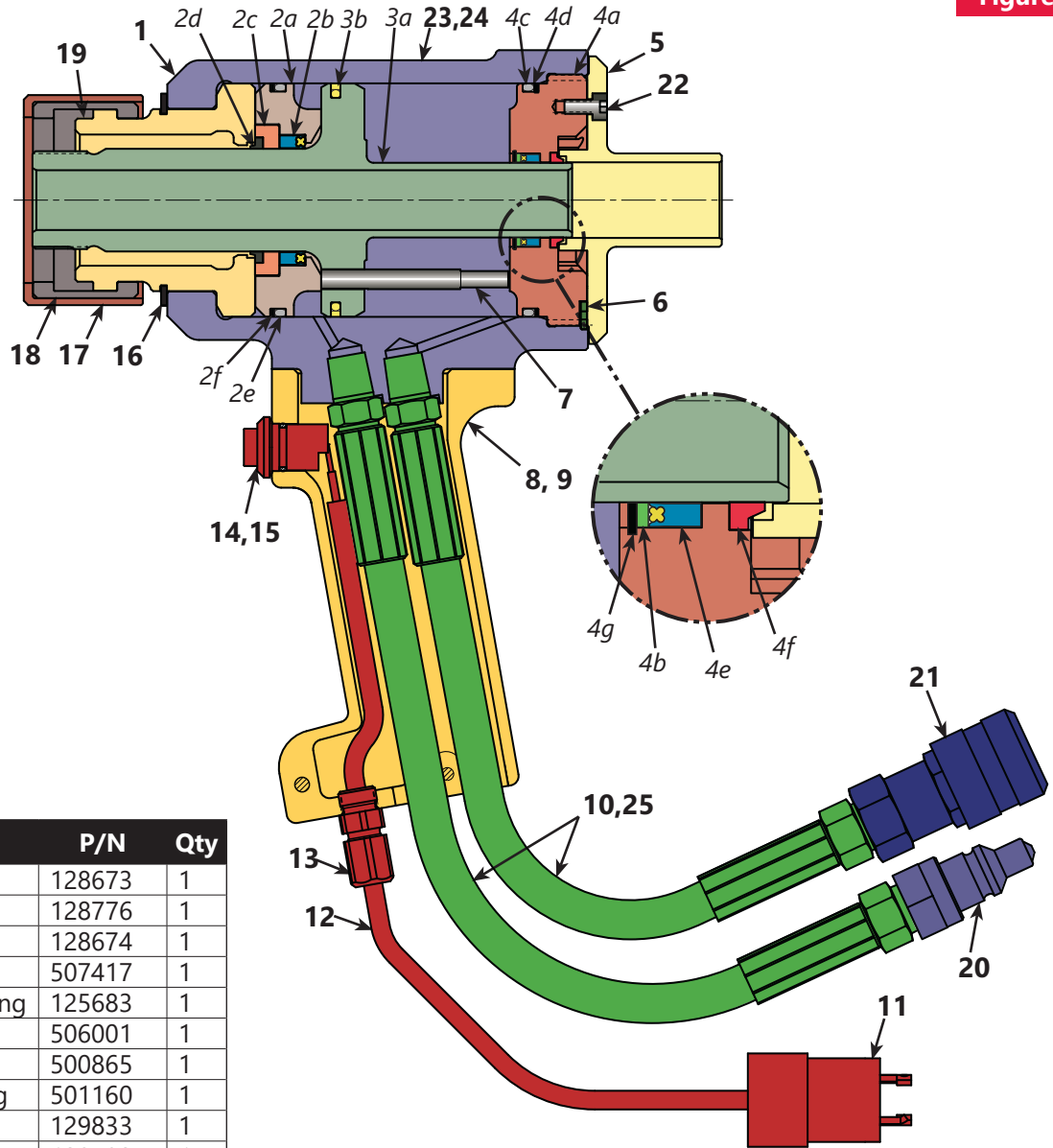

Item	Description	P/N	Qty
1	Cylinder	128673	1
2	Gland Assy	128776	1
2a	Front Gland	128674	1
2b	Polyseal	507417	1
2c	Wiper Housing	125683	1
2d	Wiper	506001	1
2e	O-Ring	500865	1
2f	Back-up Ring	501160	1
3	Piston Assy	129833	1
3a	Piston	129792	1
3b	GLYD Ring®	509156	1
4	End Cap Assy	129832	1
4a	End Cap	129791	1
4b	Spacer	129796	1
4c	O-Ring	504639	1
4d	Back-up Ring	501160	1
4e	Polyseal	507324	1
4f	Wiper Seal	508443	1
4g	Retaining Ring	508444	1
5	Retainer	129795	1
6	Locking Disk	129198	1
7	Dump Valve	129820	1
8	Handle	129789	1
9	Socket Hd Screw	500102	4
10	Hose	126107-2	2
11	Cord Connector	110686	1
12	Control Cord	129839	1
13	Strain Relief	505344	1

Item	Description	P/N	Qty
14	Trigger/O-Ring Assy	120361	1
15	Setscrew	501731	1
16	Retaining Ring	501030	1
17	Sleeve	100248	1
18	Split Ring	100247	1
19	Nose Adapter	128675	1
20	Male Connector	110438	1
21	Female Connector	110439	1
22	Screw	500060	3
23	HUCK Sticker	590247	1
24	Caution Sticker	590189-2	1
25	Cable Ties	505839	10



Kits and Accessories

The following product-specific Spare Parts Service Kits contain various perishable parts. The types and quantities of spare parts that should be available vary with the application and tools in use. Keep the appropriate kit and accessories on-hand when preparing, using, and performing maintenance on this tool.

KITS		Pressure Gauge	T-124833CE
Service Kits	3585KIT 3585PTKIT	Piston Assembly Tool Kit	123110-12
ACCESSORIES		<i>Contains:</i>	
Ejector Gland Wrench	122048	GLYD Ring® insertion tool	121694-2628
End Cap Hex Wrench	126981	Piston Assembly Tool	123111-7
Remote Trigger (all models)	123381	Spacer	123112-7

Troubleshooting

Always check the simplest possible cause (such as a loose or disconnected trigger line) of a malfunction first. Then proceed logically, eliminating other possible causes until the cause is discovered. Where possible, substitute known good parts for suspected defective parts. Use this Troubleshooting information to aid in locating and correcting trouble.

- 1. Tool fails to operate when trigger is pressed.**
 - a. Inoperative Powerig® Hydraulic Unit. See applicable instruction manual.
 - b. Loose air or electric connections.
 - c. Damaged trigger assembly.
 - d. Loose or faulty hydraulic hose couplings.
 - e. Dump valve not installed in tool.
- 2. Tool operates in reverse.**
 - a. Reversed hydraulic hose connections between hydraulic unit and tool.
- 3. Tool leaks hydraulic fluid.**
 - a. Defective tool O-rings or loose hose connections at tool.
- 4. Hydraulic couplers leak fluid.**
 - a. Damaged or worn O-rings in coupler body. See Coupler 110440.
- 5. Hydraulic fluid overheats.**
 - a. Hydraulic unit not operating properly.
 - b. Dump valve installed incorrectly.
 - c. Powerig Hydraulic Unit running in reverse (918: 918-5). See unit's manual.
- 6. Tool operates erratically and fails to properly install fastener.**
 - a. Low or erratic hydraulic pressure; air in system.
 - b. Damaged or worn piston O-ring in tool.
 - c. Dump valve installed incorrectly.
 - d. Excessive wear on sliding surfaces of tool parts.
 - e. Excessive wear of dump valve in tool.
- 7. Pull grooves on fastener pintail stripped during PULL stroke.**
 - a. Operator not sliding anvil completely onto fastener pintail.
 - b. Incorrect fastener grip.
 - c. Worn or damaged jaw segments.
 - d. Metal particles in jaw segments pull grooves.
 - e. Excessive sheet gap.
- 8. Collar of HuckBolt® Fastener not completely swaged.**
 - a. Improper tool operation. See Trouble 6.
 - b. Scored anvil.
- 9. Shear collar on HUCK Blind Fastener not driven.**
 - a. Improper tool operation.
 - b. Worn or damaged driving anvil in nose assembly.
- 10. Tool "hangs-up" on swaged collar of HuckBolt Fastener.**
 - a. Improper tool operation. See Trouble 6.
 - b. RETURN pressure too low.
 - c. Nose assembly not installed correctly.
- 11. Pintail of fastener fails to break.**
 - a. Improper tool operation. See Trouble 6.
 - b. Pull grooves on fastener are stripped. See Trouble 7.
 - c. PULL pressure too low.
 - d. Worn dump valve.



Notes



Limited Warranties

Limited Lifetime Warranty on BobTail® Tools:

Huck International, Inc. warrants to the original purchaser that its BobTail® installation tools manufactured after 12/1/2016 shall be free from defects in materials and workmanship for its **useful lifetime**. This warranty does not cover special order / non-standard products, or part failure due to normal wear, tool abuse or misapplication, or user non-compliance with the service requirements and conditions detailed in the product literature.

Two Year Limited Warranty on Installation Tools:

Huck International, Inc. warrants that its installation tools and Powerig® hydraulic power sources manufactured after December 1, 2016 shall be free from defects in materials and workmanship for a period of two years from date of purchase by the end user. This warranty does not cover special order / non-standard products, or part failure due to normal wear, tool abuse or misapplication, or user non-compliance with the service requirements and conditions detailed in the product literature.

90 Day Limited Warranty on Nose Assemblies and Accessories:

Huck International, Inc. warrants that its nose assemblies and accessories shall be free from defects in materials and workmanship for a period of 90 days from date of purchase by the end user. This warranty does not cover special clearance noses, or special order / non-standard product, or part failure due to normal wear, abuse or misapplication, or user non-compliance with the service requirements and conditions detailed in the product literature.

Useful lifetime is defined as the period over which the product is expected to last physically, up to the point when replacement is required due to either normal in-service wear, or as part of a complete overhaul. Determination is made on a case-by case basis upon return of parts to Huck International, Inc. for evaluation.

Tooling, Part(s) and Other Items not manufactured by Huck:

HUCK makes no warranty with respect to the tooling, part(s), or other items manufactured by third parties. HUCK expressly disclaims any warranty expressed or implied, as to the condition, design, operation, merchantability, or fitness for use of any tool, part(s), or other items thereof not manufactured by HUCK. HUCK shall not be liable for any loss or damage, directly or indirectly, arising from the use of such tooling, part(s), or other items or breach of warranty or for any claim for incidental or consequential damages.

Huck shall not be liable for any loss or damage resulting from delays or non-fulfillment of orders owing to strikes, fires, accidents, transportation companies or for any reason or reasons beyond the control of the Huck or its suppliers.

Huck Installation Equipment:

Huck International, Inc. reserves the right to make changes in specifications and design and to discontinue models without notice.

Huck Installation Equipment should be serviced by trained service technicians only.

Always give the serial number of the equipment when corresponding or ordering service parts.

Complete repair facilities are maintained by Huck International, Inc. Please contact one of the offices listed below.

Eastern

One Corporate Drive Kingston, New York 12401-0250
Telephone (845) 331-7300 FAX (845) 334-7333

Outside USA and Canada

Contact your nearest Huck International location (see reverse).

In addition to the above repair facilities, there are Authorized Tool Service Centers (ATSC's) located throughout the United States. These service centers offer repair services, spare parts, Service Parts Kits, Service Tool Kits and Nose Assemblies. Please contact your Huck Representative or the nearest Huck International location (see reverse) for the ATSC in your area.



**HOWMET
AEROSPACE**

Howmet Inc. (NYSE: HWM) creates breakthrough products that shape industries. Working in close partnership with our customers, we solve complex engineering challenges to transform the way we fly, drive, build and power.

Through the ingenuity of our people and cutting-edge advanced manufacturing, we deliver these products at a quality and efficiency that ensures customer success and shareholder value.

ISO 9001-2015

**CERTIFIED
MANAGEMENT
SYSTEM**

ISO 14001-2015

© 2021 Howmet Aerospace, Inc.
**Howmet Fastening Systems
Kingston Operations**



Huck provides technical assistance regarding the use and application of Huck fasteners and tooling. **NOTICE:** The information contained in this publication is only for general guidance with regard to properties of the products shown and/or the means for selecting such products, and is not intended to create any warranty, express, implied, or statutory; all warranties are contained only in Huck's written quotations, acknowledgments, and/or purchase orders. It is recommended that the user secure specific, up-to-date data and information regarding each application and/or use of such products.

Applifast.



251 Cree Crescent, Winnipeg, MB Canada R3J 3X4
Tel: 204 837 8361 • 1 800 563 1293
info@applifast.com



applifast.com