



The Huck[®] Solar System

Maintenance-Free
Fastening Solutions





**EVERYWHERE
THE SUN SHINES**

Solar Solutions That Revolve Around You

The Huck Solar System is a special selection of our top fasteners and tooling designed to match the unique needs of installing solar arrays with superior strength, corrosion resistance and clamping performance. Solar racking and PV installation has never been faster, easier, or more cost effective to complete.



Recent research done by a national energy company during a routine ten-year inspection at a solar farm found zero failures among thousands and thousands of Huck fasteners they used. Other fasteners in

the same location had issues of fatigue breakage, corrosion and loss of clamp force. The HuckBolts used on racking systems did not require a single day of maintenance.

Huck Overshadows All Other Fasteners

Our fastening technologies are known the world over for clamp performance that withstands the effects of vibration without ever loosening. After decades of applications in nearly every major industry, HuckBolts are well proven to never have to be inspected, tightened, or re-torqued. Sunrise to sunset, day in and day out, Huck delivers performance you can count on.

Maintenance-Free Holding Power

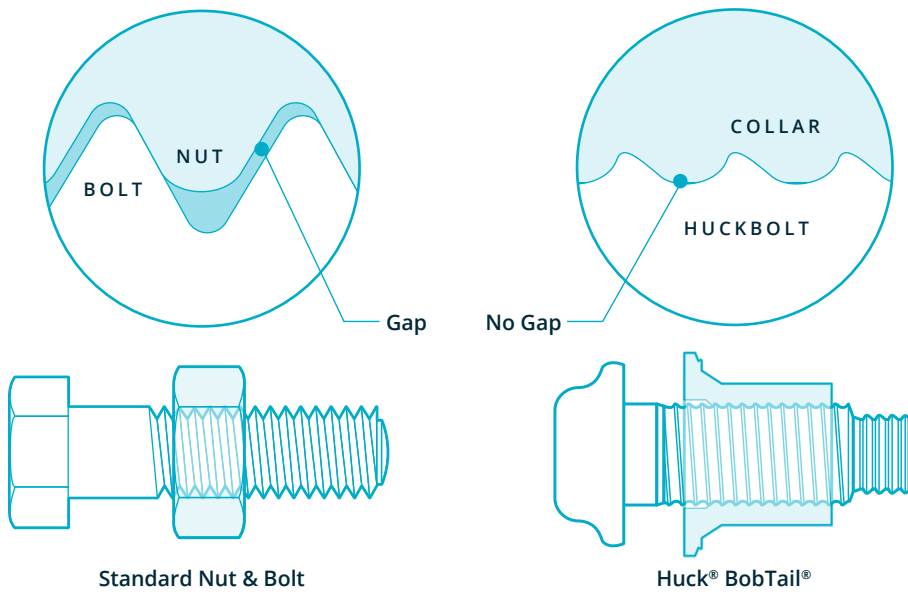

Conventional nut and bolt installations leave gaps between the threads that lead to loosening in high-vibration conditions. HuckBolts use a unique swaged metal collar that is pressed into the steel threads of the pin as part of the direct-tension installation process; thus eliminating these problematic gaps.

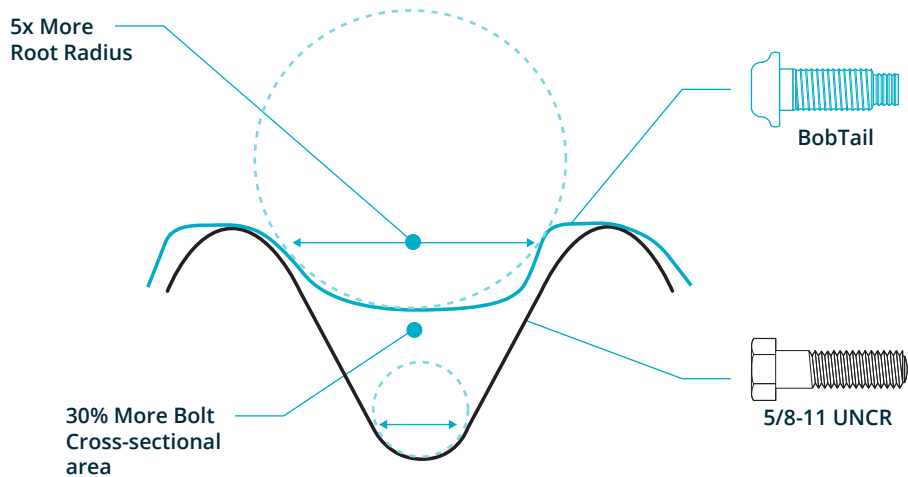

The unique design of our lockbolt pins have shallow locking grooves so they have a larger root radius than conventional nuts and bolts of the same size. This provides 30% more pin cross sectional area and improved notch factor for 5X improvement in bending and tensile fatigue strength.

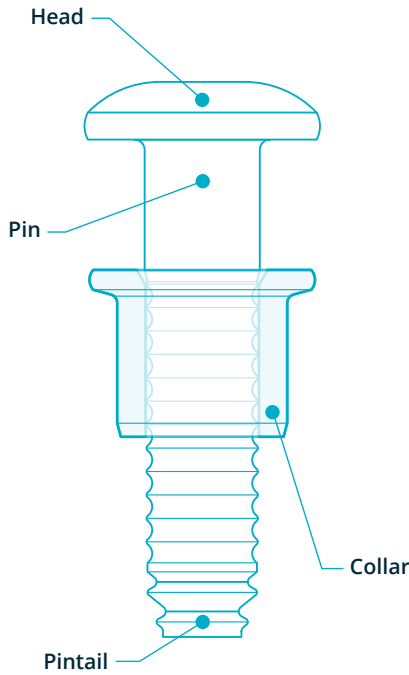

Fast, Reliable Installations

Installation of a Huck fastener is typically less than two seconds, and requires minimal training. A quick visual inspection is all that is needed to verify an accurate installation.



Corrosion has Met Its Match

Coatings for Huck fasteners are designed to fit your application conditions and applied at our fastener plant in Waco, Texas, to ensure quality control and speedy delivery.



Holding Power That Won't Shake Loose

HuckBolts are not subjected to the twisting force of torsion that a torque wrench applies to a conventional bolt. So they can safely be taken to higher preload values, resulting in higher clamp and the highest level of vibration resistance of any fastener, as shown in the Junkers Test results below.

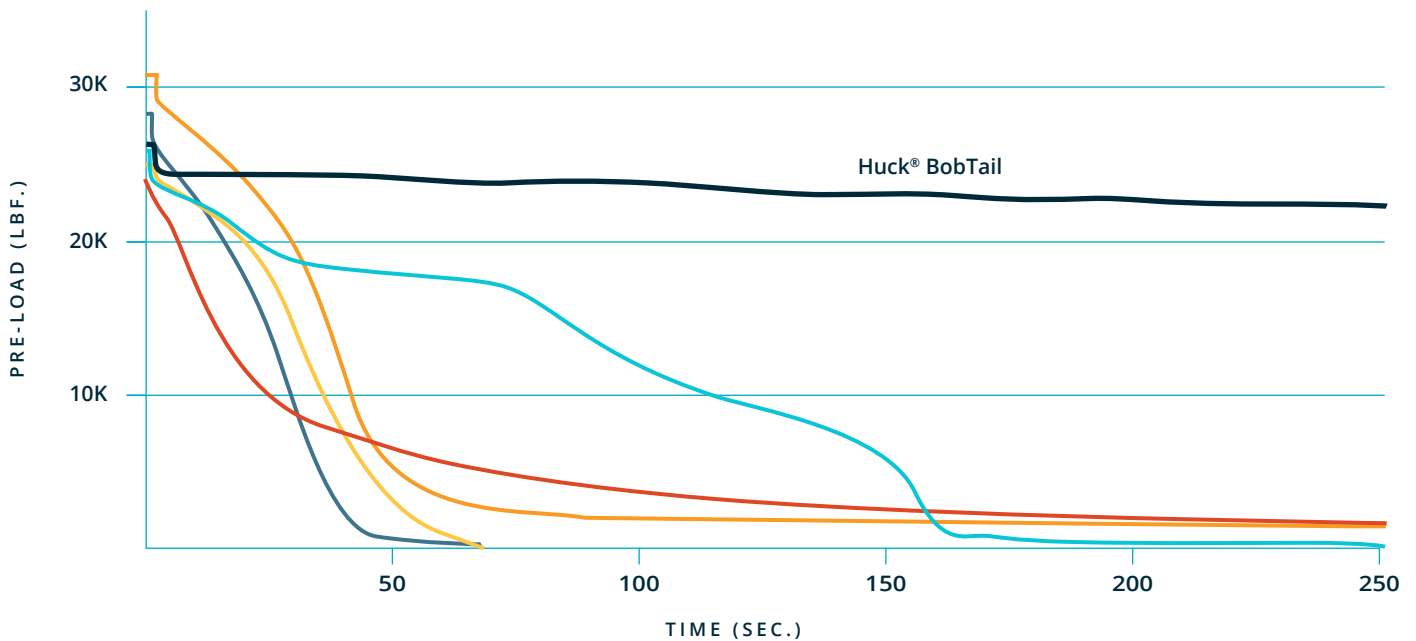

- Prevailing Torque Nylon Insert Nut
- Free Spinning 2-Piece Eccentric Nut
- Slotted Nut
- BobTail
- High Precision Unified Standard
- Prevailing Torque Eccentric UNC Nut

A Full Array of Solar Industry Fasteners

Huck makes solar array installation faster and more efficient with the strongest and most durable fasteners available for solar applications today. These fasteners include the BobTail HuckBolts, specialized blind bolts, structural blind rivets, and our unique 2-piece self-grounding BobTail that eliminates complex grounding assemblies. All Huck products are engineered for industry-leading installation efficiency and long-term reliability.

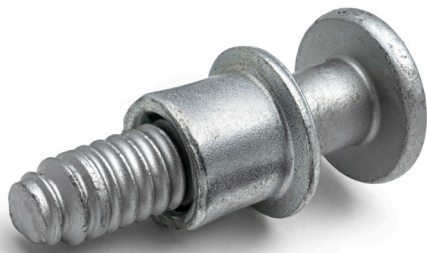

BobTail®

Engineered for high performance and reliability with a unique, pintail-less design, BobTail delivers up to 5 times the fatigue strength of conventional nuts and bolts, unmatched installation speed, and industry-leading vibration resistance.



Self-Grounding BobTail

All the fastening power of Huck BobTail fasteners with an added engineered solution that cuts through the surface of joined metals to ground itself and eliminate complex grounding assemblies. Simple visual inspection ensures proper installation.



Magna-Lok® Hole Filling Rivet

This moisture-resistant rivet features a unique circle-lock feature to allow simple visual inspection to confirm each fastener is installed properly. It is the best gap-pulling blind fastener available today and is manufactured in steel, stainless steel, 316 stainless steel or aluminum up to 1/2" in diameter.



BOM®

This is the highest strength blind fastener in the world. A single BOM can do the work of up to four conventional fasteners. Its unique push-and-pull installation design provides accurate, easy installation in seconds, and is often used to replace welding.

Tooling & Power Systems

Huck offers tooling and power systems especially designed to meet the unique installation requirements of solar framing and PV installation joints in the shop or in the field.



Range Force™ by Makita®

The Huck Range Force BV4500 and BV2200 are durable, full-featured battery tools with long 1.18" strokes and electronically adjustable pulling-force from 0 to 4500 pounds or 0 to 2200 pounds. These versatile performers install a wide variety of blind rivets as well as HuckBolt fasteners up to 1/4" in diameter.



SF20 Hydraulic

Huck's proprietary, advanced SWAGEFORWARD® tooling is designed to be a lightweight, high-performance tool for installation of BobTail fasteners. In tight, space-constrained applications, this tool allows the operator to position his or her hand at a safe distance from the working structure during installation.



A1100 Pneumatic

The Huck A1100 BT-Tool is specifically designed to install 1/4" aluminum BobTail fasteners. Light weight and easy to use, this tool operates on 90 psi of air pressure. Designed for demanding field use, the A1100 T-Tool features low maintenance requirements.

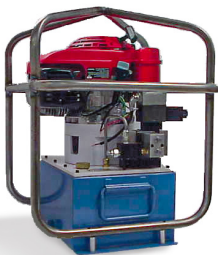

Powerig® Model 913F

The Huck Model 913F Powerig® is a portable, gasoline-fueled, hydraulic power source. This system is designed to operate all Huck hydraulic installation equipment in any environment where an air or electric source is not available.



Powerig Model 940

The Huck Model 940 Powerig is a portable unit sized for on-site installation applications. This unit features rugged construction for durability in the field, the choice of 115 or 220 Volt AC power, and includes a handle for easy transport.



2624PTD

The Huck 2624PTD is a lightweight ergonomic tool for high-speed installation of larger Huck fasteners. The tool features a 1.687 inch stroke, an in-line piston which extends seal life, and has only one moving part to minimize maintenance. Optional pintail collector available for use with structural blind rivets.



**HOWMET
AEROSPACE**

Howmet Fastening Systems

Industrial Division Brands



Huck, Marson, Recoil, Keysert, Camloc and Simmonds are trademarks of Howmet Aerospace Inc. and/or its subsidiaries.

The information contained in this publication is only for general guidance, and is not intended to create any warranty, express, implied, or statutory; all warranties are contained only in Howmet Fastening Systems' written quotations, acknowledgments, and/or purchase orders. It is recommended that the user secure specific, up-to-date data and information regarding each application and/or use of such products.

Applifast.



251 Cree Crescent, Winnipeg, MB Canada R3J 3X4
Tel: 204 837 8361 • 1 800 563 1293
info@applifast.com



applifast.com