



Instruction Manual

918 series

Powerig® Hydraulic Power Source



Table of Contents

Safety Instructions	3
Description	4
Specifications	5
Principle of Operation	5
Preparation for Use	6-7
Kits and Accessories	7
Checking and Adjusting Pressures	8
Operating Instructions	9
Maintenance	9
Components Drawings	
Components Overview	10-11
Electrical Schematics	12-13
Hydraulic Diagram	14
Hose & Control Cord Hook-up	15
Combination Valve Service Kit	16
Hydraulic Pumps	17-18
Front Bracket Assembly	19
Electrical Enclosure (918-5)	20
Electrical Control Panel	21
Control Panel Wiring	22-23
Suction Line	24
Return Line (918)	24
Return Line (918-5)	25
Troubleshooting	26







Safety Instructions

GLOSSARY OF TERMS AND SYMBOLS:

 - Product complies with requirements set forth by the relevant European directives.

 - Read manual prior to using this equipment.

 - Eye protection is required while using this equipment.

 - Hearing protection is required while using this equipment.

Notes: are reminders of required procedures.

Bold, Italic type, and underline: emphasize a specific instruction.

 **WARNINGS: Must be understood to avoid severe personal injury.**

 **CAUTIONS: Show conditions that will damage equipment or structure.**

1. A half hour long hands-on training session with qualified personnel is recommended before using Huck equipment.
2. Huck equipment must be maintained in a safe working condition at all times. Tools and hoses should be inspected at the beginning of each shift/day for damage or wear. Any repair should be done by a qualified repairman trained on Huck procedures.
3. Repairman and Operator must read manual prior to using equipment. Warning and Caution stickers/labels supplied with equipment must be understood before connecting equipment to any primary power supply. As applicable, each of the sections in this manual have specific safety and other information.
4. Read MSDS Specifications before servicing the tool. MSDS Specifications are available from the product manufacturer or your Huck representative.
5. When repairing or operating Huck installation equipment, always wear approved eye protection. Where applicable, refer to ANSI Z87.1 - 2003
6. Only genuine Huck parts shall be used for replacements or spares. Use of any other parts can result in tooling damage or personal injury.
7. If a part affixed with warning labels is replaced, or labels are missing or damaged, the end user is responsible for replacement. Refer to assembly drawing and parts list for replacement part number and proper placement.
8. Disconnect primary power source before performing maintenance on Huck equipment or changing Nose Assembly.
9. Tools and hoses should be inspected for leaks at the beginning of each shift/day. If any equipment shows signs of damage, wear, or leakage, do not connect it to the primary power supply.
10. Mounting hardware should be checked at the beginning of each shift/day.
11. Make sure proper power source is used at all times.
12. Release tool trigger if power supply is interrupted.
13. Tools are not to be used in an explosive environment unless specifically designed to do so.
14. Never remove any safety guards or pintail deflectors.
15. Where applicable, ensure deflector or pintail collector is installed and operating prior to use.
16. Never install a fastener in free air. Personal injury from fastener ejecting may occur.
17. Where applicable, always clear spent pintail out of nose assembly before installing the next fastener.
18. There is possibility of forcible ejection of pintails or spent mandrels from front of tool.
19. Check clearance between trigger and work piece to ensure there is no pinch point when tool is activated. Remote triggers are available for hydraulic tooling if pinch point is unavoidable.
20. Unsuitable postures may not allow counteracting of normal expected movement of tool.
21. Do not abuse tool by dropping or using it as a hammer. Never use hydraulic or air lines as a handle or to bend or pry the tool. Reasonable care of installation tools by operators is an important factor in maintaining tool efficiency, eliminating downtime, and in preventing an accident which may cause severe personal injury.
22. Never place hands between nose assembly and work piece. Keep hands clear from front of tool.
23. There is a risk of crushing if tool is cycled without Nose Assembly installed.
24. Tools with ejector rods should never be cycled with out nose assembly installed.
25. When two piece lock bolts are being used always make sure the collar orientation is correct. See fastener data sheet for correct positioning.
26. Tool is only to be used as stated in this manual. Any other use is prohibited.
27. There is a risk of whipping compressed air hose if tool is pneudraulic or pneumatic.
28. Release the trigger in case of failure of air supply or hydraulic supply.
29. Use only fluids or lubricants recommended.
30. Disposal instruction: Disassemble and recycle steel, aluminum and plastic parts, and drain and dispose of hydraulic fluid in accordance with local lawful and safe practices.
31. If tool is fixed to a suspension device, ensure that the device is secure prior to operating the tool.

918 series Powerig® Hydraulic Power Source (HK786)



Description

GENERAL

The models **918** and **918-5** HUCK Powerig® Hydraulic Units are electrically operated hydraulic power sources designed to operate Huck Installation Equipment.

Model **918** can operate **two** pieces of equipment simultaneously and independently of each other. The units are semi-portable and can be moved with a fork-lift truck.

Model **918-5** can operate **three** tools simultaneously and independently of each other. The 918-5 is the basic 918 with an additional combination valve bracket assembly mounted to the reservoir.

Figures 1 and 2 show features of model 918 and 918-5 POWERIG Hydraulic Units and identify main components. Hydraulic pressure is developed by an axial piston pump driven by an electric motor. Hydraulic pressure from the pump is directed to PULL and RETURN ports by combination valves controlled from the installation equipment by relays and solenoids.

Hydraulic fluid is stored in the 22 gallon (*83.3 liters*) reservoir which serves as a base for motor and pump. A 70 micron strainer in the suction line, and a 10 micron filter in the RETURN line, assure clean, filtered hydraulic fluid for the hydraulic system. A filler-strainer is provided for adding hydraulic fluid. However, any hydraulic fluid that is added to the reservoir must be filtered by a 10 micron (or better) filter.

Before returning to the reservoir, circulating hydraulic fluid passes through the cooler where the temperature of fluid is lowered to proper operating level. A fan, attached to the rear shaft extension of the electric motor, aids in dissipating heat from the cooler.

*Note: Kits are available for conversion from 440 to 220 volts and conversion from 220 to 440 volts.

ELECTRICAL CONTROL PANEL

The electrical control panel contains two compartments: **Disconnect Compartment** and the **Control/Transformer Compartment**. The **Disconnect Compartment** contains a three-pole main disconnect switch, three main line

fuses, two transformer fuses, and terminals for power cable connection.

The **Control/Transformer Compartment** contains two transformers (one is to convert to 110 and the other is to convert to 24 volt current), motor contact with three overload relays (heaters), multi-contact relays for control circuit, START and STOP buttons, 24 volt and 110 volt circuit breakers, bases (sockets) for plugging in the tool control cords, and power cable entrance connector.

INPUT POWER CABLE

A four-conductor power cable, including ground conductor, is used to connect the Powerig to the electrical power source. The cable is NOT shipped with unit. User must furnish power cable in accordance with his particular requirements. Only a qualified electrician should install power cable. (See the **First-time Start-up** procedure in the **PREPARATION FOR USE** section.)

The standard 440-volt unit can be converted to 220-volt operation with conversion kit **918-220KIT**. The 220-volt unit can be converted to 440-volt operation with conversion kit **918-440KIT**.

COMBINATION VALVE

Each combination valve contains a **Four-way solenoid-operated directional valve, Pressure Relief Valve, and Idler Valve**.

The **Four-way Valve** is controlled by a tool trigger through a relay and solenoid, and directs hydraulic fluid under pressure to PULL or RETURN hoses connected to installation tool, or other equipment.

The **Pressure Relief Valve** protects the POWERIG and installation tools from excessive pressure during the *pull* cycle. The valve is factory preset to 5600 psi (*386 BAR*).

The **Idler Valve** (Figure 7) protects the POWERIG and installation tools from excessive pressure during the *return* cycle. The Idler Valve is factory preset to provide 2800 psi (*193 BAR*) return pressure and approximately 200 psi (*14 BAR*) idling pressure.

NOTE: Various systems require different output pressures. See CHECKING & ADJUSTING PRESSURES before using the POWERIG Hydraulic Unit.



Specifications

NOTE: The units are shipped without hydraulic fluid.

CSA CERTIFIED



UNIT	WIDTH inch (cm)	LENGTH inch (cm)	HEIGHT inch (cm)	WEIGHT lbs. (kg)	OPERATIONAL WEIGHT lbs. (kg)
918	25.0 (63.5)	44.0 (111.8)	30.0 (76.2)	585 (265)	708 (321)
918-5	29.0 (73.7)	44.0 (111.8)	30.0 (76.2)	601 (272)	724 (328)

918 series Powerigs are intended for use in indoor factory environments. If used outdoors, they must be protected from the elements.

SYSTEMS:

918: Two (2) open-center circuits with 8,400 psi (580 BAR) maximum operating pressure

918-5: Three (3) open-center circuits with 8,400 psi (580 BAR) maximum operating pressure

POWER SOURCE:

10 HP (7.46 kw) Reuland electric motor 220 VAC (27.6A), 440 VAC (13.8A), or 550 VAC (10.8A), 3 phase; 60 Hertz; or 8.3 HP (6.19 kw) Reuland electric motor 380 VAC (13A), 3 phase; 50 Hertz. For other voltages and frequencies, contact Alcoa Fastening Systems & Rings, Fasteners Division, Kingston Operations.

PUMP:

Dynex/Rivet constant-displacement hydraulic piston pump, direct mounted to motor. Pump has six axial pistons. Flow is split: 3 pistons per circuit in 918; 2 pistons per circuit in 918-5

FLUID CONTROL:

Four-way solenoid-operated directional valve, pressure relief valve, and idler valve on each circuit.

RESERVOIR CAPACITY:

22.0 gallons (83.28 liters) center of sight gauge

COOLER:

Fan and radiator air/oil heat exchanger

REMOTE CONTROL:

24 volt AC control circuit

OUTPUT PRESSURE:

PULL range: 5,800–8,400 psi (400–580 bar)

RETURN range: 800–7,000 psi (55–482 bar)

MAX FLOW RATE:

918: 2.0 gpm (7.6 l/m) per circuit

918-5: 1.33 gpm (5.0 l/m) per circuit

MAX OPERATING TEMP:

125° F (51.7° C)

HOSE KITS:

Use only genuine Huck Hose Kits rated @ 10,000 psi (689.5 BAR) working pressure.

HYDRAULIC FLUID:

Hydraulic fluid shall meet DEXRON® III, DEXRON VI, MERCON®, Allison C-4 or equivalent Automatic Transmission Fluid (ATF) specifications. Fire-resistant fluid may be used if it is an ester-based fluid such as Quintolubric® HFD or equivalent. Water-based fluid shall NOT be used as serious damage to equipment will occur.

Where the following trade names are used in this manual, please note:

DEXRON is a registered trademark of General Motors Corporation.
GLYD Ring is a registered trademark of Trelleborg Sealing Solutions Germany GmbH

Loctite is a registered trademark of Henkel IP & Holding GmbH
LUBRIPLATE is a registered trademark of Fiske Brothers Refining Co.
MERCON is a registered trademark of Ford Motor Corp.

MOLYKOTE is a registered trademark of Dow Corning Corporation
Never-Seez is a registered trademark of Bostik, Inc.

Quintolubric is a registered trademark of Quaker Chemical Corp.
Slic-tite is a registered trademark of LA-CO Industries, Inc.

Spirolox is a registered trademark of Smalley Steel Ring Company
Teflon is a registered trademark of Chemours Company FC.

Threadmate is a registered trademark of Parker Intangibles LLC.
TRUARC is a trademark of TRUARC Co. LLC.

Vibra-Tite is a registered trademark of ND Industries, Inc. USA.

Principle of Operation

See Figures 3 and 4, **ELECTRICAL SCHEMATICS**, and Figure 5, **HYDRAULIC DIAGRAM**. With the disconnect switch ON, input power is supplied to open motor contacts and to the transformer which develops 110 volts AC across its secondary.

When the START button is momentarily pressed, the circuit is completed through the motor contact, closing the contacts and starting the motor. The START button is now bypassed by a closed motor contact and the motor continues to run when the START button is released, unless the STOP button is pressed or the overload relay in the motor contact opens due to motor overload.

After the START button is pressed, 24 volts AC is developed across the secondary of transformer for the tool control circuits. When tool trigger 1 is pressed, relay 1CR energizes, closing its contacts in the operating solenoid circuit. This action energizes the solenoid, changing the position of the directional valve spool so that high-pressure hydraulic fluid is directed out the PULL pressure port and hose to Tool 1.

When the tool trigger is released, the solenoid de-energizes and the valve spool returns to its original position, directing the hydraulic fluid out the RETURN pressure port and hose to the tool. Each tool has a control circuit that allows it to operate simultaneously and independently.



Preparation for Use



WARNINGS:

Only a qualified electrician is to install the power cable, according to local electrical codes, and service the electrical control and disconnect panel.

ALWAYS CONNECT PRIMARY POWER SOURCE FROM HYDRAULIC UNIT WHEN ANY MAINTENANCE IS PERFORMED ON UNIT, including opening any panels or access doors. SEVERE ELECTRICAL BURNS and/or ELECTROCUTION MAY RESULT IF THIS PRECAUTION IS NOT TAKEN. Other severe injuries may occur from mechanical components such as the fan if motor starts up.

See PULL and RETURN pressures listed in applicable tool instruction manual. Improper settings of PULL and RETURN pressures could cause violent rupture of the system or tool. Fatal or severe injury from exploding components/hydraulic fluid could occur to anyone in the immediate vicinity.



CAUTIONS:

Always prime pump after filling reservoir.

Do not use TEFLON® tape on pipe threads. Tape can shred and break free into fluid lines, resulting in malfunctions. Apply Parker Threadmate, Loctite 567, or Slic-tite stick to male pipe threads per manufacturer's instructions.

NOTE: Electric current and PULL and RETURN pressure requirements must be understood before preparing these Powerig® Hydraulic Units for first-time use. Set PULL and RETURN pressures for each tool according to tool instruction manual. Electric current to be used:

- 440 volts, 60 Hz, 3 phase; or
- 550 volts, 60 Hz, 3 phase; or
- 380 volts, 50 Hz, 3 phase.

GOOD SERVICE PRACTICES

Foreign material in the hydraulic system results in poor performance and repair down time. To avoid this, observe the following good service practices:

1. Clean area around reservoir filler cap before removing it.
2. When adding hydraulic fluid to the reservoir, use a clean funnel and filter the fluid with a 10 micron filter.
3. Do not let hose fittings and couplers lay on or drag around on a dirty floor, or on the ground.

FIRST TIME START-UP

1. Check that drain plug and hydraulic fluid beater port plugs are tight.
2. Fill reservoir with hydraulic fluid (approx. 22 gallons) until fluid level is in middle of fluid level gauge.
3. Remove plastic shipping plugs from PULL and RETURN pressure ports of TOOL 1, TOOL 2, (and for 918-5: TOOL 3).

4. Connect installation tools.
5. Remove POWERIG Hydraulic Unit hood.
6. Remove pipe plug in service tee in suction line. Use 5/8 inch hex key, P/N 504249.
7. Turn fan by hand to prime pump. Add fluid until pump is filled level with top of service tee. Reassemble pipe plug. Use TEFLON stick type thread compound.

220*, 380, 440* OR 550 VOLT, 3-PHASE OPERATION

1. Turn disconnect switch to OFF (see WARNING above) and open covers or electrical control panel.
2. Bring 220, 380, 440 or 350 volt, three-phase input cable (4 conductors) into disconnect compartment through hole in front of panel and secure with connector furnished.
3. Remove line shield.
4. Connect power cable leads to terminals L1, L2, and L3. Replace line shield.
5. Connect ground wire (green) to ground terminal provided. Tighten nut on ground connection securely.
6. Close covers of electrical control panel.
7. Connect power cable to input power source.
8. Turn disconnect switch to ON and push START button.
9. Check that motor rotation is in the same direction as arrow on motor cover. To reverse rotation, disconnect power cable from power source, turn disconnect switch to OFF and open covers. Remove line shield. Change position of any two wires connected to terminals L1, L2, or L3. Replace line shield. Close covers. Connect power cable to power source. Turn disconnect switch to ON and push START button.
10. Let hydraulic unit operate for approximately five minutes to remove air from hydraulic fluid circuit. Check for leaks.
11. Push STOP button.
12. Check fluid level and add hydraulic fluid if necessary.
13. Reinstall hood.
14. Check output pressures. See Checking & Adjusting Pressures section of this manual.

REGULAR USE BEFORE EACH OPERATION

1. Check hydraulic fluid level in reservoir and add hydraulic fluid as required. Whenever hydraulic fluid is added, it must be filtered by a 10-micron filter.
2. Never operate unit without hood in place.
3. Inspect hoses for damage, and replace as required.
4. Check and correct any leaks.
5. Connect power cable to power source compatible with internal wiring of unit.

CONNECTING INSTALLATION TOOLS TO POWERIG

Figure 6 shows a typical hose and control cord hook-up. Hose and cord kits for connecting Installation Tools to the unit are shown in the **KITS AND ACCESSORIES** section of this manual. Be sure that hose from port P of tool is connected to PULL pressure port on POWERIG Hydraulic Unit, and hose for port R of tool is connected to RETURN pressure port of unit.



Preparation for Use continued

Assembly of NPTF Threaded Components

AIR FITTINGS

- 1) Apply TEFLON® stick to male threads which do not have pre-applied sealant per manufacturer's recommendations. (Proceed to All Fittings step 2)

HYDRAULIC FITTINGS

- 1) Apply Threadmate™ to male and female threads which do not have pre-applied sealant per manufacturer's recommendations. (Proceed to All Fittings step 2)

ALL FITTINGS:

- 2) Tighten to finger-tight condition.
- 3) Wrench tighten to 2-3 turns past finger-tight condition.

- 4) Final thread engagement can be checked (optional) by measuring the dimension from the flange of male fitting to the end of the thread before assembly and subtracting the distance under the flange after assembly.

Thread Size	Final thread engagement at full make-up
1/8-27 NPTF	.235 inch (.59 cm)
1/4-18 NPTF	.339 inch (.86 cm)
3/8-18 NPTF	.351 inch (.89 cm)

Hydraulic Couplings



Use a fine India stone to remove any nicks or burrs from these areas to prevent damage to O-ring of Female

Kits & Accessories

Huck offers a variety of kits for use with the Powerig®. These kits simplify parts ordering for maintenance and operation. Use these kits to harness extra heat in cold-weather situations, extend the reach of the Powerig, or convert voltage. **To maintain safe pressure at the Powerig, and working pressure at the tool, do NOT exceed 156 ft. (47.5 m) of hose length. Hose and Control Cord Kits can be coupled using Quick Disconnects and Adapter Unions (P/N 503697); these parts must be ordered separately. The hoses in these kits are rated by the manufacturer for 10,000 psi (689.5 BAR) maximum working pressure.**

Hose and Control Cord Kit (12 ft. hose) 110838

Hydraulic Quick Disconnects (male and female) - 110440
Hose and Control Cord Assembly - 110847

Hose and Control Cord Kit (26 ft. hose) 110839

Hydraulic Quick Disconnects (male and female) - 110440
Hose and Control Cord Assembly - 110848

Hose and Control Cord Tube - n/a

Control Cord - 110525

Hose and Control Cord Kit (52 ft. hose) 110841

Hydraulic Quick Disconnects (male and female) - 110440
Hose and Control Cord Assembly - 110848 (qty. 2)
Adapter Union - 503697 (qty. 2)

Hydraulic Quick Disconnects 110440

This pair of quick disconnects provides a positive, easy connection for tool hoses to Powerig hoses. This set contains one female connector and one male connector.

Pump Shaft Kit, part number 122463

See Figure 8

Pressure Checking Gauge T-124833CE

Huck recommends that maintenance personnel do periodic checks with Pressure Checking Gauge T-124833CE.



WARNING: Abnormally high pressure can cause sudden failure of the Powerig, and excessive wear. Severe personal injury could result.

Auxiliary Electric Trigger Assembly 113056

contains a switch, housing, and a 13-foot (3.9 meter) cord.

Control Cord Connector Set 110835

Replacement Control Cord Connector Set

Hydraulic Fluid Heater Kit 110907

This optional Heater Kit for cold weather has two heater elements and related components with instructions included.

Pump Seal Kit 110933

contains shaft seal and O-rings for overhauling one hydraulic pump.

Voltage Changing Conversion Kits

for changing unit from 440V to 220V: **918-220KIT**

for changing unit from 220V to 440V: **918-440KIT**

Power Switch Conversion Kit 131555

contains all parts necessary to convert older disconnect switch assembly to the new-style. Any unit built before March 2018 has the older style, which was discontinued by the manufacturer.



Checking & Adjusting Pressures



WARNINGS:

Turn OFF the Powerig prior to connecting or disconnecting tools. If it is necessary to connect or disconnect a tool while the unit is running, use the following procedure for maximum safety.

Connect tool's hydraulic hoses to unit before connecting tools switch control cord to unit. If a malfunctioning cord switch is connected first, hydraulic unit may begin to cycle unexpectedly. Unexpected cycling may lead to serious injury. When connecting hoses, switch MUST be connected last. Just as important: When disconnecting hoses, switch MUST be disconnected first.

Maximum PULL pressure is 8400 psi (648 bar). Refer to specific tool instruction manual for PULL and RETURN pressures for Huck installation equipment. Severe personal injury may occur if excessive pressures cause violent failure of equipment.

PREPARATION FOR USING GAUGE T-124833CE

If necessary, prime and bleed the POWERIG® Hydraulic Unit. See the **PREPARATION FOR USE** section of this manual. **NOTE: Check each tool's pressure separately.**

1. Turn OFF the POWERIG. Connect the male coupler of gauge to PULL pressure female coupler of Powerig.
2. Connect female coupler of gauge to RETURN pressure male coupler of Powerig.
3. Turn needle valve of T-124833CE all the way out.
4. Install auxiliary electric switch and control cord assembly (P/N 113056) in the control cord socket of the tool port being checked, or use the trigger of the tool connected to the ports being checked. Fluid will be directed out the PULL pressure port when the switch is pressed. Connect the Powerig to the primary power source and turn it ON.

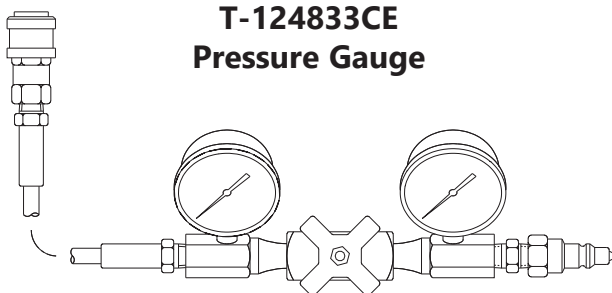

T-124833CE
Pressure Gauge



CAUTION: The following check must be completed quickly. Sustained high pressure will cause premature wear on the unit.

CHECKING OUTPUT PRESSURES USING T-124833CE

1. Close the valve (turn handle clockwise). Press and hold auxiliary trigger switch. Read the PULL pressure on right gauge. Release trigger switch.
2. Open valve by a few counterclockwise handle turns.
3. **Press** and **Release** auxiliary trigger switch to set the unit's internal valve. Hydraulic fluid is directed out RETURN pressure port.
4. **SLOWLY** close the valve. The pressure will rise, and then sharply drop. Read the RETURN pressure on the left gauge just before the pressure drops.
5. Open the valve. Turn OFF the Powerig.



WARNING: Turn OFF the hydraulic unit. Accidental cycling of the unit may cause severe injury when disconnecting couplings. Fluid may unexpectedly spray.

6. Disconnect auxiliary trigger, then pressure setting gauge.
7. Refer to installation tool's instruction manual for specific PULL and RETURN pressures.

ADJUSTING OUTPUT PRESSURES

The POWERIG Hydraulic Unit should be prepared for operation as described in **PREPARATION FOR USE**. Use Gauge T-124833CE to check pressures before and after adjusting PULL and RETURN pressures.

ADJUSTING COMBINATION VALVE P/N 119740

The 918 and 918-5 POWERIG Hydraulic Units are equipped with valves that can be set at specific PULL and RETURN pressures (see the applicable instruction manual for your tool). There is a socket-head screw to adjust PULL pressure and a different one to adjust RETURN pressure. See Figure 7.



CAUTION: Whenever possible, set Powerig pressures to the lowest recommended pressure to minimize wear on the equipment.

PULL PRESSURE ADJUSTMENT

Use 5/16" hex key for PULL pressure adjusting screw.

- Turn adjusting screw clockwise to increase pressure.
- a. Turn adjusting screw counterclockwise to decrease pressure.
 - c. Check resulting PULL pressure setting with Gauge T-124833CE.

RETURN PRESSURE ADJUSTMENT

Use 5/16" hex key for adjusting screw.

- a. Turn adjusting screw clockwise to increase pressure.
- b. Turn adjusting screw counterclockwise to decrease pressure.
- c. Check resulting RETURN pressure setting with Gauge T-124833CE.



Operating Instructions



WARNING: Severe personal injury may result if connections or hoses fail.

Before operating the Powerig® Hydraulic Power Source, make sure unit has been prepared for service as described in **PREPARATION FOR USE**. Connect hoses and control cords as shown in **CONNECTING INSTALLATION TOOLS TO POWERIG HYDRAULIC UNIT**.

1. Connect power cable to proper power source.
 2. Turn Power Switch to ON.
 3. To start unit, push START button and then release.
 4. Push STOP button to stop unit.
 5. Press tool trigger to cycle tool. (When trigger is pressed, tool piston will retract. When trigger is released, tool piston will return.)
- ALWAYS BE ALERT FOR:**
- (a) leaks at hose connections,
 - (b) damage to hoses, and
 - (c) hydraulic fluid level.

Maintenance



WARNINGS:

Only a qualified electrician is to install the power cable, according to local electrical codes, and service the electrical control and disconnect panel.

ALWAYS DISCONNECT PRIMARY POWER SOURCE FROM HYDRAULIC UNIT WHEN PERFORMING MAINTENANCE. This includes opening panels and access doors. **SEVERE ELECTRICAL BURNS OR ELECTROCUTION MAY RESULT IF THIS PRECAUTION IS NOT TAKEN.** Other serious injuries may occur from mechanical components, such as the fan, if the motor unexpectedly starts.

After overhauling combination valve, **PULL and RETURN pressures must be checked.** Serious personal injury may occur if excessive pressure causes violent hose or installation equipment failure.

Excessive pressures may cause violent rupture of some part of the fastening system. Exploding components may cause severe or fatal injuries to personnel in the vicinity. If the system does not rupture, continuous higher than normal pressure will cause premature wear of equipment.



CAUTION: Do not operate POWERIG if line voltage is lower than 5 percent below normal.

PREVENTIVE MAINTENANCE

1. Inspect hydraulic and electrical fittings to be sure they are secure.
2. Inspect hoses frequently for signs of damage. Replace hoses if damage is detected.
3. Inspect during operation to detect any abnormal heating, vibration or leakage.
4. Inspect hydraulic fluid periodically and replace if contamination is detected. Clean sump filter if fluid is dirty and being replaced. NOTE: Light on bulkhead will come on when filter is dirty and oil should be replaced.
5. Keep hood in place and keep all exterior surfaces clean.
6. Replace oil filter every six months or if oil filter light on bulkhead comes on. A filter element can be ordered from Huck, part number 507089.
7. Do not block ventilation louvers at end of unit. Maintain a minimum of 4 inches of clearances from louvers to wall or solid object.

COMBINATION VALVE OVERHAUL

Combination valves should be returned to the nearest repair facility shown on the inside of the back cover of this manual if a major overhaul is necessary. Minor overhaul includes cleaning and replacing seals, perishable parts and high wear components. Huck recommends only minor overhaul by the user. One spare combination valve should be kept on hand for each POWERIG Hydraulic Unit.

Smear LUBRIPLATE 130AA, or hydraulic fluid, on O-rings and other components when reassembling combination valve. See Figure 7 for position of all components.

OUTPUT PRESSURES

To prevent malfunctions, check and adjust PULL and RETURN pressures of Powerig® Hydraulic Power Source. Check pressures when:

- Unit is being used for the first time.
- Any part of combination valve is repaired.
- Combination valve is replaced.
- Troubleshooting is to be performed.
- Before any tool is connected.
- Whenever tool does not perform as expected.
- Whenever unsure of the pressure setting.

918 series Powerig® Hydraulic Power Source (HK786)



918 & 918-5 Front View

Figure 1

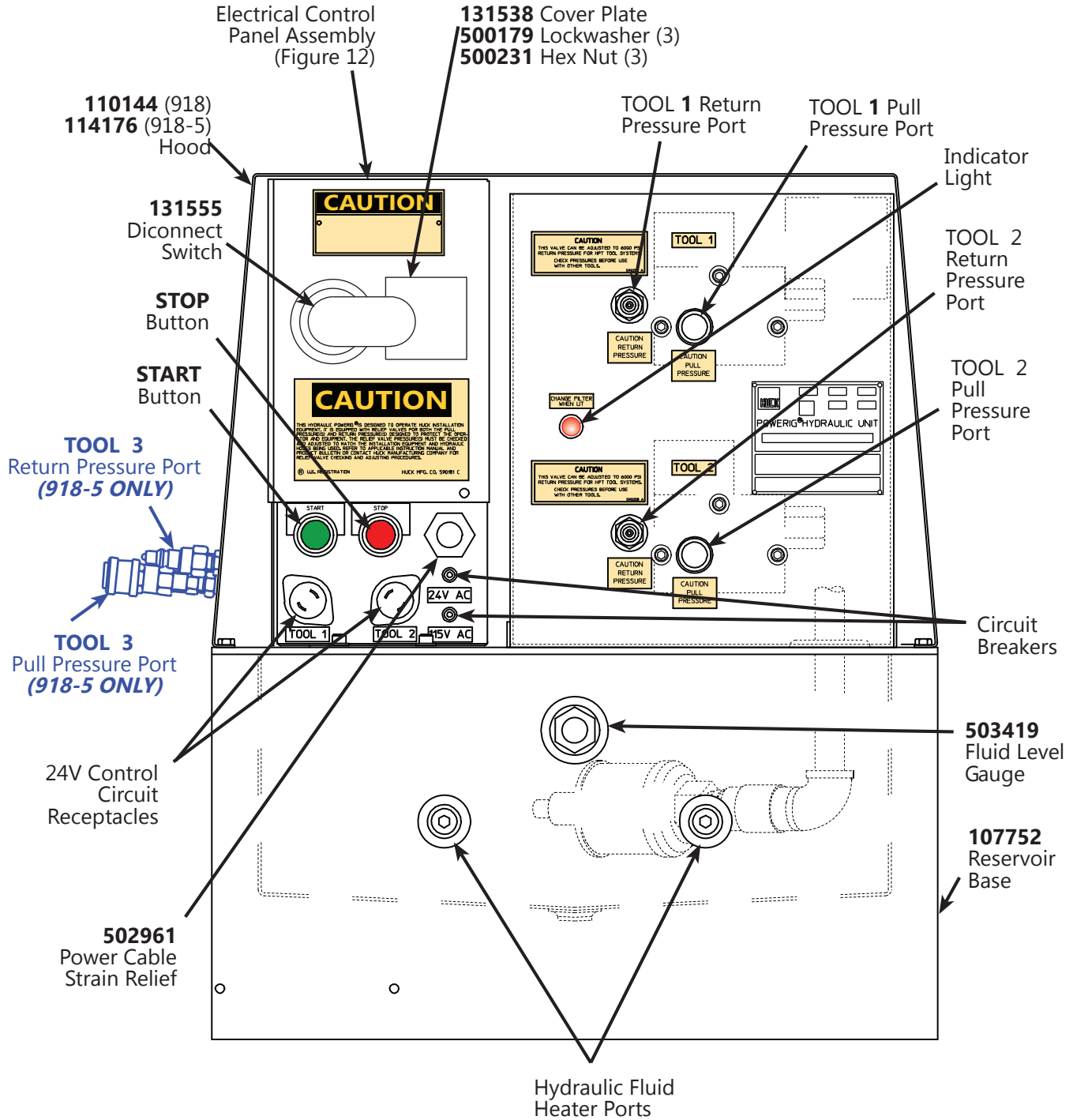

**Models 918 and 918-5
Front View**



Top View with Cover Removed

Figure 2

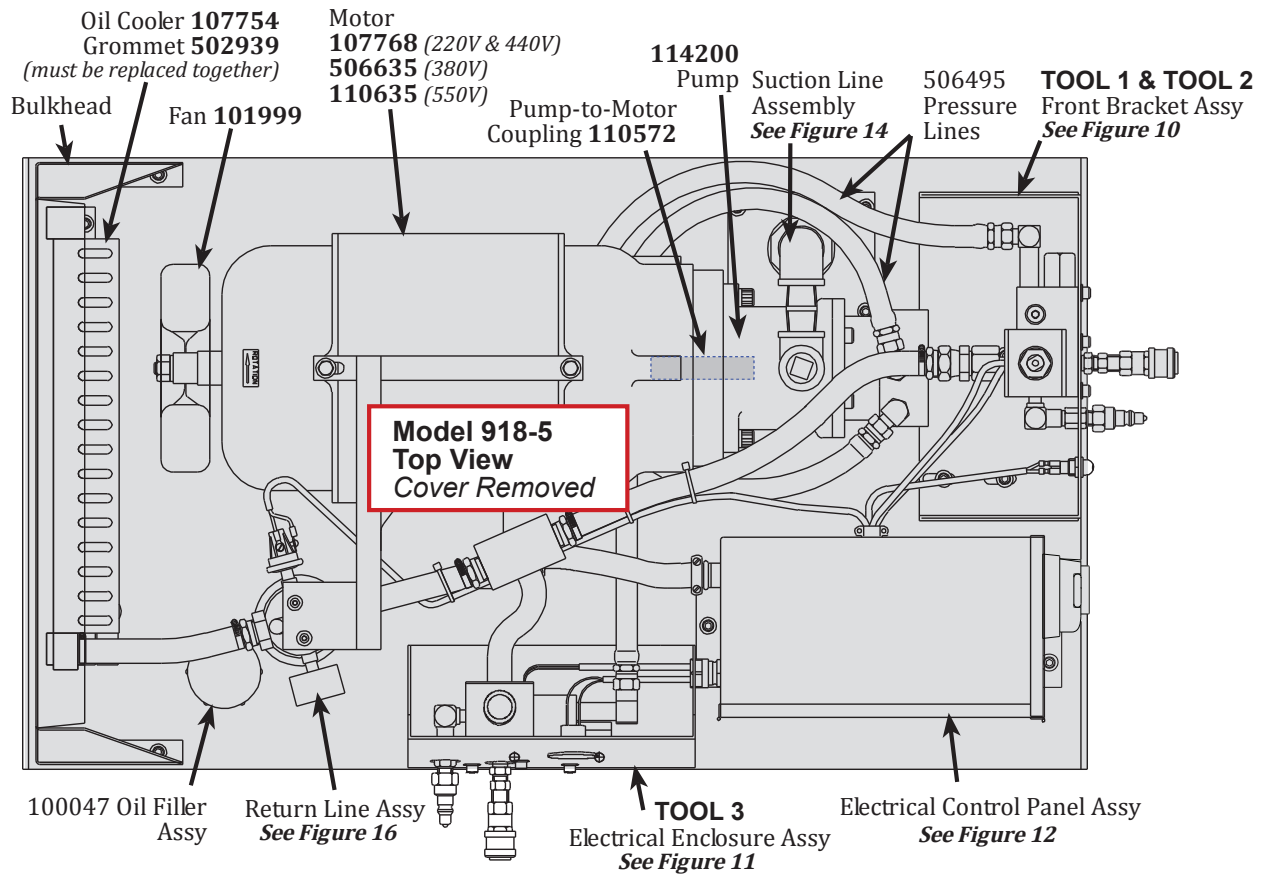
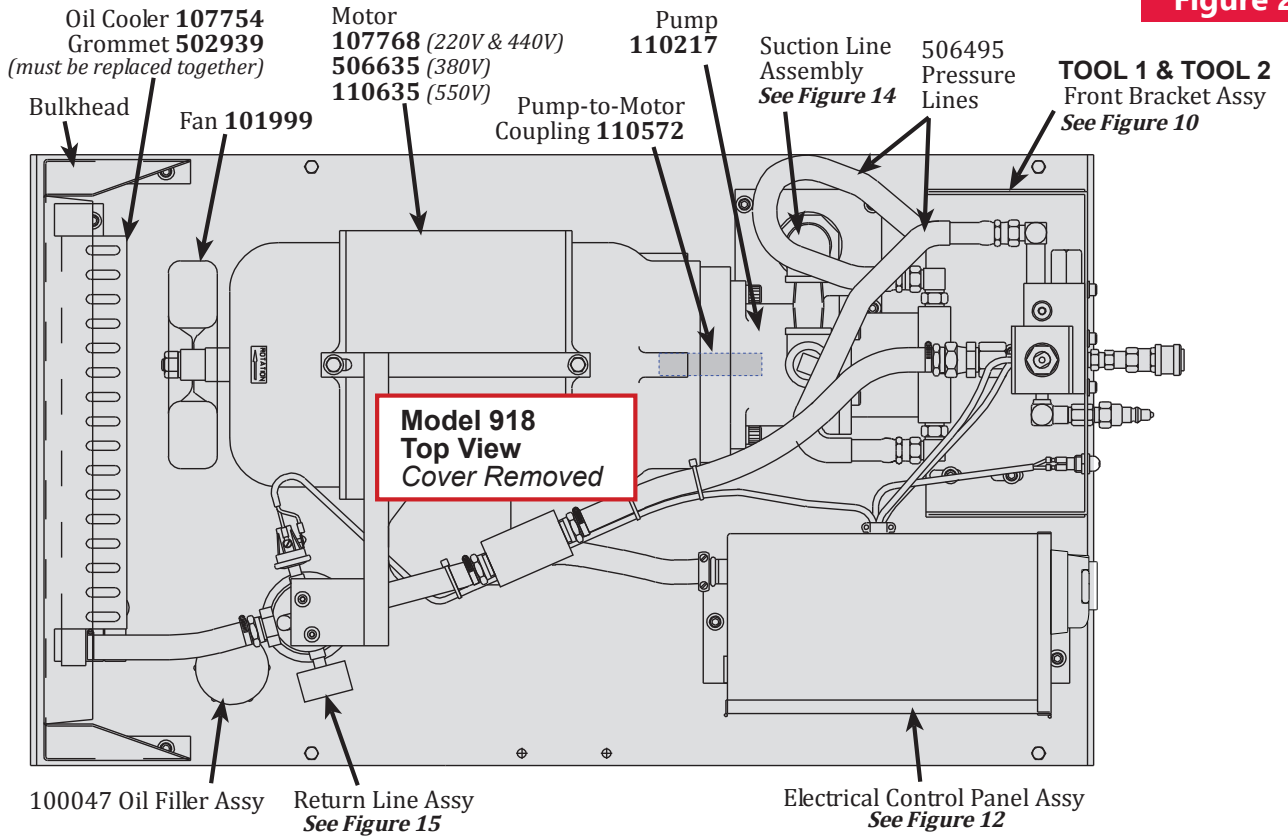



918 & 918-5 Electrical Schematic

Figure 3

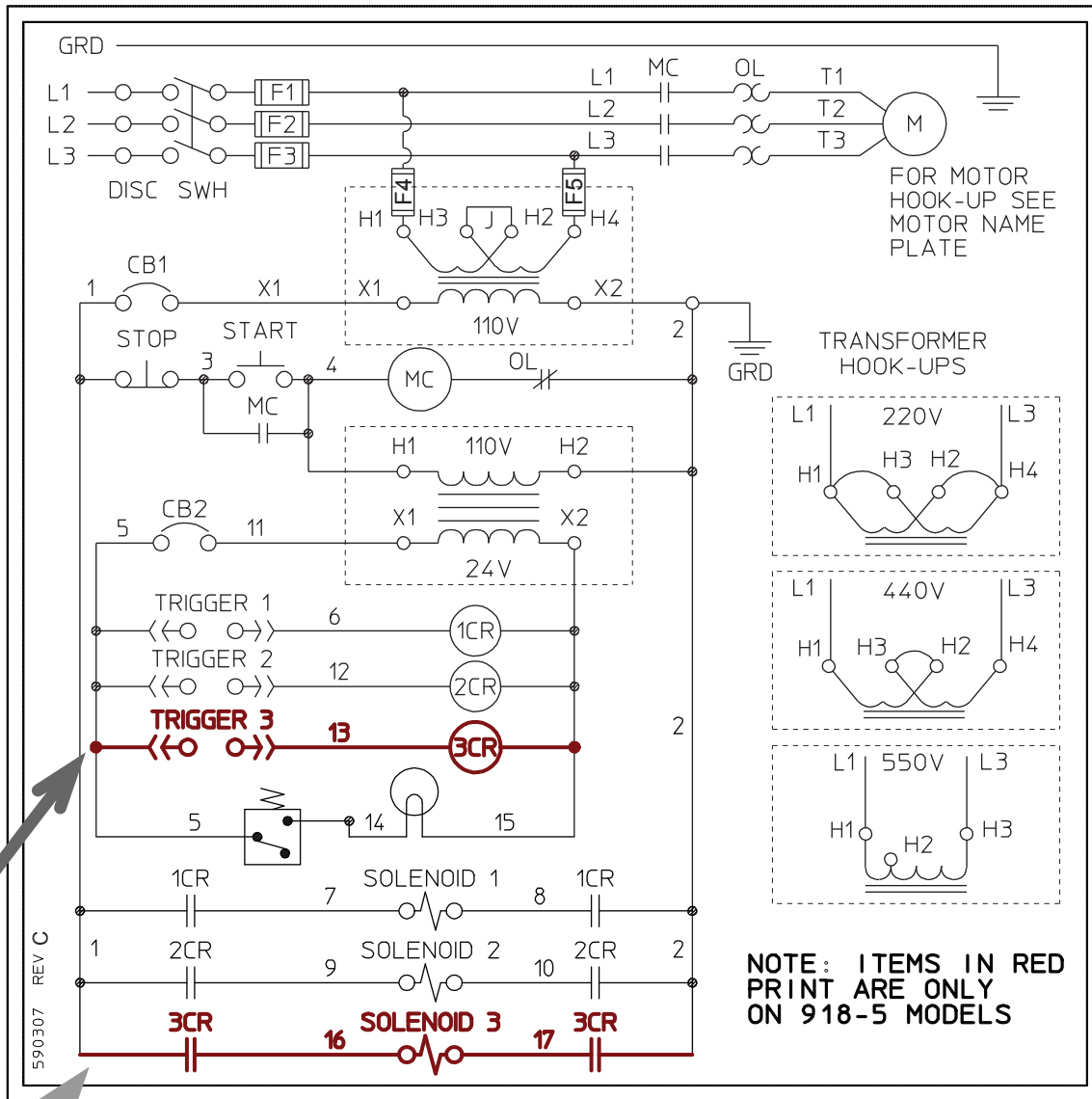

NOTE: The graphics identified below appear in RED printing on the schematic.





918-380 & 918-5/380 Electrical Schematic

Figure 4

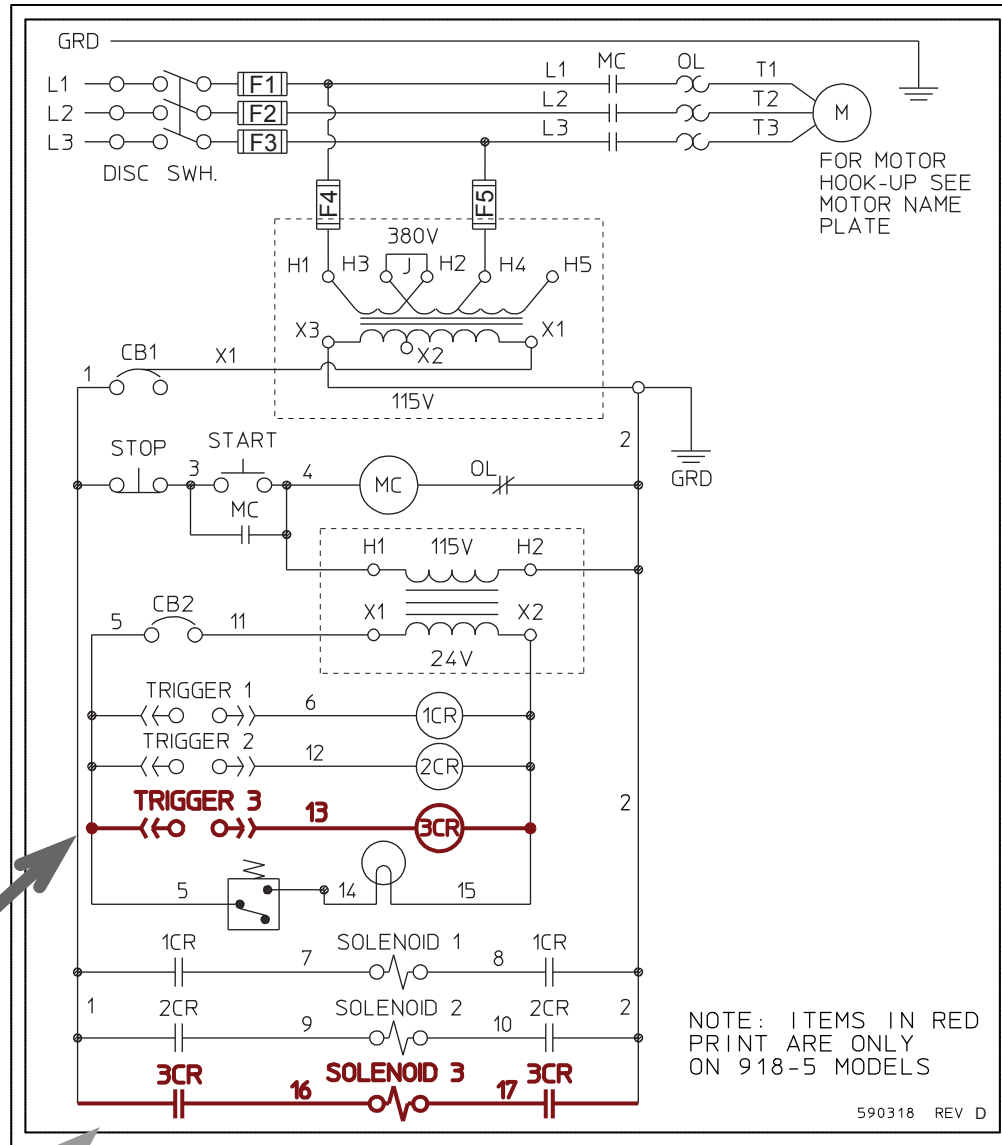

NOTE: The graphics identified below appear in RED printing on the schematic.





918 & 918-5 Hydraulic Diagram

Figure 5

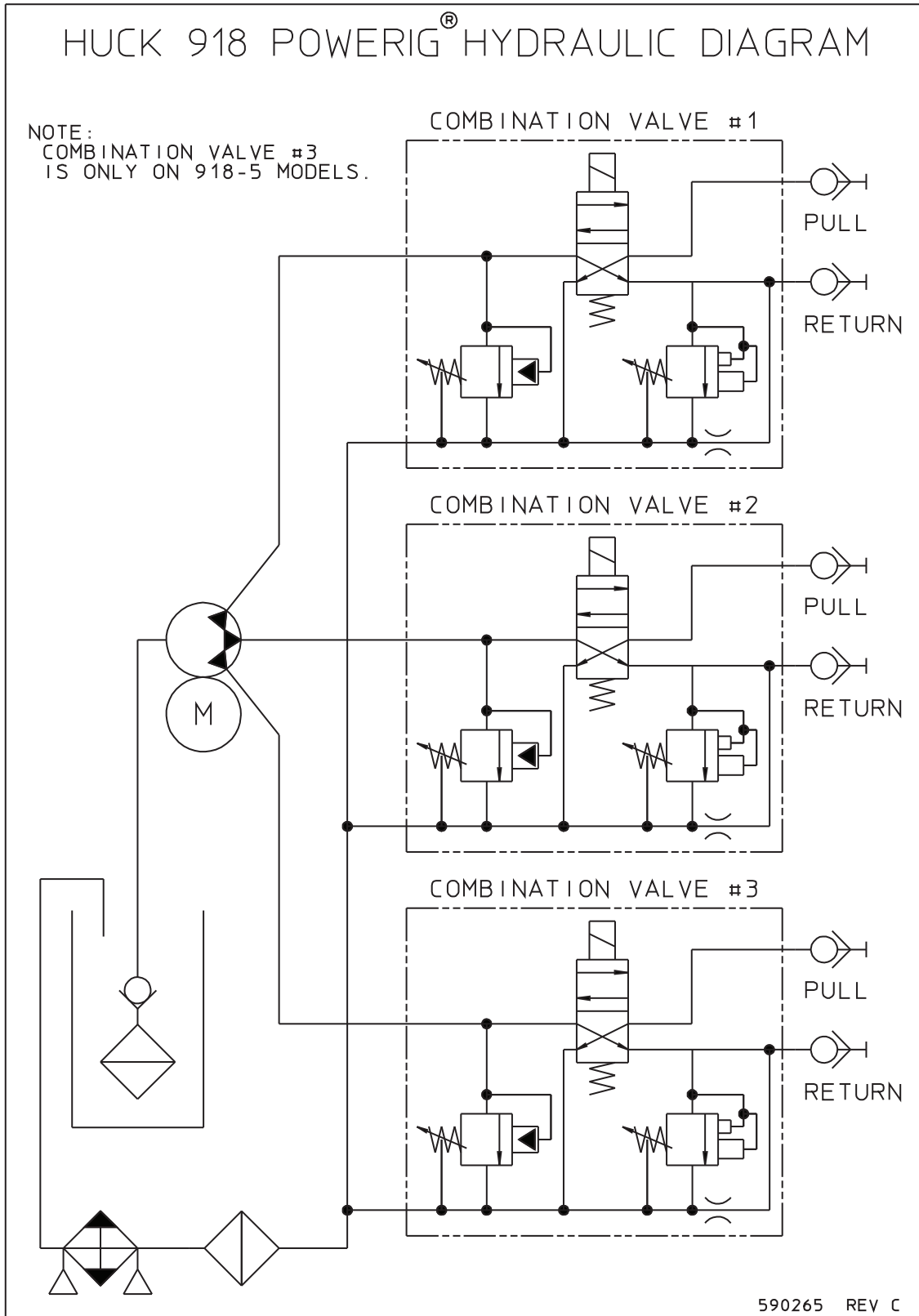



Typical Hose and Control Cord Hook-up

Figure 6

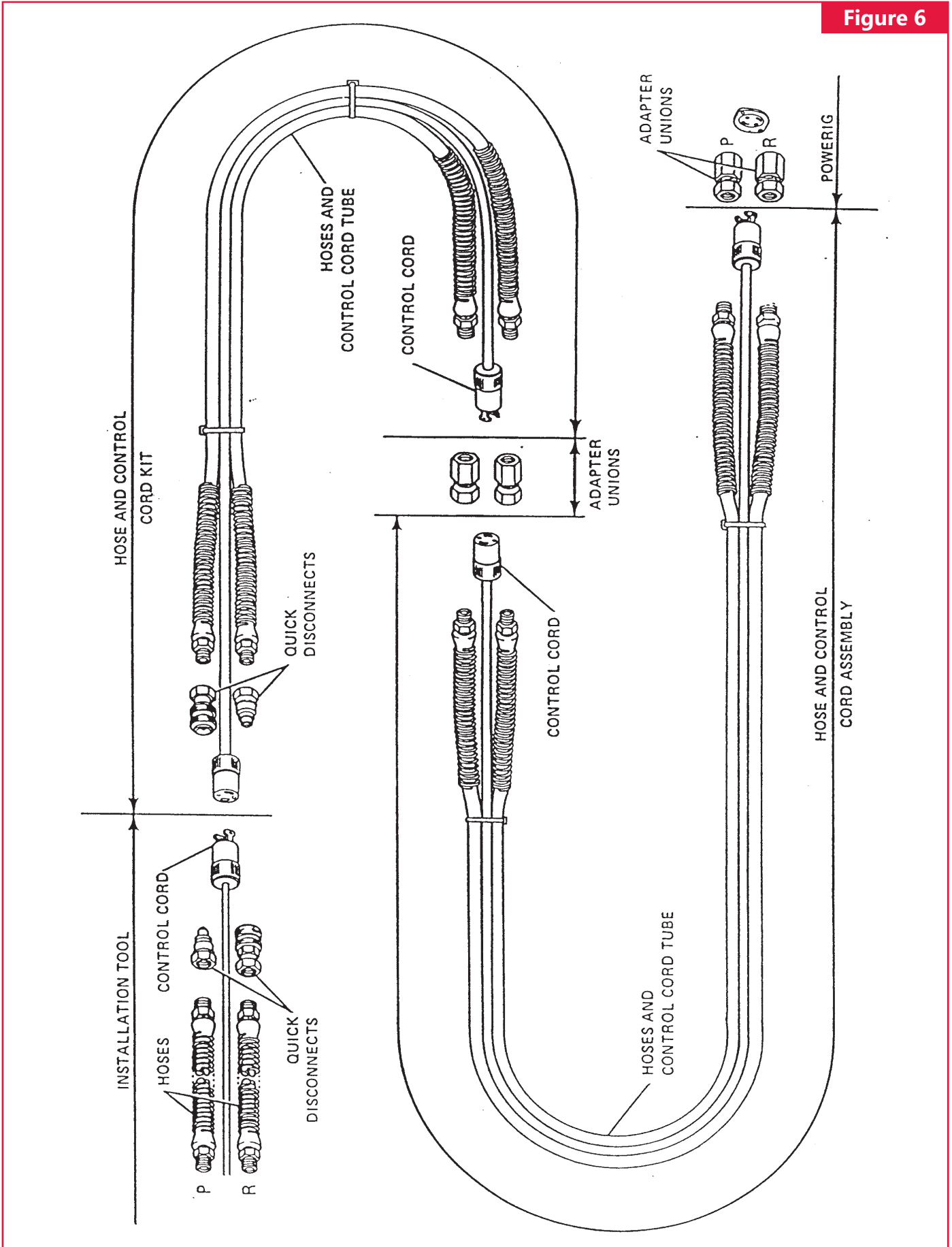



120073 Combination Valve Service Kit

Figure 7

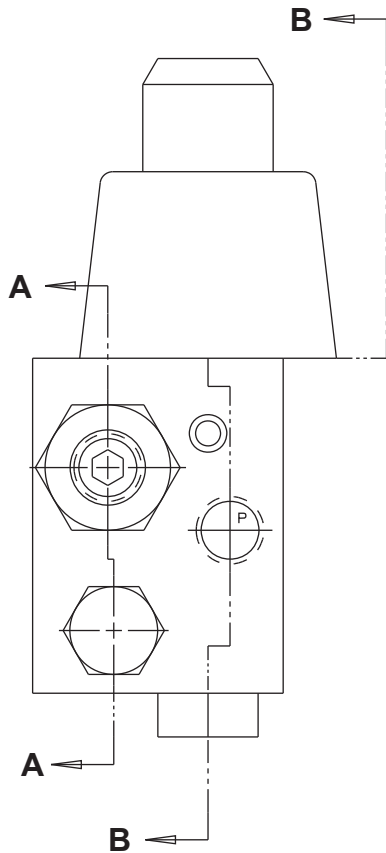

Used on Combination Valve, P/N 119740

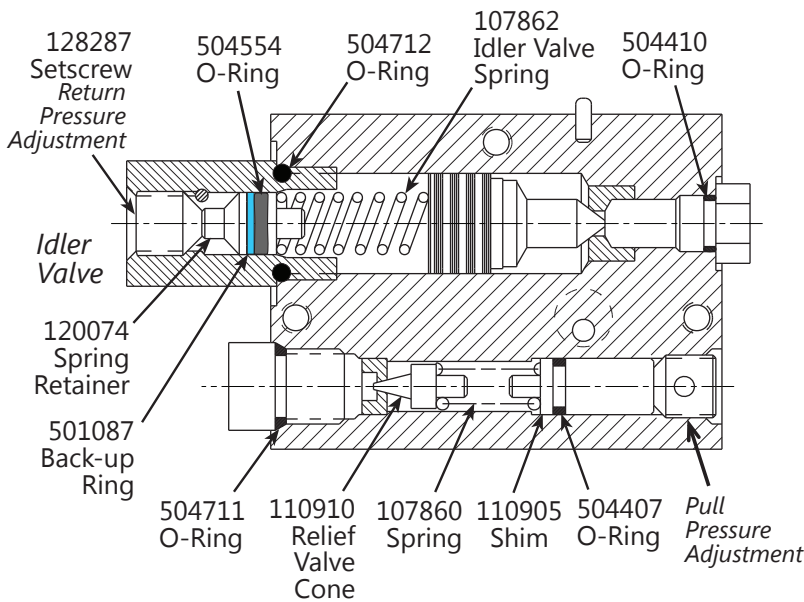

Section A-A
Idler Valve with Screw Adjustment

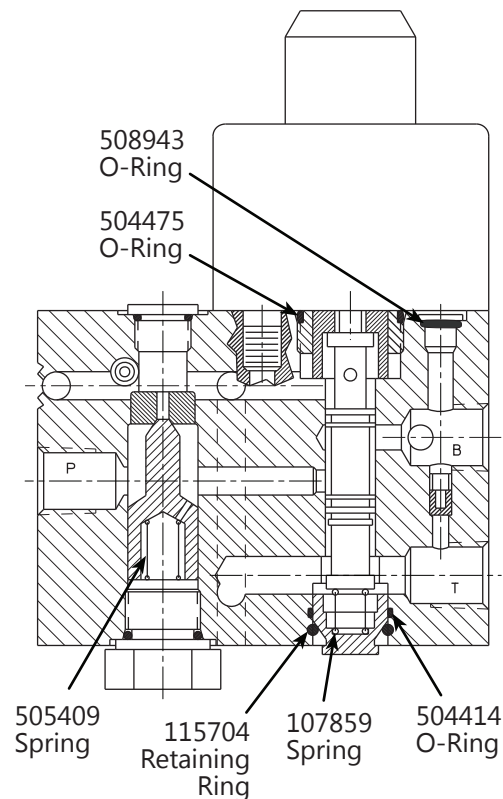

Section B-B
Screw Adjustment for Relief Valve



Hydraulic Pumps

For parts identification, see Figures 8 & 9 on the following pages.

The hydraulic pumps that are used on POWERIG® Hydraulic Unit models **918-2** and **918-3** are similar, except for the covers. The 918-2 pump cover has **two** outlets; the 918-3 pump cover has **three** outlets. For major overhaul, return pumps to the address shown on the inside back cover of this manual. These pumps will be returned to the manufacturer for overhaul and test, and will be returned with a new warranty. Minor servicing (clearing and replacing perishable and high-wear components) can be done if replacement parts (shown in Figure 8) are available. An extra pump for each POWERIG should be kept on hand.

TO REMOVE PUMP FOR OVERHAUL



CAUTION: Pumps must be primed after overhaul. See First-time Start-up. Check output pressures. See CHECKING & ADJUSTING OUTPUT PRESSURES.

For parts identification, see Figures 1, 2, 8, & 9.

1. Disconnect the electrical power supply from POWERIG and remove the hood.
2. Disconnect the solenoid wires in the electrical panel or remove the solenoids from the combination valves.
3. Disconnect the pressure hoses from the combination valves.
4. Disconnect the return line hose.
5. Remove the six socket-head cap screws holding bracket and combination valves. Lift bracket and valves, and set them aside.
6. Loosen the pipe coupling in suction-line assembly. See Figure 14, Item 6.
7. Remove two socket-head cap screws holding the pump to the motor.
8. Support weight of pump and slide out of motor housing.
9. Pump to motor coupling (P/N **110572**) comes out with the pump. Remove the coupling only if necessary.
10. Remove six socket-head cap screws (Figure 8, Item 7) to remove the cover when replacing O-rings, seats, balls, or springs. (If this is the only service being performed, omit steps 5, 6, 7, 8, and 9).
11. Remove the six socket-head screws (Figure 8, Item 6) to remove the barrel for replacement of O-ring, piston assemblies, or springs. (If this is the only service being performed, omit steps 5, 6, 7, 8, and 9).
12. A worn shaft seal can be removed using a pointed rod.
13. Use the Pump Seal Kit listed in **KITS & ACCESSORIES**.
14. Smear LUBRIPLATE® 130-AA (Huck P/N **502723**), or hydraulic fluid, on O-rings when reassembling.
15. Tighten socket-head screws (Figure 8, Items 6 & 7) to 30–35 ft.-lbs. torque.
16. If pump to motor coupling was removed, reassemble with coupling positioned 5/16" - 3/8" from pump flange.
17. Reassemble pump to motor. Tighten two socket-head screws to 90 ft.-lbs. torque if plated and 120 ft.-lbs. if unplated.
18. Reassemble solenoids, pressure hoses, return hose, and suction line. Use Threadmate® thread compound (P/N **508517**) on pipe threads of fittings and hoses.



Hydraulic Pumps (continued)

POWERIG	PUMP NO.	TYPE
918, all voltages	110217	2-Port
918-5, all voltages	114200	3-Port

Figure 8

Exploded View of Split Flow Hydraulic Pump

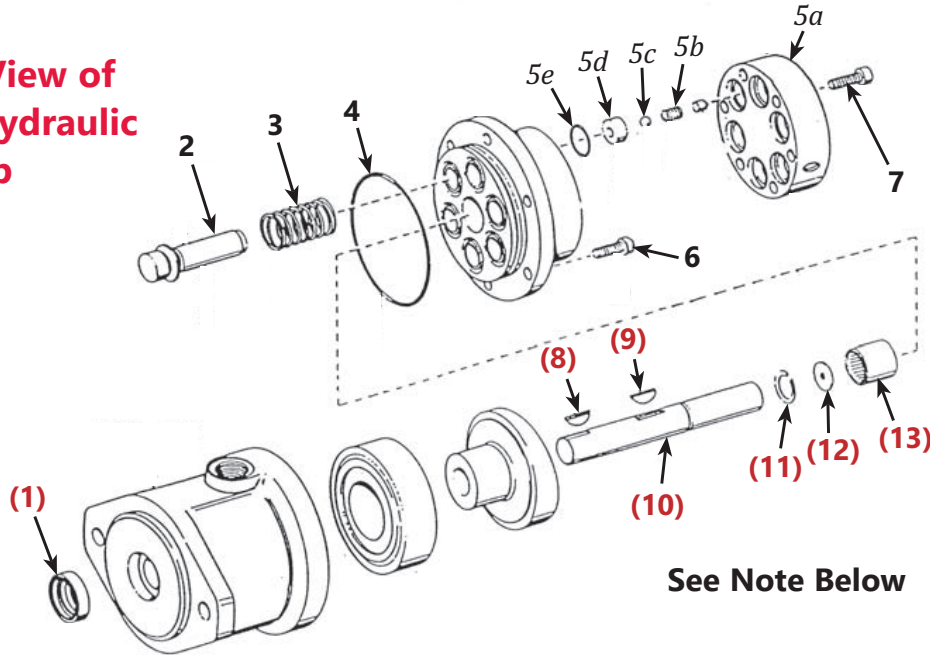

See Note Below

ITEM	918	918-5	DESCRIPTION	QTY
(1)	110931		Shaft Seal	1
2	109404		Piston Assembly	6
3	109405		Piston Return Spring	6
4	504649		O-ring	1
5	110509	114195	Cover & Pin Assembly	1
5a	109615	114199	Cover	1
5b	109407	109407	Spring	6
5c	109413	109413	Ball	6
5d	109406	109406	Seat	6
5e	504617	504617	O-ring	6
6	500090		Socket Head Screw 1"	6
7	500095		Socket Head Screw 2.25"	6
(8)	507597		Front Woodruff Key	1
(9)	507598		Middle Woodruff Key	1
(10)	122464		Shaft	1
(11)	507601		Pump Shaft Retaining Ring	1
(12)	122466		Thrust Washer	1
(13)	507599		Needle Bearing	1

Pump and Coupling

Figure 9

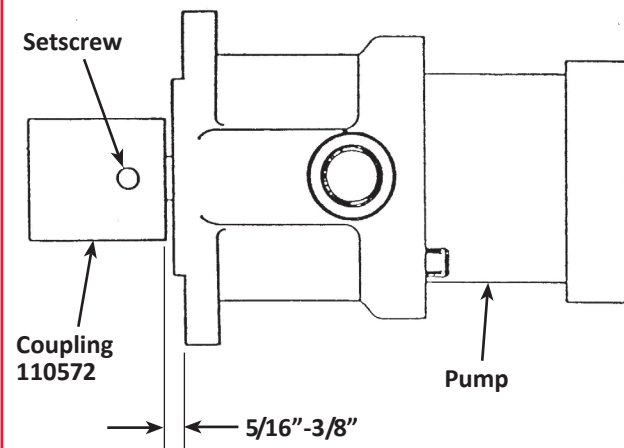

NOTE:
Numbers indicated by **(PARENTHESIS)** are included in Pump Shaft Kit, part number 122463.



Front Bracket Assembly

Figure 10

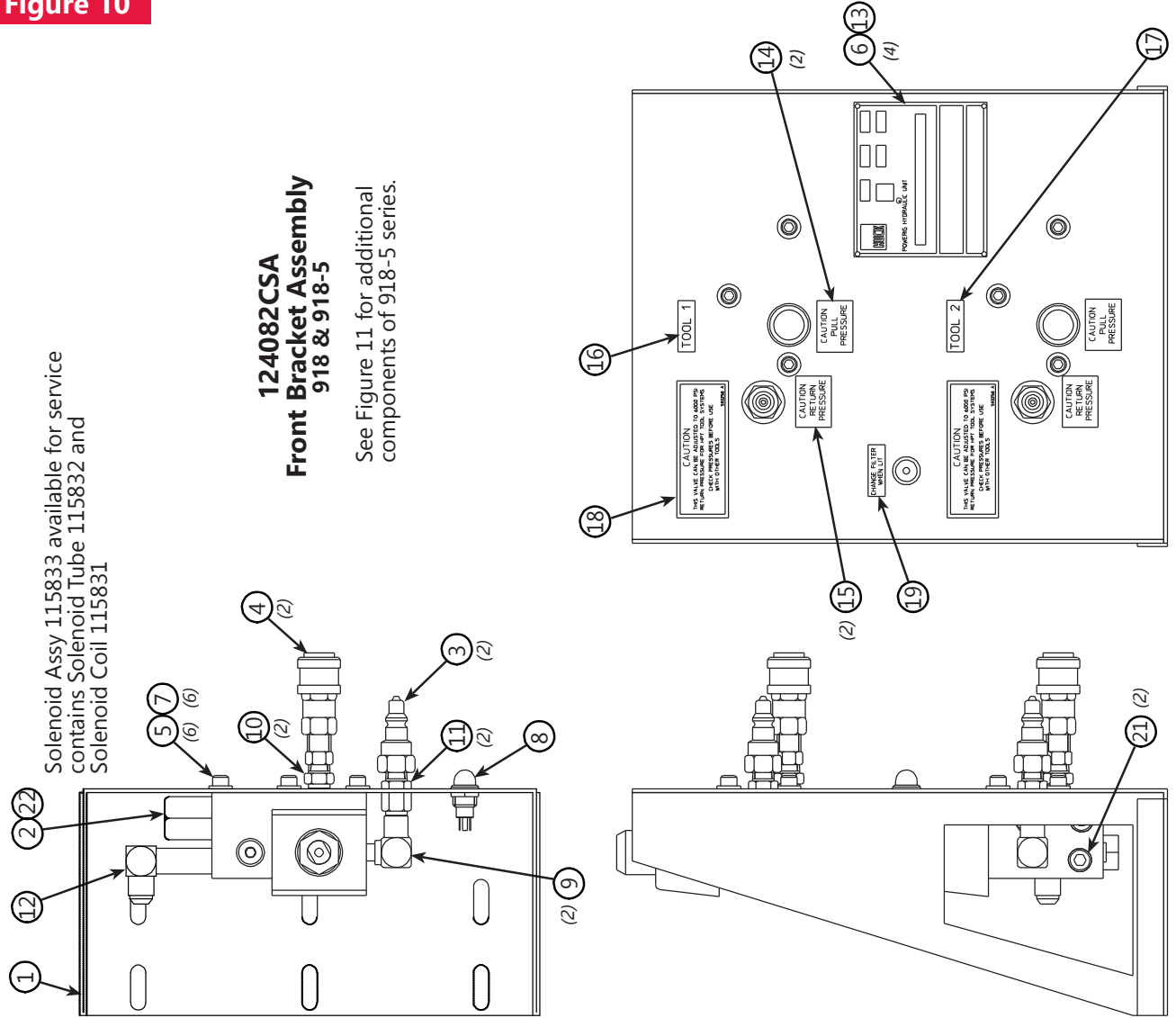

Part No.	Qty.	Description	Item
504275	3'	Fiberglass Sleeving	22
503706	2	Pipe Plug	21
590265	1	Hydraulic Diagram Sticker	20
590260	1	Change Filter Sticker	19
590258	2	Caution Sticker (ref)	18
590136	2	TOOL 2 Sticker	17
590135	2	TOOL 1 Sticker	16
590133	2	Return Pressure Sticker	15
590132	2	Pull Pressure Sticker	14
590012CSA	1	Nameplate	13
504058	2	Elbow	12
504057	2	Hex Nipple	11
503683	2	Hex Nipple	10
503680	2	Street Elbow	9
131371	1	Indicator Light	8
500170	6	Flat Washer	7
502992	4	Drive Screw	6
501236	6	Socket Head Screw	5
110439	2	Coupler Body	4
110438	2	Coupler Nipple	3
119740	2	Combination Valve	2
113922	1	Front Bracket	1

124082CSA_revC

124082CSA Front Bracket Assembly 918 & 918-5

See Figure 11 for additional components of 918-5 series.

Solenoid Assy 115833 available for service contains Solenoid Tube 115832 and Solenoid Coil 115831



Electrical Enclosure Assembly 918-5 series

Figure 11

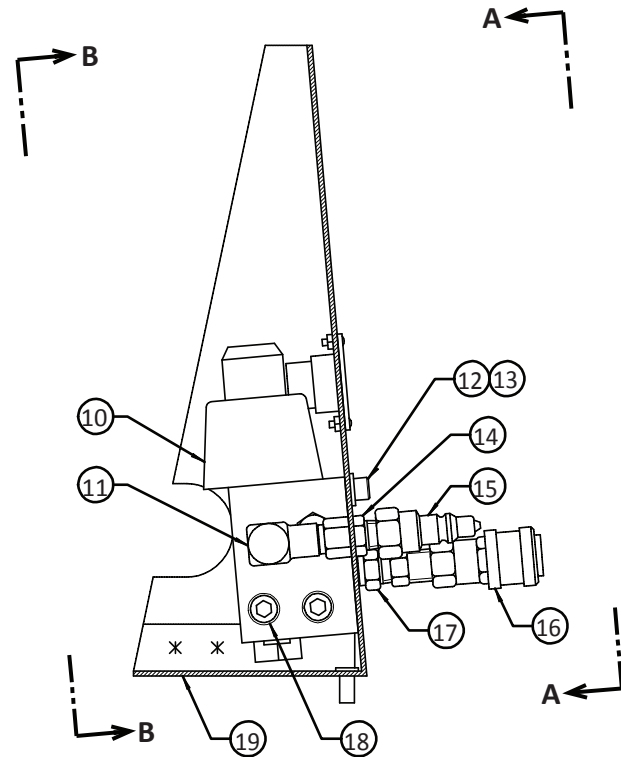
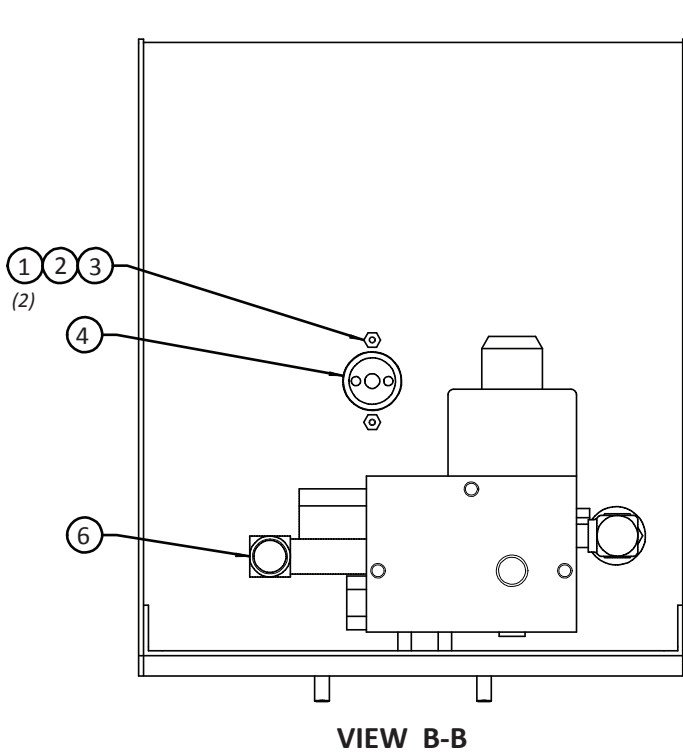

Solenoid Assy 115833 available for service contains Solenoid Tube 115832 and Solenoid Coil 115831

PART NO	QTY	DESCRIPTION	ITEM
123521	1	MOUNTING BRACKET .3-TOOL	19
503706	1	PIPE PLUG-FLUSH 3/8 NP	18
503683	1	NIPPLE,HEX .38 NPTF X 1.69	17
110439	1	BODY-HYD COUPLER	16
110438	1	NIPPLE-HYD COUPLER	15
504057	1	NIPPLE,HEX .38 NPTF X 2.25	14
500170	3	WASHER-SAE FLAT 31 ZP	13
501236	3	SCR SOC 31-18 X .50 LW ZP	12
503680	1	ELBOW,STREET	11
119739	1	VALVE-COMBINATION	10
590132	1	STICKER-PULL PRESSURE	9
590133	1	STICKER-RETURN PRESSURE	8
590250	1	STICKER-TOOL 3	7
504058	1	ELBOW 1-E#849LL-FS-08X06	6
590258	1	STICKER-CAUTION	5
110685	1	BASE FEMALE	4
500691	2	WASHER-LOCK INT TEETH #06	3
500400	2	MSCR RND #06-32 X 38 ZP	2
500212	2	NUT HEX #06-32 ZP	1
PART NO	QTY	DESCRIPTION	ITEM

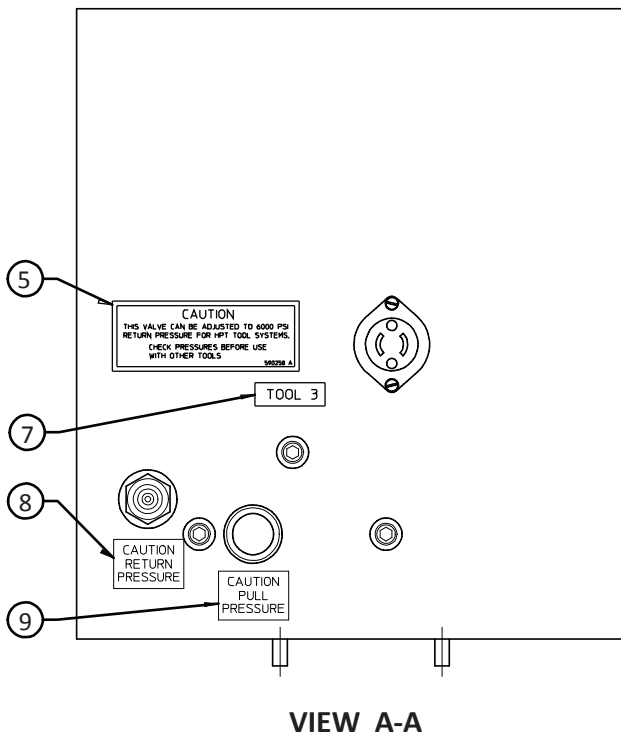

123526 - Electrical Enclosure Assembly 918-5, Tool 3



Electrical Control Panel Assembly

Figure 12

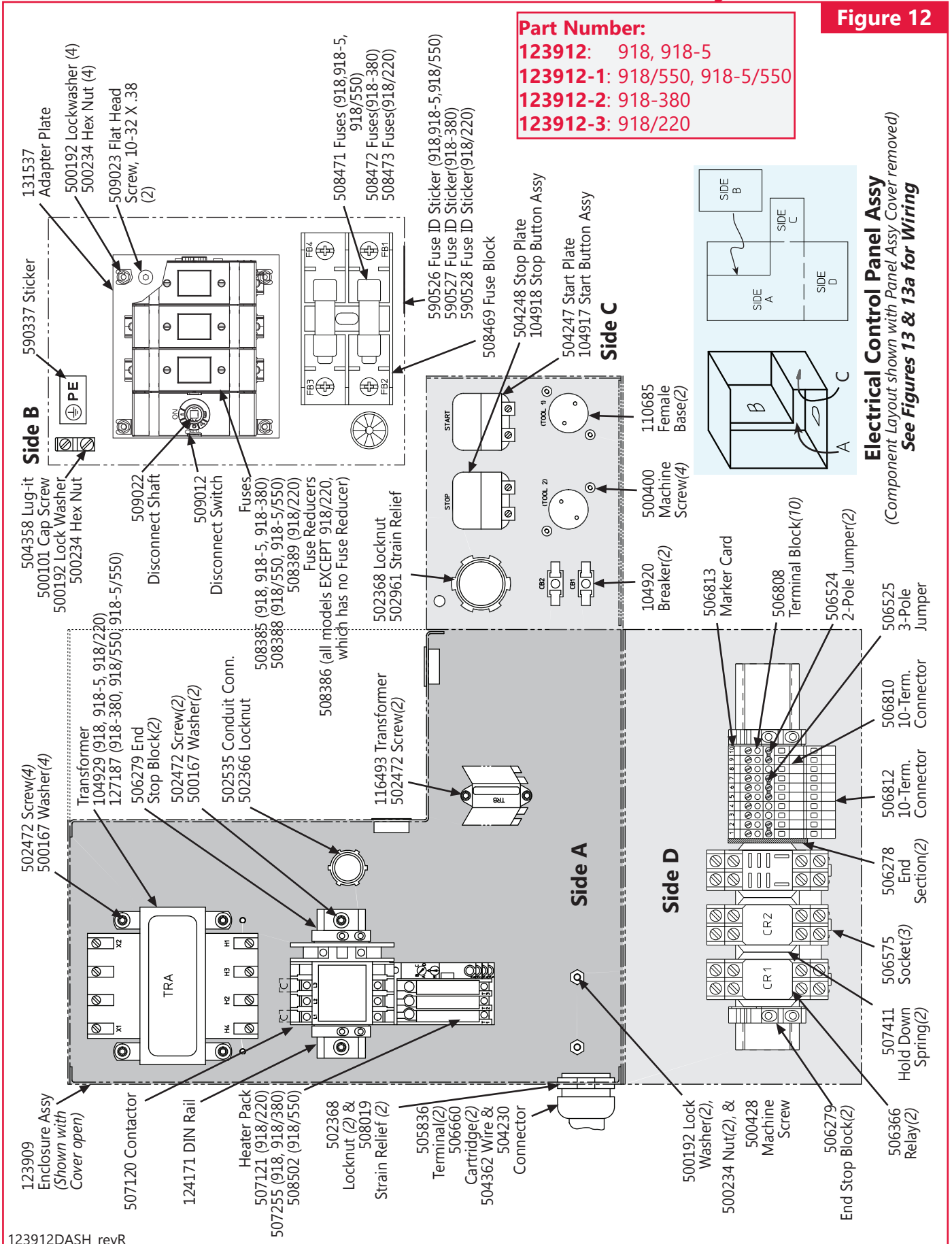



Electrical Control Panel Wiring

Figure 13

(Reference Figures 12 & 13a for layout)

NOTES:

1. Some components are shown disproportionately larger for clarity of wiring.
2. For wiring of other voltages, see Figure 13a on the next page.
3. Installed in the Contact Overload Block for 440V are Heaters 507255 (Dial set at "A"), for 550V are Heaters 508502 (Dial Set at "C"), for 380V are Heaters 507255 (Dial set at "B"), and for 220V are Heaters 507121 (Dial set at "B").

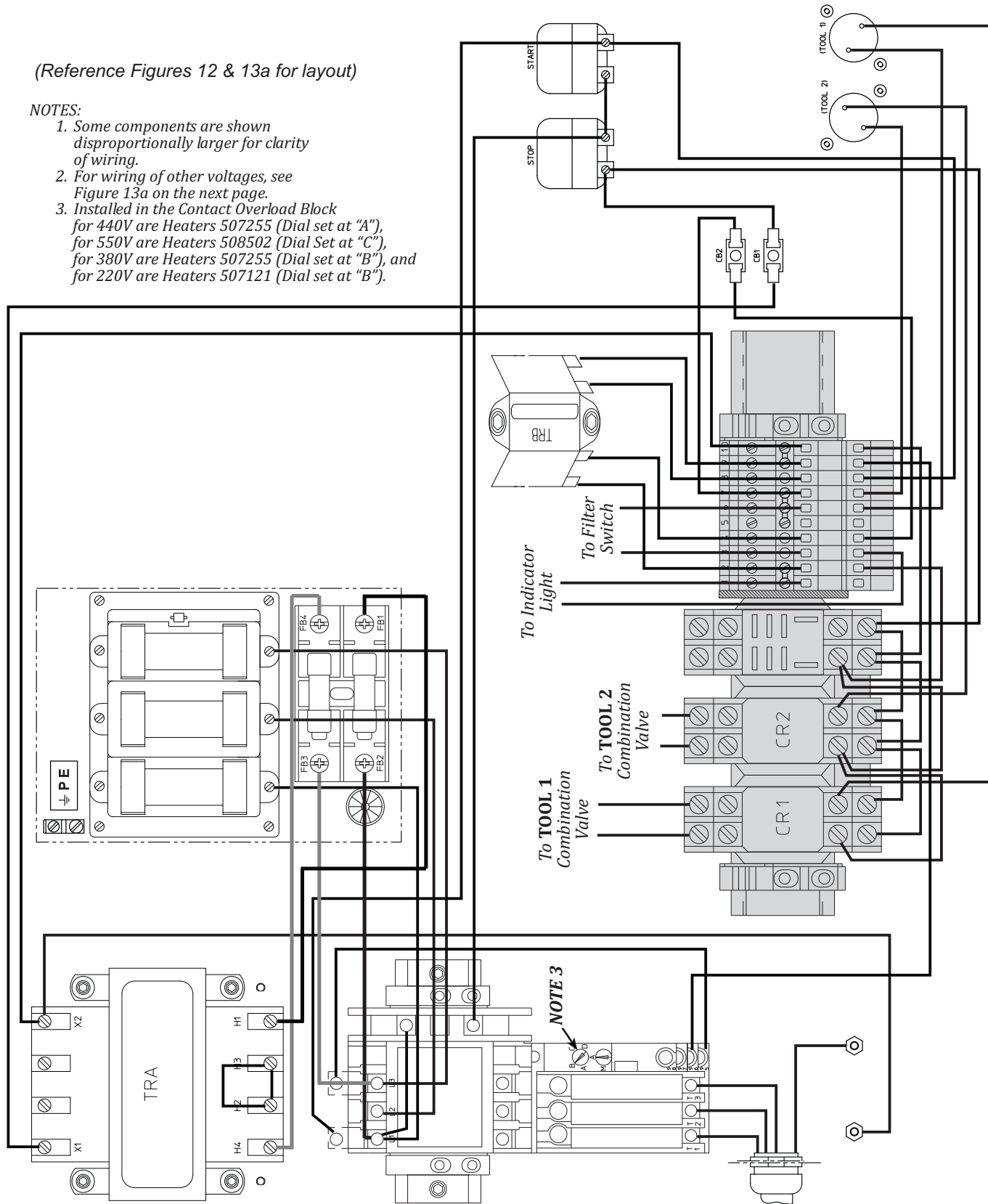



Electrical Control Panel Alternate Wiring

Figure 13a

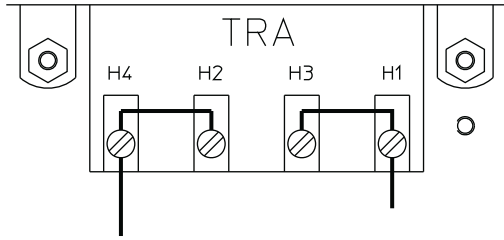

220V Hook-up

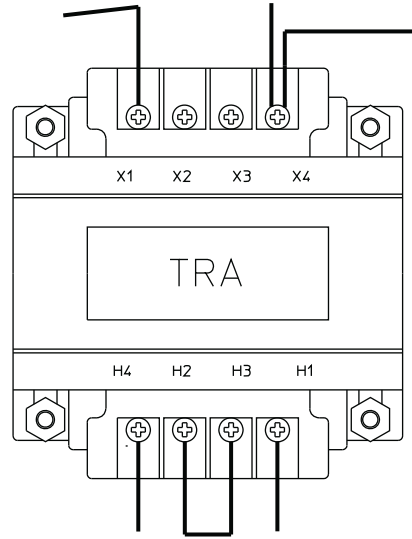

380V Hook-up

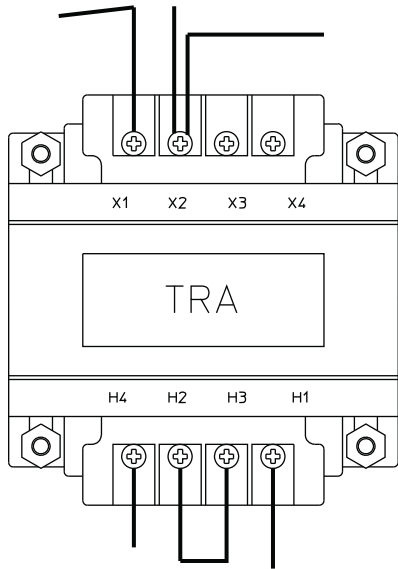

550V Hook-up

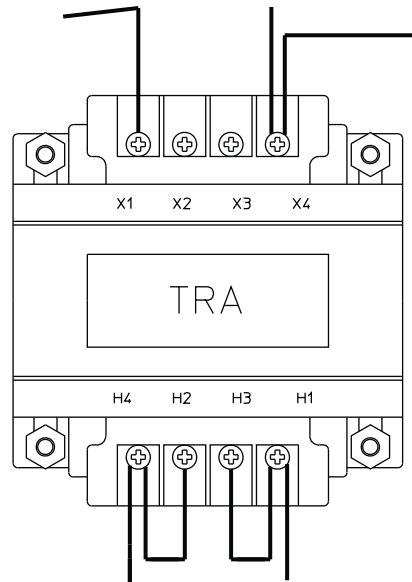

190V Hook-up



110135 Suction Line Assembly 918 & 918-5

Figure 14

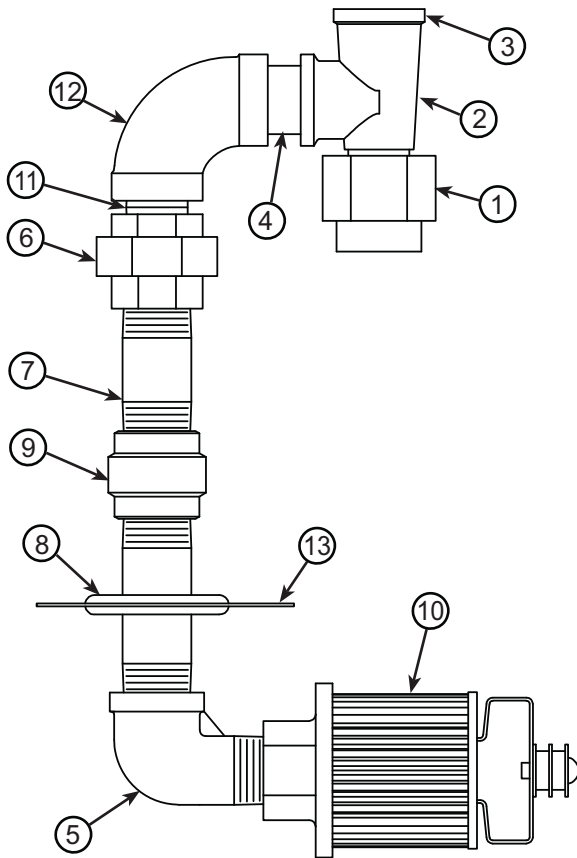

507461	1	Pipe Nipple	14
106561	1	Suction Line Plate	13
503744	1	Elbow	12
505937	1	Pipe Nipple	11
106540	1	Strainer	10
503894	1	Check Valve	9
503745	1	Grommet	8
503743	1	Pipe Nipple	7
506496	1	Pipe Coupling	6
503741	1	Street Elbow	5
503742	1	Pipe Nipple	4
505026	1	Pipe Plug	3
503746	1	Service Tee	2
503730	1	Str 1.31-12MUNC-1.00FNPT	1
Part No.	Qty.	Description	Item

110135_revK

119371 Return Line Assembly 918

Figure 15

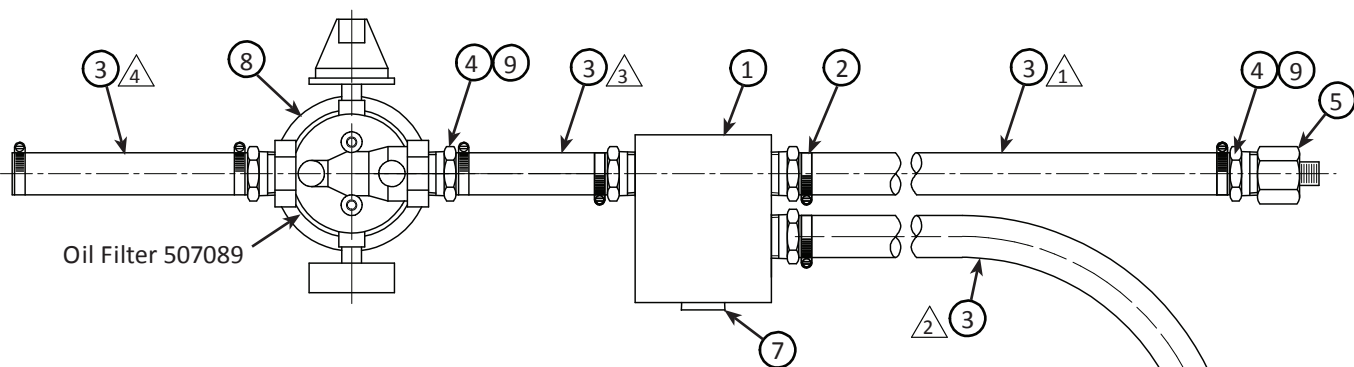

507561	8	Grommet, Hose Coupling	9
124850	1	Filter Assembly, Return Line	8
502377	1	Pipe Plug .75-14 Socket	7
506517	1	Elbow, 90°	6
506186	2	Straight SAE #6 - 3/4 NPT	5
502940	7	Hose Coupling 3/4 NPT	4
504154	58in.	Cotton Braid Hose	3
504361	8	Hose Clamp	2
123530	1	Return Line Manifold Block	1
Part No.	Qty.	Description	Item

Notes:

The hose lengths listed below are suggested lengths. Your hose length may vary slightly.

- ① Hose cut length = 19.00 inches
- ② Hose cut length = 21.00 inches
- ③ Hose cut length = 6.00 inches
- ④ Hose cut length = 6.75 inches

5 Apply Teflon sealant, Huck P/N 503237 on all tapered pipe connections.

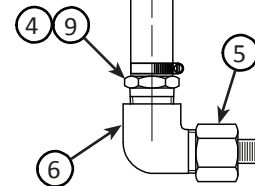

119371_revE



123529 Return Line Assembly 918-5

Figure 16

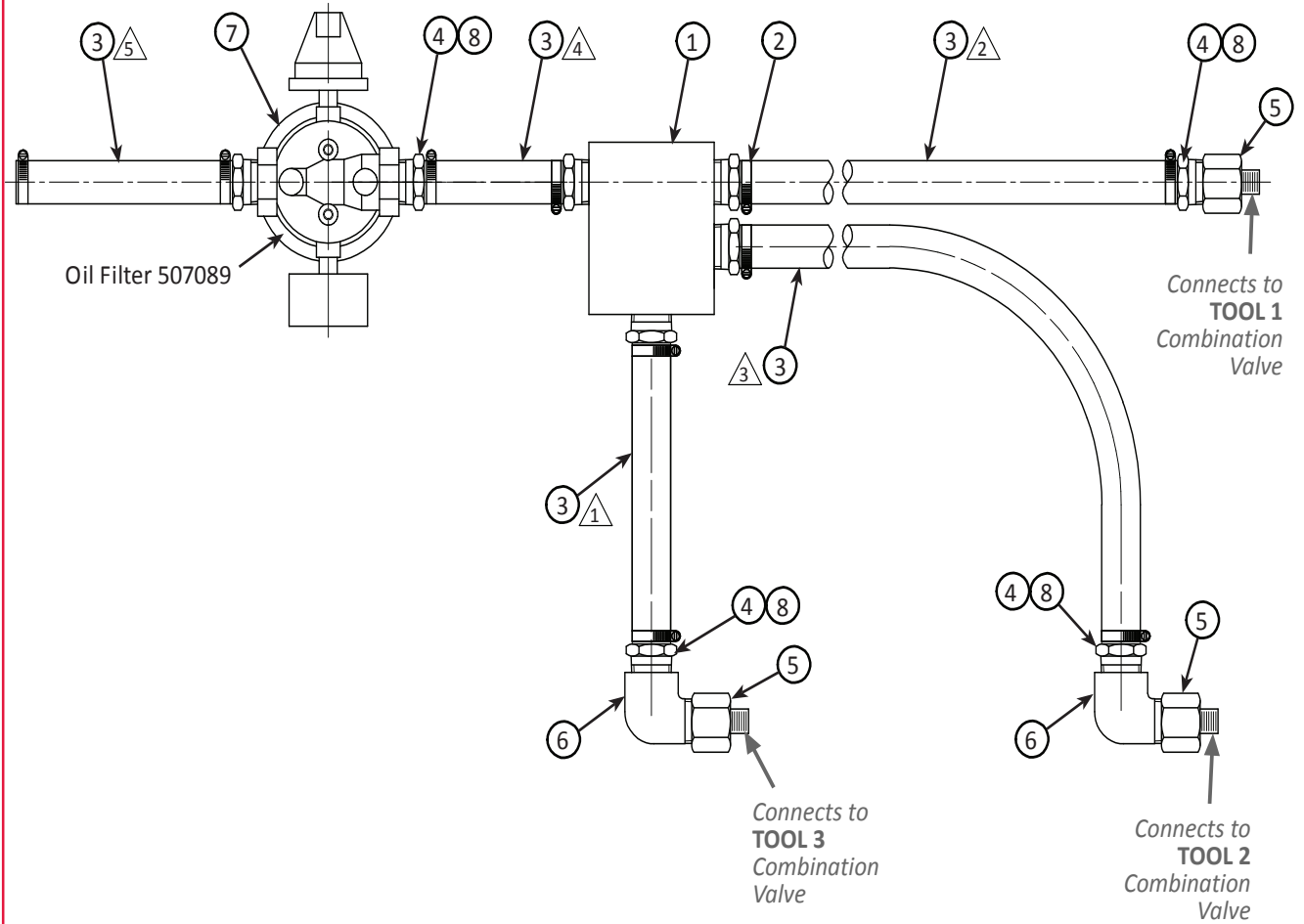

Note: The hose lengths listed below are suggested lengths. Your hose length may vary slightly.

- ① Hose cut length = 4.50 inches
- ② Hose cut length = 19.00 inches
- ③ Hose cut length = 21.00 inches
- ④ Hose cut length = 6.00 inches
- ⑤ Hose cut length = 6.75 inches

507561	9	Grommet, Hose Coupling	8
124850	1	Filter Assembly, Return Line	7
506517	2	Elbow, 90°	6
506186	3	Straight SAE #6 - 3/4 NPT	5
502940	9	Hose Coupling 3/4 NPT	4
504154	6 ft.	Cotton Braid Hose	3
504361	10	Hose Clamp	2
123530	1	Return Line Manifold Block	1
Part No.	Qty.	Description	Item

123529 - Return Line Assembly
918-5



Troubleshooting

Always check the simplest possible cause of a malfunction first. Review [PREPARATION FOR USE](#) and First-time Start-up. Check fuses, circuit breakers, control cord, connections, and hydraulic hose couplers. Where possible, substitute known good parts for suspected bad parts. Use the following troubleshooting information to aid in locating trouble and correcting it. Also, refer to the electrical and hydraulic schematics, and the wiring diagrams to trace defective circuits.

- 1. With Powerig® motor running, tool fails to operate when trigger is pressed:**
 - a. Loose or faulty connections in control cord.
 - b. Loose or faulty hydraulic hose couplings.
 - c. Defective tool trigger assembly.
 - d. Open 24 volt circuit breaker.
 - e. Defective relay or solenoid coil.
 - f. Hydraulic fluid viscosity too heavy to pick up prime; replace fluid.
 - g. Clogged strainer in reservoir.
 - h. Defective hydraulic pump; replace pump.
 - j. Defective directional valve assembly; replace assembly.
 - k. Installation tool not operating properly. (See tool instruction manual to troubleshoot tool.)
- 2. Tool does not return on release of trigger:**
 - a. Defective relay or solenoid coil.
 - b. Defective directional valve. Clean and replace spring.
 - c. Installation tool not operating properly. (See tool instruction manual to troubleshoot tool.)
- 3. Pump cavitating (noisy during entire installation cycle):**
 - a. Low hydraulic fluid level in reservoir.
 - b. Clogged strainer in reservoir.
 - c. Hydraulic fluid viscosity too heavy to pickup prime; replace fluid.
- 4. Tool operation slow but entire cycle does occur:**
 - a. Pump cavitating. See 3.
 - b. Hydraulic fluid viscosity too thin. Do not operate if over 150-degrees F (65-degrees C).
 - c. Worn seals in combination valve; replace seals with kit.
 - d. Worn pump seals, seats, etc. Replace seals, etc. or entire pump if necessary.
 - e. Worn directional valve or relief valves. Use Gauge T-124833CE to check output pressure; replace valve if necessary.
- 5. Solenoid coil heats up:**
 - a. Low voltage. Check and correct.
 - b. Wrong solenoid coil. Replace coil (50 Hz or 60 Hz)



Limited Warranties

Limited Lifetime Warranty on BobTail® Tools:

Huck International, Inc. warrants to the original purchaser that its BobTail® installation tools manufactured after 12/1/2016 shall be free from defects in materials and workmanship for its **useful lifetime**. This warranty does not cover special order / non-standard products, or part failure due to normal wear, tool abuse or misapplication, or user non-compliance with the service requirements and conditions detailed in the product literature.

Two Year Limited Warranty on Installation Tools:

Huck International, Inc. warrants that its installation tools and Powerig® hydraulic power sources manufactured after December 1, 2016 shall be free from defects in materials and workmanship for a period of two years from date of purchase by the end user. This warranty does not cover special order / non-standard products, or part failure due to normal wear, tool abuse or misapplication, or user non-compliance with the service requirements and conditions detailed in the product literature.

90 Day Limited Warranty on Nose Assemblies and Accessories:

Huck International, Inc. warrants that its nose assemblies and accessories shall be free from defects in materials and workmanship for a period of 90 days from date of purchase by the end user. This warranty does not cover special clearance noses, or special order / non-standard product, or part failure due to normal wear, abuse or misapplication, or user non-compliance with the service requirements and conditions detailed in the product literature.

Useful lifetime is defined as the period over which the product is expected to last physically, up to the point when replacement is required due to either normal in-service wear, or as part of a complete overhaul. Determination is made on a case-by case basis upon return of parts to Huck International, Inc. for evaluation.

Tooling, Part(s) and Other Items not manufactured by Huck:

HUCK makes no warranty with respect to the tooling, part(s), or other items manufactured by third parties. HUCK expressly disclaims any warranty expressed or implied, as to the condition, design, operation, merchantability, or fitness for use of any tool, part(s), or other items thereof not manufactured by HUCK. HUCK shall not be liable for any loss or damage, directly or indirectly, arising from the use of such tooling, part(s), or other items or breach of warranty or for any claim for incidental or consequential damages.

Huck shall not be liable for any loss or damage resulting from delays or non-fulfillment of orders owing to strikes, fires, accidents, transportation companies or for any reason or reasons beyond the control of the Huck or its suppliers.

Huck Installation Equipment:

Huck International, Inc. reserves the right to make changes in specifications and design and to discontinue models without notice.

Huck Installation Equipment should be serviced by trained service technicians only.

Always give the serial number of the equipment when corresponding or ordering service parts.

Complete repair facilities are maintained by Huck International, Inc. Please contact one of the offices listed below.

Eastern

One Corporate Drive Kingston, New York 12401-0250
Telephone (845) 331-7300 FAX (845) 334-7333

Outside USA and Canada

Contact your nearest Huck International location (see reverse).

In addition to the above repair facilities, there are Authorized Tool Service Centers (ATSC's) located throughout the United States. These service centers offer repair services, spare parts, Service Parts Kits, Service Tool Kits and Nose Assemblies. Please contact your Huck Representative or the nearest Huck International location (see reverse) for the ATSC in your area.



**HOWMET
AEROSPACE**

Howmet Inc. (NYSE: ARNC) creates breakthrough products that shape industries. Working in close partnership with our customers, we solve complex engineering challenges to transform the way we fly, drive, build and power.

Through the ingenuity of our people and cutting-edge advanced manufacturing, we deliver these products at a quality and efficiency that ensures customer success and shareholder value.

	<p>© 2019 Huck International, Inc. Howmet Fastening Systems Kingston Operations</p>
--	----------------------------------------------------------------------------------------------------



Huck provides technical assistance regarding the use and application of Huck fasteners and tooling. **NOTICE:** The information contained in this publication is only for general guidance with regard to properties of the products shown and/or the means for selecting such products, and is not intended to create any warranty,

express, implied, or statutory; all warranties are contained only in Huck's written quotations, acknowledgments, and/or purchase orders. It is recommended that the user secure specific, up-to-date data and information regarding each application and/or use of such products.

Applifast.



251 Cree Crescent, Winnipeg, MB Canada R3J 3X4
Tel: 204 837 8361 • 1 800 563 1293
info@applifast.com



applifast.com