



Instruction Manual

256BT

Pneudraulic Installation Tool

Patent Pending



Table of Contents

Declaration of Conformity	2
Safety Instructions	3
Specifications	4
Principle of Operation	4
Attaching a Nose Assembly	4
Preparation for Use	5
Operating Instructions	5
Measuring Tool Stroke	6
Maintenance	6
Disassembly Procedure	7-8
Assembly Procedure	8-9
Fill and Bleed	10-11
Components Drawings	12-13
Troubleshooting	14
Kits and Accessories	14



**HOWMET
AEROSPACE**

Declaration of Conformity

Manufacturer:

Huck International, LLC, Industrial Products Group, 1 Corporate Drive, Kingston, NY, 12401, USA

Description of Machinery:

Models 24#, 25#, and 2047 family of hydraulic installation tools and specials based on their design (e.g. PR#####).

Relevant provisions complied with:

- Council Directive related to Machinery (2006/42/EC)
- Supply of Machinery (Safety) Regulations 2008
- British Standard related to hand held, non-electric power tools (ISO 11148-2:2011)

Representatives:

- UK: Paul Carson, Huck International, Ltd. Unit C Stafford Park 7, Telford Shropshire TF3 3BQ, England, United Kingdom
- EU: Lutz Baumann, Hildesheim Operations, Fairchild Fasteners Europe - VSD GmbH, Steven 3, 31135, Hildesheim, Germany

Authorized Signature/date:

I, the undersigned, do hereby declare that the equipment specified above conforms to the above Directive(s) and Standard(s).

Signature: _____

Full Name: Nicholas Gougoutris
 Position: Engineering Manager
 Location: Huck International, LLC d/b/a Howmet Fastening Systems
 Kingston, New York, USA
 Date: 11/02/2021 (November 2, 2021)



Declared dual number noise emission values in accordance with ISO 4871

A weighted sound power level, LWA: 91 dB (reference 1 pW) Uncertainty, KWA: 3 dB
A weighted emission sound pressure level at the work station, LpA: 80 dB (reference 20 µPa) Uncertainty, KpA: 3 dB
C-weighted peak emission sound pressure level, LpC, peak: 115 dB (reference 20 µPa) Uncertainty, KpC: 3 dB
Values determined according to noise test code ISO 3744. The sum of a measured noise emission value and its associated uncertainty represents an upper boundary of the range of values which is likely to occur in measurements.

Declared vibration emission values in accordance with EN 12096

Measured Vibrations emission value, a:	.63 m/s ²
Uncertainty, K:	.72 m/s ²
Values measured and determined according to ISO 28662-1, ISO 5349-2, and EN 1033	

Test data to support the above information is on file at:
 Howmet Fastening Systems, Kingston Operations, Kingston, NY, USA.



Safety Instructions

GLOSSARY OF TERMS AND SYMBOLS:

UK CE -Product complies with requirements set forth by the relevant UK and European directives.



-Read manual prior to using this equipment.



-Eye protection is required while using this equipment.



-Hearing protection is required while using this equipment.

Notes: are reminders of required procedures.

Bold, Italic type, and underline: emphasize a specific instruction.



WARNINGS: Must be understood to avoid severe personal injury.



CAUTIONS: Show conditions that will damage equipment or structure.

I. GENERAL SAFETY RULES:

1. A half hour long hands-on training session with qualified personnel is recommended before using Huck equipment.
2. Huck equipment must be maintained in a safe working condition at all times. Tools and hoses should be inspected at the beginning of each shift/day for damage or wear. Any repair should be done by a qualified repairman trained on Huck procedures.
3. For multiple hazards, read and understand the safety instructions before installing, operating, repairing, maintaining, changing accessories on, or working near the assembly power tool. Failure to do so can result in serious bodily injury.
4. Only qualified and trained operators should install, adjust or use the assembly power tool.
5. Do not modify this assembly power tool. This can reduce effectiveness of safety measures and increase operator risk.
6. Do not discard safety instructions; give them to the operator.
7. Do not use assembly power tool if it has been damaged.
8. Tools shall be inspected periodically to verify all ratings and markings required, and listed in the manual, are legibly marked on the tool. The employer/operator shall contact the manufacturer to obtain replacement marking labels when necessary. Refer to assembly drawing and parts list for replacement.
9. Tool is only to be used as stated in this manual. Any other use is prohibited.
10. Read MSDS Specifications before servicing the tool. MSDS specifications are available from the product manufacturer or your Huck representative.
11. Only genuine Huck parts shall be used for replacements or spares. Use of any other parts can result in tooling damage or personal injury.
12. Never remove any safety guards or pintail deflectors.
13. Never install a fastener in free air. Personal injury from fastener ejecting may occur.
14. Where applicable, always clear spent pintail out of nose assembly before installing the next fastener.
15. Check clearance between trigger and work piece to ensure there is no pinch point when tool is activated. Remote triggers are available for hydraulic tooling if pinch point is unavoidable.
16. Do not abuse tool by dropping or using it as a hammer. Never use hydraulic or air lines as a handle or to bend or pry the tool. Reasonable care of installation tools by operators is an important factor in maintaining tool efficiency, eliminating downtime, and preventing an accident which may cause severe personal injury.
17. Never place hands between nose assembly and work piece. Keep hands clear from front of tool.
18. Tools with ejector rods should never be cycled with out nose assembly installed.
19. When two piece lock bolts are being used always make sure the collar orientation is correct. See fastener data sheet for correct positioning.

II. PROJECTILE HAZARDS:

1. Risk of whipping compressed air hose if tool is pneudraulic or pneumatic.
2. Disconnect the assembly power tool from energy source when changing inserted tools or accessories.
3. Be aware that failure of the workpiece, accessories, or the inserted tool itself can generate high velocity projectiles.
4. Always wear impact resistant eye protection during tool operation. The grade of protection required should be assessed for each use.
5. The risk of others should also be assessed at this time.
6. Ensure that the workpiece is securely fixed.
7. Check that the means of protection from ejection of fastener or pintail is in place and operative.

8. There is possibility of forcible ejection of pintails or spent mandrels from front of tool.

III. OPERATING HAZARDS:

1. Use of tool can expose the operator's hands to hazards including: crushing, impacts, cuts, abrasions and heat. Wear suitable gloves to protect hands.
2. Operators and maintenance personnel shall be physically able to handle the bulk, weight and power of the tool.
3. Hold the tool correctly and be ready to counteract normal or sudden movements with both hands available.
4. Maintain a balanced body position and secure footing.
5. Release trigger or stop start device in case of interruption of energy supply.
6. Use only fluids and lubricants recommended by the manufacturer.
7. Avoid unsuitable postures, as it is likely for these not to allow counteracting of normal or unexpected tool movement.
8. If the assembly power tool is fixed to a suspension device, make sure that fixation is secure.
9. Beware of the risk of crushing or pinching if nose equipment is not fitted.

IV. REPETITIVE MOTION HAZARDS:

1. When using assembly power tool, the operator can experience discomfort in the hands, arms, shoulders, neck or other parts of the body.
2. When using tool, the operator should adopt a comfortable posture while maintaining a secure footing and avoid awkward or off balanced postures.
3. The operator should change posture during extended tasks to help avoid discomfort and fatigue.
4. If the operator experiences symptoms such as persistent or recurring discomfort, pain, throbbing, aching, tingling, numbness, burning sensations or stiffness, these warnings should not be ignored. The operator should tell the employer and consult a qualified health professional.

V. ACCESSORIES HAZARDS:

1. Disconnect tool from energy supply before changing inserted tool or accessory.
2. Use only sizes and types of accessories and consumables that are recommended. Do not use other types or sizes of accessories or consumables.

VI. WORKPLACE HAZARDS:

1. Be aware of slippery surfaces caused by use of the tool and of trip hazards caused by the air line or hydraulic hose.
2. Proceed with caution while in unfamiliar surroundings; there could be hidden hazards such as electricity or other utility lines.
3. The assembly power tool is not intended for use in potentially explosive environments.
4. Tool is not insulated against contact with electrical power.
5. Ensure there are no electrical cables, gas pipes, etc., which can cause a hazard if damaged by use of the tool.

VII. NOISE HAZARDS:

1. Exposure to high noise levels can cause permanent, disabling hearing loss and other problems such as tinnitus, therefore risk assessment and the implementation of proper controls is essential.
2. Appropriate controls to reduce the risk may include actions such as damping materials to prevent workpiece from 'ringing'.
3. Use hearing protection in accordance with employer's instructions and as required by occupational health and safety regulations.
4. Operate and maintain tool as recommended in the instruction handbook to prevent an unnecessary increase in the noise level.
5. Select, maintain and replace the consumable / inserted tool as recommended to prevent an unnecessary increase in noise.
6. If the power tool has a silencer, always ensure that it is in place and in good working order when the tool is being operated.

VIII. VIBRATION HAZARDS:

1. Exposure to vibration can cause disabling damage to the nerves and blood supply to the hands and arms.
2. Wear warm clothing when working in cold conditions and keep hands warm and dry.
3. If numbness, tingling, pain or whitening of the skin in the fingers or hands, stop using the tool, tell your employer and consult a physician.
4. Support the weight of the tool in a stand, tensioner or balancer in order to have a lighter grip on the tool.

IX. PNEUMATIC / PNEUDRAULIC TOOL SAFETY INSTRUCTIONS:

1. Air under pressure can cause severe injury.
2. Always shut off air supply, drain hose of air pressure and disconnect tool from air supply when not in use, before changing accessories or when making repairs.
3. Never direct air at yourself or anyone else.
4. Whipping hoses can cause severe injury, always check for damaged or loose hoses and fittings.
5. Cold air should be directed away from hands.
6. Whenever universal twist couplings (claw couplings) are used, lock pins shall be installed and whip-check safety cables shall be used to safeguard against possible hose to hose or hose to tool connection failure.
7. Do not exceed maximum air pressure stated on tool.
8. Never carry an air tool by the hose.

256BT Pneudraulic Installation Tool (HK1109)



Specifications

STROKE: 1.275 in (3.24 cm)

WEIGHT: 11.0 lbs (5.0 kg)

MAX AIR PRESSURE: 90 psi (6.2 bar)

MAX FLOW RATE: 22.4 scfm (634.37 l/min)

CAPACITY:

6700 lbs @ 90 psi (29.80 kN @ 6.2 bar)

SPEED / CYCLES: 30 per minute

MAX OPERATING TEMP:

125° F (51.7° C)

POWER SOURCE:

Huck Powerig® hydraulic power source

HYDRAULIC FLUID:

Hydraulic fluid shall meet DEXRON® III, DEXRON VI, MERCON®, Allison C-4 or equivalent Automatic Transmission Fluid (ATF) specifications. Fire-resistant fluid may be used if it is an ester-based fluid such as Quintolubric® HFD or equivalent. Water-based fluid shall NOT be used as serious damage to equipment will occur.

Where the following trade names are used in this manual, please note:

DEXRON is a registered trademark of General Motors Corporation.
GLYD Ring is a registered trademark of Trelleborg Sealing Solutions Germany GmbH
Loctite is a registered trademark of Henkel Corporation, U.S.A.
LUBRIPLATE is a registered trademark of Fiske Brothers Refining Co.
MERCON is a registered trademark of Ford Motor Corp.
MOLYKOTE is a registered trademark of Dow Corning Corporation
Never-Seez is a registered trademark of Bostik, Inc.
Quintolubric is a registered trademark of Quaker Chemical Corp.
Slic-tite is a registered trademark of LA-CO Industries, Inc.
Spirolox is a registered trademark of Smalley Steel Ring Company
Teflon is a registered trademark of Chemours Company FC.
Threadmate is a registered trademark of Parker Intangibles LLC.
TRUARC is a trademark of TRUARC Co. LLC.
Vibra-Tite is a registered trademark of ND Industries, Inc. USA.

NOTE: This tool comes labeled with important safety and information stickers.

Any time a sticker becomes worn, damaged, unreadable, or is missing, it must be ordered and replaced where indicated on the tool. See Figure 12 on page 13 of this manual for sticker information.

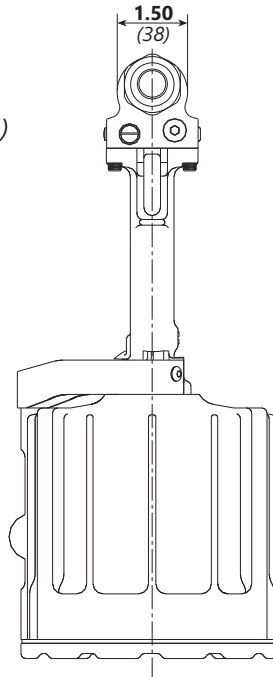

INCHES
(mm)

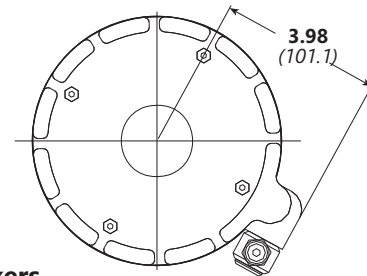
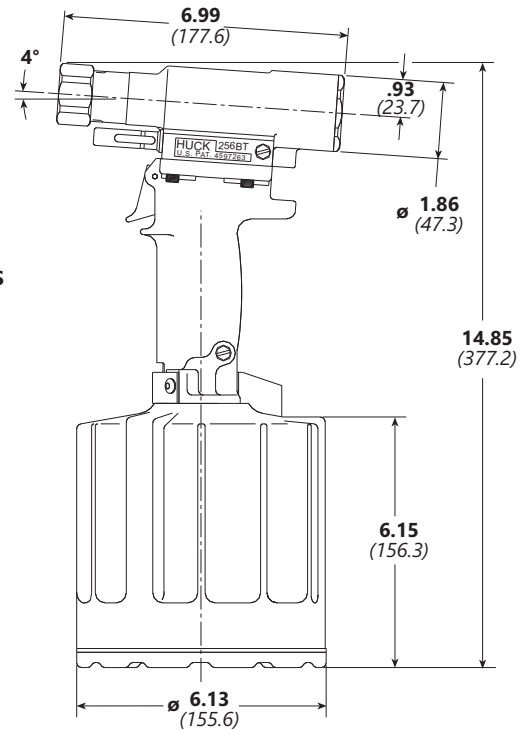

Principle of Operation

PULL STROKE

When the trigger is pressed, the throttle valve moves down to the PULL position, and pressurized air is directed to the bottom of the air piston, causing it to move upward. The air above the air piston is exhausted and directed through the center of the throttle valve and out the bottom of the tool. The air piston has a rod and a hydraulic piston attached. As the air piston rod moves upward, a column of pressurized fluid is forced into the head, which moves the pull piston rearward. The attached nose assembly moves with the pull piston spindle to start the fastener installation.

RETURN STROKE

When fastener installation is completed, the trigger is released. Air pressure, with the assistance of a spring, sends the throttle valve to the up (RETURN) position. Pressurized air is re-directed to the top of the air piston, causing the air piston to move downward. The air from below the piston is exhausted through the bottom of the tool. The rod and hydraulic piston move downward; hydraulic pressure is reversed and the pull piston is returned forward. The return pressure relief valve protects the tool against pressure spikes. The reservoir replenishes the hydraulic system as needed.

Attaching a Nose Assembly

1. Remove retaining nut and stop from tool. (Figure 11)
2. Using a 3/8" T-handle wrench from the rear of the tool, hold the pull piston in place, and attach the nose assembly puller. Tighten using a 5/8" wrench on the puller flats.
3. Using a soft mallet, gently tap the anvil assembly over the puller until it bottoms on the tool.
4. Secure nose assembly by screwing retaining nut over the anvil assembly, onto front of tool, and wrench-tighten with a 1 3/8" wrench.



Preparation for Use and Operating Instructions

This tool is shipped with a 1/4" inside diameter air hose (Huck p/n 115436), with a plastic plug in the air inlet connector. An air supply capable of 6.3 CFM to supply a pressure of 10 psi greater than the tool pressure to swage the fastener (Figure 12) must be available. Air supply should be equipped with a filter-regulator-lubricator unit.



WARNINGS:

Read full manual before using tool.
 Inspect tool for damage or wear before each use. Do not operate if damaged or worn, as severe personal injury may occur.
 A half-hour training session with qualified personnel is recommended before using Huck equipment.
 When operating Huck installation equipment, always wear approved eye protection.
 Be sure there is adequate clearance for the operator's hands before proceeding.

1. Remove plastic shipping plug from air hose and put in a few drops of Automatic Transmission Fluid, DEXRON III, or equivalent.
2. Screw quick disconnect fitting into Air Inlet Connector.
3. Set air pressure on regulator to 10 psi above the attached regulator set point.
4. Attach air hose to air power source.
5. Cycle tool a few times by depressing and releasing trigger.
6. Disconnect air hose from tool.
7. Remove Retaining Nut and Stop.
8. Select proper Nose Assembly for fastener to be installed.
9. Attach Nose Assembly.
10. Connect air hose to tool and install fastener(s) in test plate of proper thickness with proper size holes. Inspect fastener(s).



CAUTIONS:

Do not let disconnected hoses and couplers contact a dirty floor. Keep harmful material out of hydraulic fluid. Dirt in hydraulic fluid causes valve failure in Tool and In Powerig Hydraulic Unit.
 Do not use TEFLON® tape on pipe threads. Pipe threads may cause tape to shred resulting in tool malfunction. (Threadmate™ is available from Huck in a 4oz. tube as part number 508517.)

NOTE: Air quick disconnect fittings and air hoses are not available from Huck International, Inc.

FOR SAFE OPERATION, THIS SECTION MUST BE READ AND UNDERSTOOD.

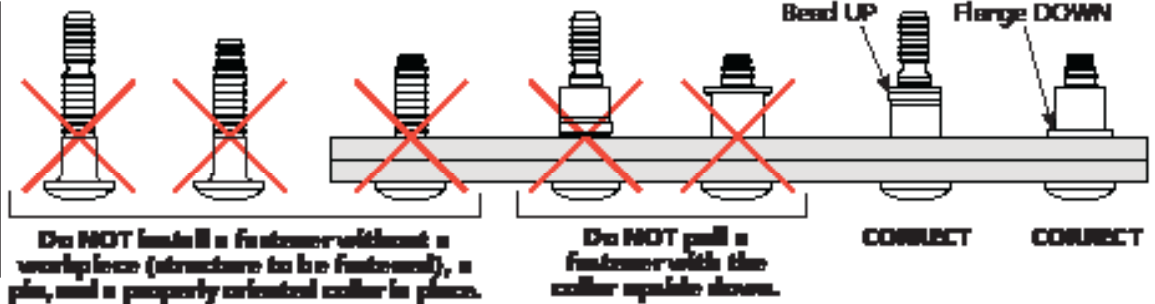

WARNINGS:

To avoid severe personal injury, wear approved eye and ear protection. Be sure of adequate clearance for operator's hands before proceeding with fastener installation.
 If the tool comes with a pintail deflector or bottle, make sure it is attached to the tool and directed away from all personnel.
 Do NOT attempt to install a pin without placing the fastener and collar in the work piece (structure to be fastened).
 Do NOT attempt to install a pin without a properly oriented collar in place. The collar flange must be against work piece.
 If these safety measures are not followed, the fastener could eject with great velocity and cause severe personal injury. This condition can cause pin to eject with great velocity and force if the pintail breaks off or teeth/grooves strip. This may cause severe personal injury.
 To avoid pinch point, never place hand between nose assembly and work piece.
 Only use compatible equipment with this tool.



CAUTIONS: Remove excess gap from between the sheets. This permits enough pintail to emerge from collar for ALL jaw teeth to engage with pintail. If ALL teeth do not engage properly, jaws will be damaged.

Note: In certain situations, it may be permissible to use a BobTail tool and fastener without a collar to remove sheet gap prior to full installation with a collar. Consult qualified Huck engineering personnel before attempting this operation.

GENERAL PRECAUTIONS

If a tool malfunctions, consult **TROUBLESHOOTING** in this manual before attempting any repairs. Operators should receive training from qualified personnel. Do not bend tool to free if stuck. A tool should only be used to install fasteners; never as a jack/spreader or hammer. **NOTE: Reasonable care of tools by operators is an important factor of tool efficiency and reducing downtime.**

TO INSTALL A BobTail® FASTENER

Check pin for correct grip. Place a fastener in the workpiece and place the collar over the fastener.

Hold the pin in the hole and push the nose assembly onto the pin protruding through the collar until the puller assembly bottoms on the fastener
 Move hands away from fastener and structure. Keep hands away from front of tool during operation.
 Hold tool at right angle (90 degrees) to work. Press and hold the trigger until the collar is swaged.
 Release the trigger; the tool will perform its RETURN stroke. The pressure is re-directed; the piston moves forward; and the tool is pushed off the fastener and ready for the next installation cycle.

256BT Pneudraulic Installation Tool (HK1109)



Measuring Tool Stroke

1. With the piston in the full-forward position, measure **DISTANCE A** from face of the cylinder to the face of the piston.
2. Cycle the tool and keep the piston in the full-rearward position by holding the trigger pressed. Measure **DISTANCE B** as above.

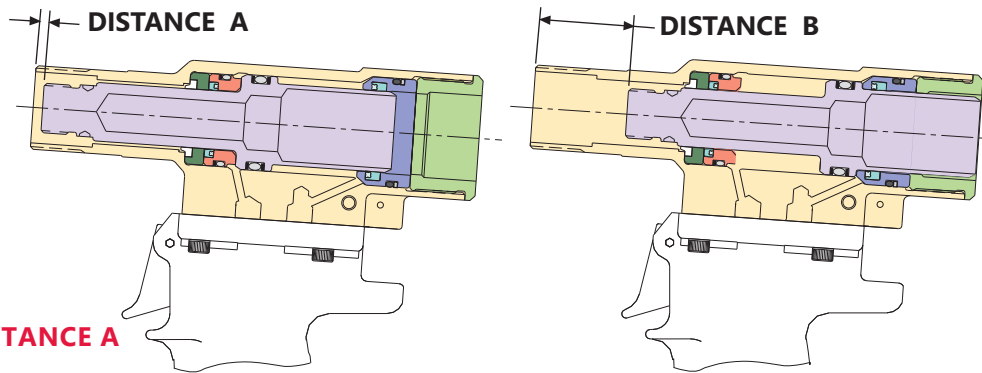

TOOL STROKE = DISTANCE B - DISTANCE A

Maintenance



WARNING: Inspect tool for damage and wear before each use. Do NOT operate if damaged or worn as serious personal injury may occur.



CAUTIONS:
Keep foreign matter out of the hydraulic system. Keep separated parts away from dirty work surfaces.

Dirt and debris in hydraulic fluid causes valve failures in tool and the Powerig® hydraulic power source.

Replace all seals, wipers, and rings when the tool is disassembled for any reason, and at regular intervals, depending on severity and length of use.

Do not use Teflon® tape on pipe threads. Tape can shred, resulting in malfunctions.

NOTE: See SPECIFICATIONS for fluid type. Dispose of fluid in accordance with local environmental regulations. Recycle steel, aluminum, and plastic parts in accordance with local lawful and safe practices.

GENERAL

The operating efficiency of your tool is directly related to the performance of the entire system. Regular inspection and the immediate correction of minor problems will keep the tool operating efficiently, and prevent downtime. A schedule of "preventive" maintenance of the tool, nose assembly, hoses, trigger and control cord, and Powerig will ensure proper tool operation and extend its life. **NOTE: Huck tools should be serviced only by personnel who are thoroughly familiar with its operation.**

Service the tool in a clean, well-lit area. *Prevent contamination of pneumatic and hydraulic systems!*

Keep all necessary maintenance hand tools and spare parts on-hand. See **KITS & ACCESSORIES**.

Disassemble and assemble tool components in a straight line. Do NOT bend, cock, twist, or apply undue force.

Carefully handle all parts. Before reassembly, examine them for damage and wear.

Smear LUBRIPLATE® 130-AA (Huck P/N **502723**) or SUPER-O-LUBE® (Huck P/N **505476**) on O-rings, Quad-rings, Back-up rings, and mating parts to ease assembly.

Apply Parker Threadmate®, Loctite® 567, or Slic-Tite® to male pipe threads, hose fitting threads, and quick connect fittings (per manufacturer's instructions) to prevent leaks and to ease assembly.

DAILY

Check the fluid level in the tool reservoir; replenish as necessary. If a Filter-Regulator-Lubricator is not being used, uncouple the air disconnects and add a few drops of fluid or a light-weight oil to the air inlet of the tool.

NOTE: If the tool is in continuous use, add a few drops of fluid every 2–3 hours.

Before connecting an air hose to the tool, clear the air lines of dirt and water.

Check all hoses and couplings for damage and air leaks; tighten or replace if necessary. Check the tool for damage and air or hydraulic leaks; tighten, repair, or replace if necessary.

Inspect the tool, hoses, and Powerig during operation to detect abnormal heating, leaks, or vibration.

Check the nose assembly for tightness and damage.

Clean nose assemblies in mineral spirits to clear jaws and rinse metal chips and dirt. For a more thorough cleaning, disassemble the nose assembly. Use a pointed "pick" to remove embedded particles from the pull grooves of the jaws.

Clean all parts of any assembly with UNITIZED™ Jaws in mineral spirits or isopropyl alcohol only; do not let jaws come in contact with other solvents. Do not let jaws soak; dry them *immediately* after cleaning. Huck recommends drying other parts before re-assembling.

Periodically, check the tool stroke. If the stroke is short, add fluid. See **MEASURING TOOL STROKE**.

WEEKLY

Disassemble, clean, and re-assemble nose assembly in accordance with applicable instructions. Check the tool and all connecting parts for damage and fluid/air leaks; tighten or replace if necessary.



Disassembly

WARNING: Disconnect the air hose from the tool before performing any maintenance. Serious personal injury could result if the air hose is connected.

CAUTION: Always use a soft-jaw vise to avoid damaging the tool.

This procedure is for complete disassembly of the tool. Disassemble **only** those components necessary to replace damaged O-rings, Quad-rings, Back-up rings, and worn and damaged components.

1. Disconnect air hose from tool.
2. Remove nose assembly.
3. Insert Fill Tool (P/N **129633**) through reservoir housing and screw it into the reservoir plunger, until it bottoms out; then lock it in the lock-out position. (Figure 1)
4. Unscrew four cap screws with a 5/32" hex key, and carefully separate head from handle. Remove the pull and return gland assemblies, and remove the seals from the glands. (Figure 1) Turn the tool handle and base over to empty the hydraulic fluid; then set aside.
5. Unscrew the relief valve plug from the front of the head. Then remove the spring, guide, ball, and sleeve. A small magnet is helpful.
6. Unscrew the check valve plug just enough to unseat the O-ring; then unscrew and remove the reservoir fill plug. Slowly release the fill tool, and drain the fluid into a container. Discard the fluid.
7. Unscrew the reservoir housing from the head. Then remove the two springs, and slide the reservoir plunger out of the head. Remove the spacer and use a pick to remove the Quad-ring.
8. Remove the check valve plug; then remove the spring, guide, and ball. (Figure 1)

NOTE: If the check valve seat is damaged, it must be replaced; it cannot be reused. Contact your Huck representative. It can be removed by using the following procedure.

9. Relief Valve Seat Assembly Removal: (Figures 1 & 11)
All parts in the check valve hole must be removed before the Plug "A" can be removed. Use a 3/16" Allen wrench to remove Screw "B". Then insert a #10 screw in the thread of the Plug "A", and pull to remove. Use a small drift and hammer and, from the rear of the head, drive the remaining components out through the front of the head.
10. Unscrew the cylinder cap from the head with 1-11/16" open-end wrench.
11. Place Spacer on Hydraulic Pull Piston, and screw Assembly/Disassembly Bullet onto piston. Tap or press piston assembly out of head through rear of tool. **This will push out front and rear gland assemblies and wiper and wiper housing.** (Figure 2)

Figure 1

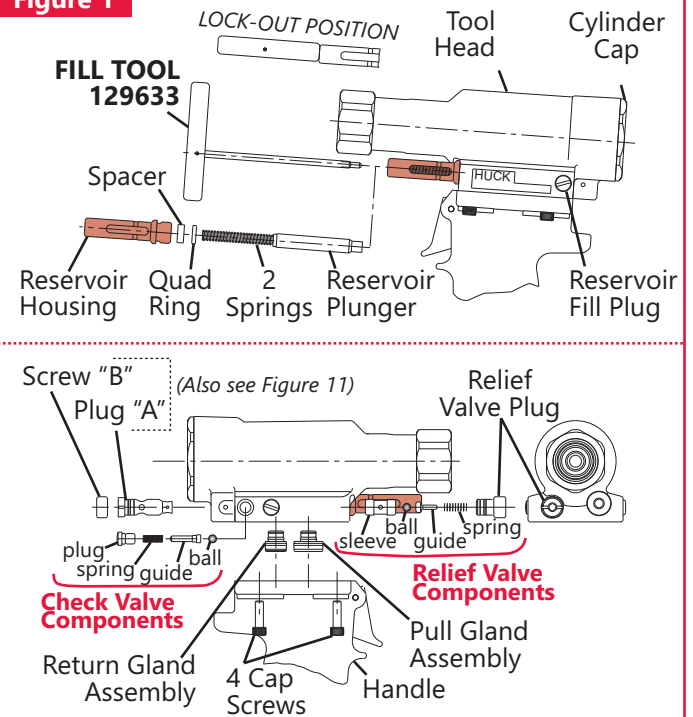
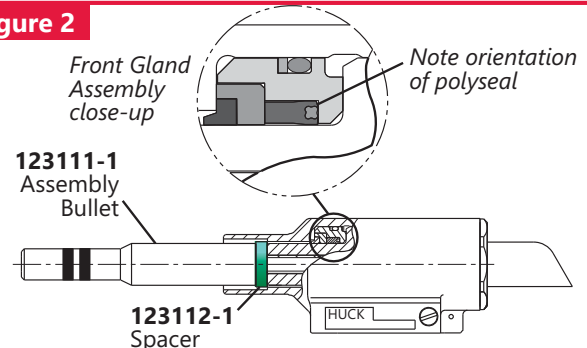

Figure 2



NOTE: Spacer must only be used for disassembly procedure as it assists in pushing out Front Gland Assembly.

12. Remove two screws from the throttle arm guard; remove guard.
13. Remove the screw from the throttle arm, and then remove the throttle arm. Remove the throttle valve and spring from the cylinder. (Figure 11)
14. With a small punch and hammer, drive out roll pin to remove the trigger from the handle. (Figure 11) Remove the trigger pin. Remove ball end of the cable from the throttle arm, and pull cable out of handle.
15. Remove the bleed plug from the handle. (Figure 1)
16. Secure the tool upside-down in a soft-jaw vise, and use a 1/8" hex key to unscrew the 4 button-head screws; then remove the muffler end cap, bottom exhaust gasket, muffler and O-ring. (Figure 3)
17. Tap the cylinder head down into the cylinder; then remove the retaining ring from the cylinder assembly. (Figure 3)

continued

256BT Pneudraulic Installation Tool (HK1109)



Disassembly continued

18. Screw the cap screws into the cylinder head, and carefully pry on them to remove the cylinder head.
19. Push air piston all the way down in the cylinder, remove tool from vise, and lay on its side. Hold the nut with a 5/8" socket and extension, and use a 3/16" hex key to remove the intensifier piston assembly. (Figures 3, 11, and 12)
20. Secure the cylinder assembly and handle upside-down in a vise again. Use pliers to grip the nut and pull out the air piston and rod assembly from the handle and cylinder assemblies.

CAUTION: DO NOT scratch the piston, rod, or cylinder when removing.

21. Use a 1-3/8" socket and extension to remove the gland housing of the main gland assembly. Take off the air cylinder, and set it aside. (Figures 3 & 12)
22. To remove the remaining gland from the handle, use a 17/32-20 bolt, and thread it in to pull out the gland.
23. Remove the retaining ring and spacer from the gland assembly, then remove the Polyseal. The tool has been properly disassembled. Store all *re-usable* parts (screws and disassembled components) in a clean, dry area.

WARNING: Do NOT re-use any seals, wipers, or rings; irreparable tool damage could occur. Discard these parts and use replacements (see KITS & ACCESSORIES).

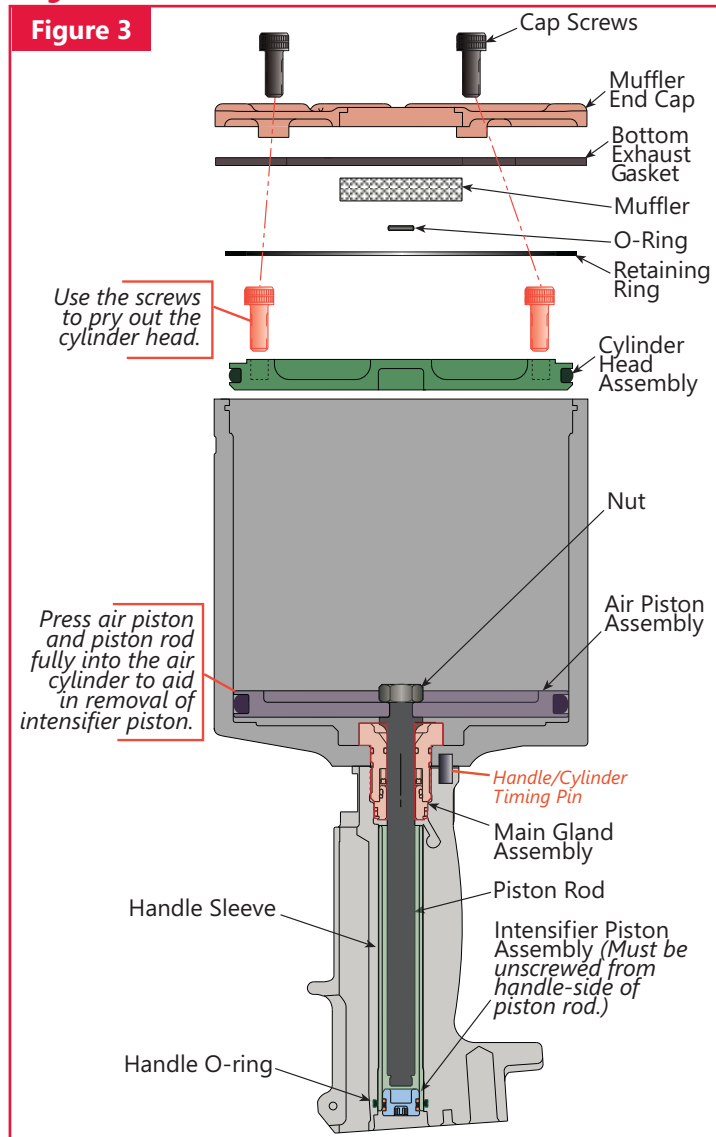

Assembly

WARNINGS: Do not omit any seals during servicing, leaks will result and personal injury may occur. Make sure tool is fully assembled, with all components included.

CAUTION: Do NOT scratch the piston, rod, or cylinder.

Clean components with mineral spirits or similar solvent. Inspect for wear/damage and replace as necessary. Replace all seals of disassembled components using Service Parts Kit, P/N 256KIT. Smear LUBRIPLATE 130AA or PARKER-O-LUBE on rings and mating parts to ease assembly. Carefully assemble tool without damaging O-rings, Quad rings, or Back-up rings.

1. (Figure 4) Install O-ring inside handle; then push sleeve in handle until it bottoms on the chamfer.
2. Holding handle inverted in a vice, install timing pin;

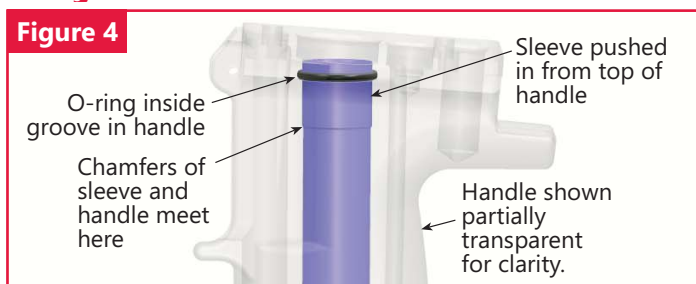

then place air cylinder on handle with timing pin positioned in matching hole. Assemble the Main Gland Assembly with new seals; apply anti-seize compound (P/N 508183) to the threads. With a 1-3/8 inch socket wrench, torque it into the handle to 75-85 ft.-lbs.

3. Assemble the Piston Rod to the Air Piston (with O-ring in place). Apply Loctite 243 to threads on the bottom of piston rod and secure with the Nut. Torque Nut to 28-32 ft.-lbs; then press assembled Piston Rod/Air Piston into the Air Cylinder and Main Gland, until it bottoms out on the Gland.

continued



Assembly continued

4. Turn tool upright. Assemble Intensifier Piston with O-Ring and Back-up Rings; then apply Loctite® 243 to intensifier piston screw threads, and carefully press in from top of handle. To screw Intensifier Piston onto the piston rod, hold the nut with a 5/8" socket and extension, and use a 3/16" hex key to torque the Intensifier Piston to 180-190 in.-lbs.
5. Secure the head upside-down in a vise. Press the cylinder head (with O-ring in place) squarely into the cylinder, taking care not to damage O-ring. Install the retaining ring. (Figures 3 & 11)
6. Position the O-ring and muffler in the center of the cylinder assembly. Position the gasket on the cylinder assembly. Carefully position the gasket and muffler end cap on the cylinder, making sure that the it is properly positioned. Secure muffler end cap with four cap screws using a 1/8" hex key.
7. Place the tool upright on a level surface. (Figure 5) Drop the spring into the throttle valve hole in the cylinder, and push the throttle valve assembly (with rings in place) into the cylinder.
8. Assemble Trigger, Cable, and Cable Pin, and slide Cable into Handle. Align hole in Trigger with hole in Handle and install Trigger Pin with a hammer and punch.

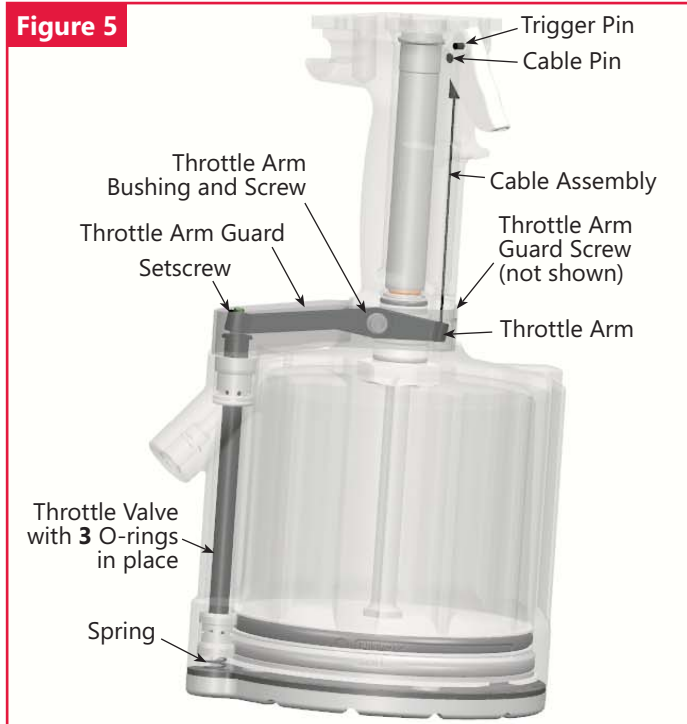

9. Slide Throttle Arm onto ball end of throttle cable. Swing arm until end fits over throttle valve. Attach throttle arm Bushing and Screw to Throttle Arm. Tighten with 5/32 hex key.
10. Reinstall the air hose assembly if it was removed.
NOTE: If Relief Valve Seat Assy is being replaced, push Plug "A", with seals in place, into head. Install Screw "B". (Figure 1)

11. Install the O-ring and Back-up ring onto seat. Carefully drive Relief Valve Seat Assy in using a soft drift, without damaging Relief Valve Ball surface.
12. Assemble the pull piston with new seals that have been lubricated with LUBRIPLATE® 130-AA or SUPER-O-LUBE®. (Figure 12)
13. Thread Assembly Bullet onto Pull Piston Assy. (Figure 2) **NOTE: The Spacer is not needed during assembly; its purpose is to push out the front gland during disassembly.**
14. Push Front Gland Assy, with seals, Housing, and Wiper in place, over Assembly Bullet and onto Pull Piston. Push entire gland and piston assembly into Head.
15. Install O-rings and Back-up Rings on Rear Gland and push complete assembly into Head. Screw in Cylinder Cap and tighten.
16. Install the O-ring and Back-up ring on the relief valve plug. (Figure 9) Insert the ball, guide, sleeve, spring, and plug into the head.
17. Install the O-ring on the check valve plug. Insert the ball, guide, spring, and plug into the head.
18. Screw the bleed plug assemblies (with O-ring in place) into the handle and cylinder head.
19. Install the O-rings and Back-up rings on the pull gland assembly; and the O-rings and Back-up rings on the return gland assembly. Push these assemblies into the handle. (Figure 6) Push the head down onto the handle, aligning it with the pull and return gland assemblies. Place the tool upside-down in a vise, and install the 4 cap screws; torque to 170 in.-lbs.

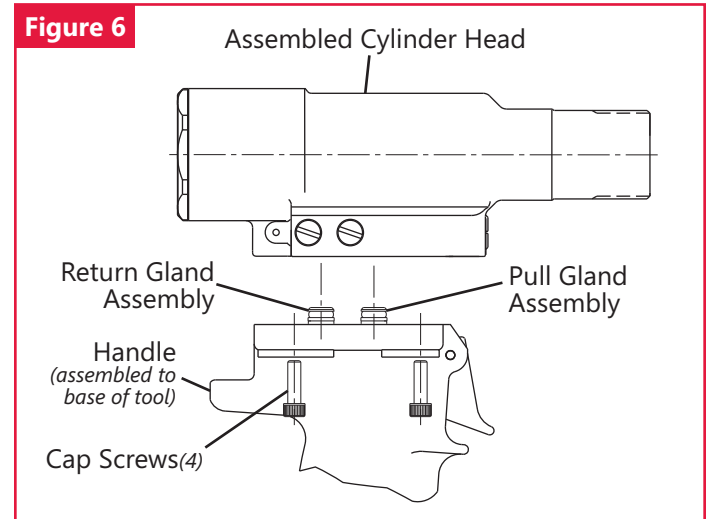

The tool is now assembled and must be filled with hydraulic fluid prior to use. See **FILL AND BLEED**.

256BT Pneudraulic Installation Tool (HK1109)



Fill and Bleed

WARNING: Avoid contact with hydraulic fluid. Hydraulic fluid must be disposed of in accordance with local regulations. See MSDS for hydraulic fluid shipped with tool.

- Remove the relief valve plug and the check valve plug (Figure 8), as well as all guides, springs, and balls, from the ports in the head. Re-insert the relief valve plug. (Figures 8 & 9)

REQUIRED EQUIPMENT:

- DEXRON® III or equivalent ATF (See **SPECIFICATIONS**)
- Shop air-line with 90 psi (6.2 bar) max.
- Air regulator
- Large flat-blade screwdriver
- Fill Bottle Assembly, p/n 120337, included with tool (Figure 7)
- Nose assembly or optional Stall Nut, p/n 120824
- Fasteners (optional)

PREPARATION:

- Install the air regulator in the air-line and set the pressure to 20–40 psi (1.4–2.8 BAR).
- Add an approved hydraulic fluid to the fill point of the Fill Bottle. (Figure 7)

NOTE: Refill the tool only when the fluid level drops below the red line on the reservoir housing; or when the tool is rebuilt.

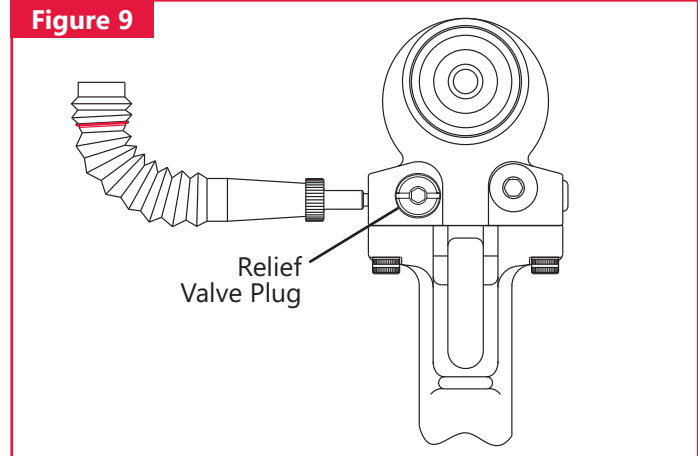
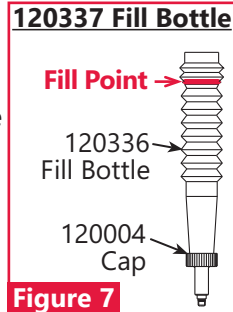

- Screw the retaining nut onto the head assembly, and screw the stall nut onto the hydraulic piston. Tighten to ensure full thread engagement.

NOTE: Back off the retaining nut until it engages the stall nut. Verify that the hydraulic piston is full forward and locked with the retaining nut (and, optionally, with the stall nut). If the stall nut is not used, the piston must be pushed to the full-forward position before installing the valves.

TO BLEED AND FILL THE TOOL:

CAUTION: Purge all fluid from the tool before refilling. The tool stroke will be diminished if the fluid is aerated. For optimal performance, refill with a fluid that is recommended in **SPECIFICATIONS**.

- Screw the Fill Tool into the reservoir plunger. Pull the plunger into the reservoir housing and lock Fill Tool in the full-forward position by tilting the handle (long side touching tool) and locking it in place. (Figure 8)

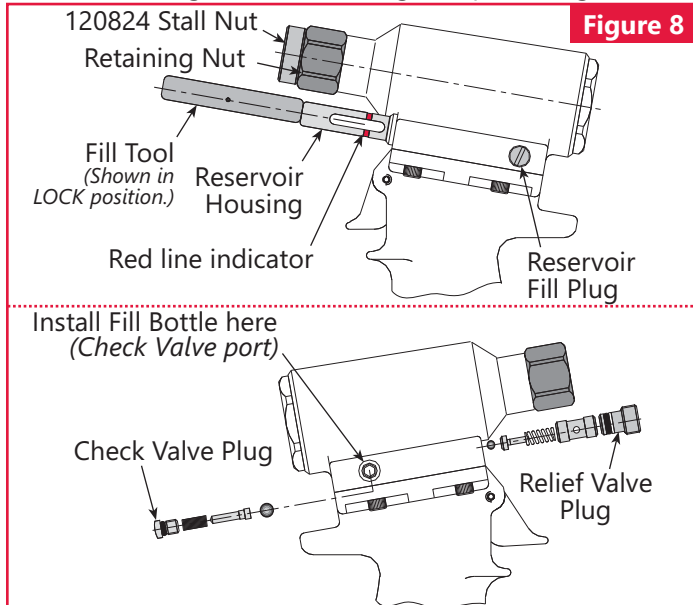

- Connect the tool to the air source to seat the air piston at the bottom of the air cylinder; then disconnect. Lay tool on its side with the fill port facing up.
- Insert the fill bottle in the fill port (check valve hole). (Figures 8 & 9)
- Connect the tool to the air supply and cycle it 20–30 times; watch for air bubbles escaping into the bottle. (Rock the tool to free trapped air.)

WARNING: Air pressure must be set at 20–40 psi (1.4–2.8 BAR) to prevent possible injury from high-pressure spray. If the plug is removed, the fill bottle must be in place before cycling the tool.

NOTE: Do not allow air to re-enter the tool. When cycling the tool, hold the fill bottle as shown in Figure 8 to prevent drawing in air.

- When air bubbles stop accumulating in the fill bottle, stop cycling the tool. Remove the bottle and replace the plug.

continued



Fill and Bleed continued

8. Install the check valve ball, guide, and spring. Replace the check valve plug.
9. Turn the tool so the front of the head faces you. Back out (approximately 1/2 turn counterclockwise) the setscrew that is inside the relief valve plug. This ensures that the piston remains in the full-forward position. (Figure 10) Remove the relief valve plug; insert the ball, guide, sleeve, and spring, and then re-insert the plug. Immediately re-tighten the setscrew.
10. Unlock the Fill Tool and check the fluid level (Red line indicator, Figure 7) in the reservoir housing. Cycle the tool with the stall nut attached and the retaining nut locked in the full-forward position ("dead stall"). The fluid level should not drop below the red line on the reservoir housing. **NOTE: If the stall nut was not used, Dead Stalling is not necessary; just cycle tool.**
11. Re-lock the fill tool in out position. Lay the tool on its side with the reservoir facing up, and remove the bleed plug. Insert the fill bottle and add a few drops of fluid to the reservoir; wait for air bubbles to escape, then remove the fill bottle. (Push a pin or a scribe into the reservoir fill port to check for trapped air bubbles.) Replace the plug.



WARNING: Failure to re-lock the fill tool will result in oil ejecting from the head under pressure during the topping off of the reservoir.

Severe personal injury may result.

12. Unlock the Fill Tool, cycle the tool as in step 10, and check the fluid level in the reservoir housing. The reservoir fluid level may drop slightly. If so, repeat these steps until, when the Fill Tool handle is touched, it has no pressure against it and it drops out of the lock position, and the fluid level in the reservoir housing does not drop when the tool is cycled.

NOTE: This usually requires 3 to 4 repetitions.

13. When the fluid level is sufficient, remove the Fill Tool and stall nut. Install a nose assembly and pull several fasteners to test function.

Figure 10

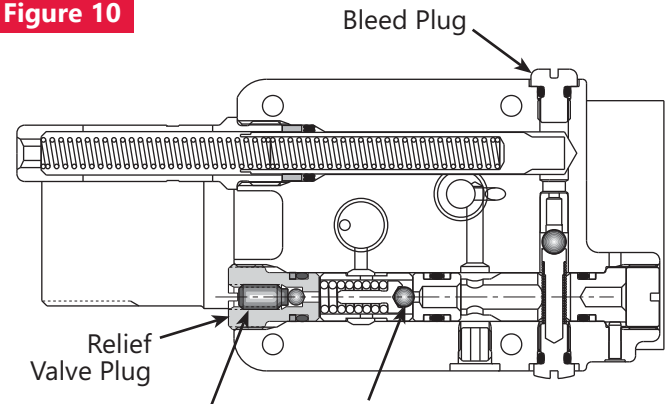

Using a 3/32 Allen wrench, loosen setscrew inside Plug by approx. 1/2 turn.

SECTION A-A
from Figure 11



Components Drawing

Figure 11

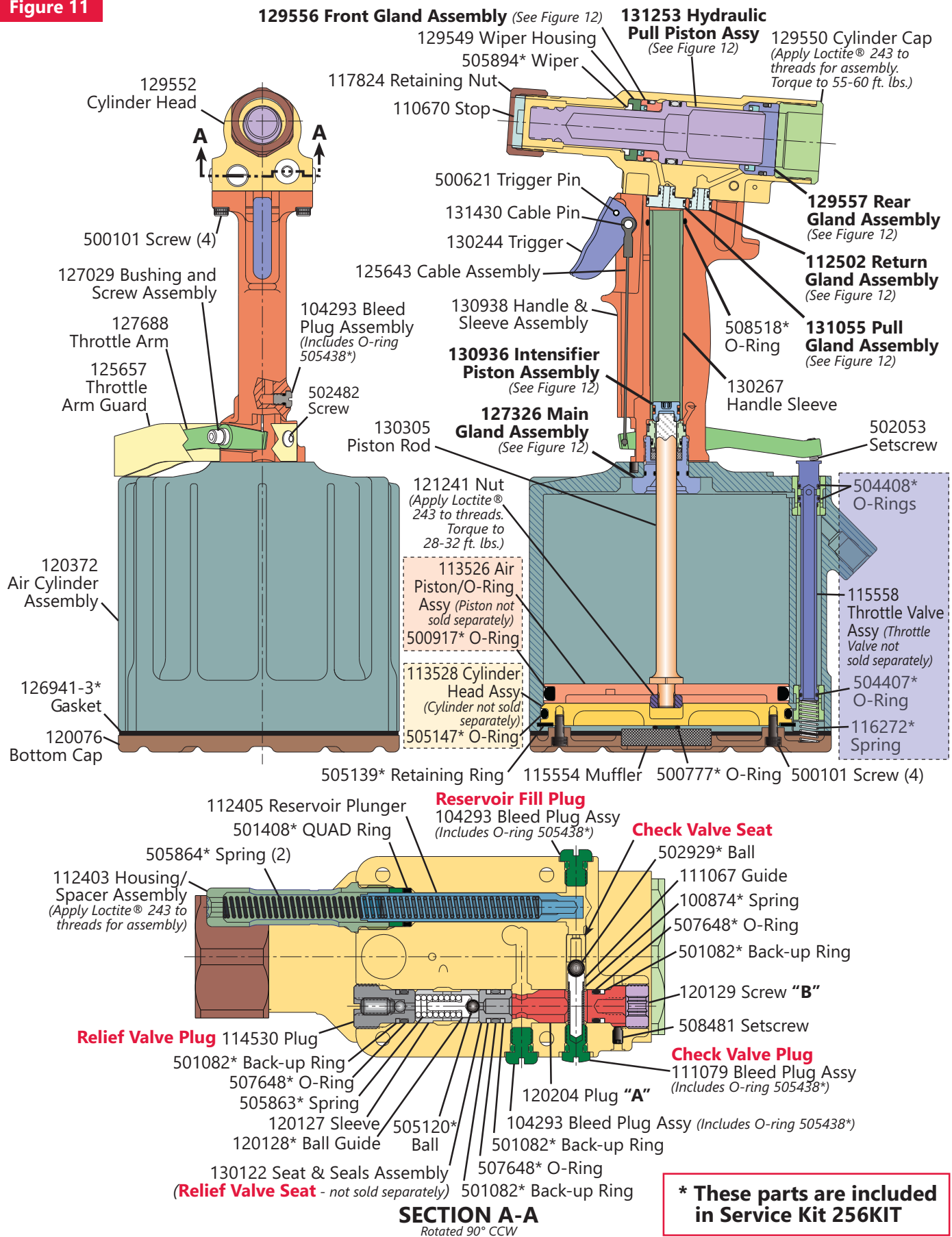



Subassembly Components and Sticker Locations

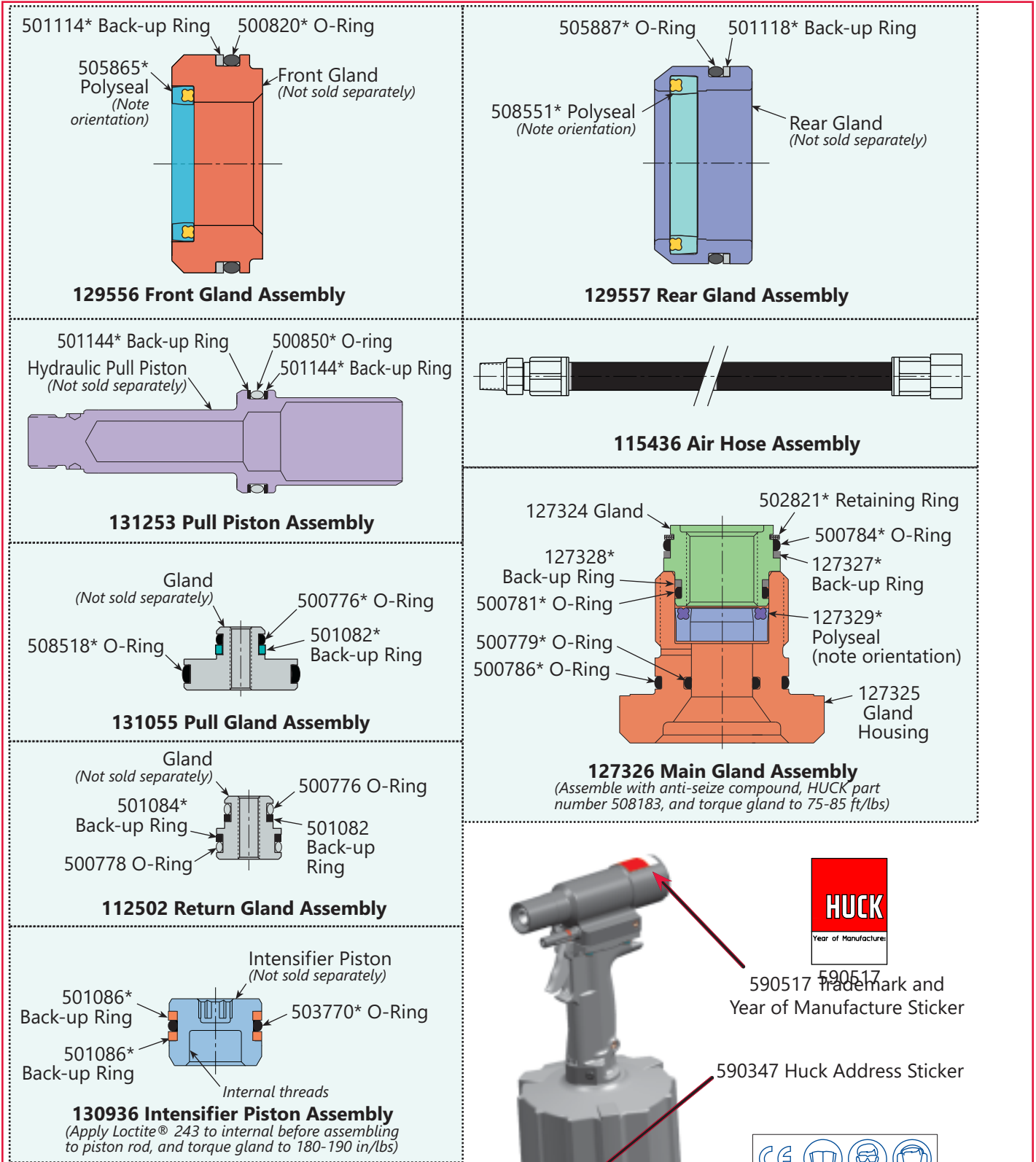

*** These parts are included in Service Kit 256KIT**



Figure 12



Troubleshooting

Always check the simplest possible cause (such as a loose or disconnected trigger line) of a malfunction first. Then proceed logically, eliminating other possible causes until the cause is discovered. Where possible, substitute known good parts for suspected defective parts. Use this Troubleshooting information to aid in locating and correcting trouble.

NOTE: "Piston drift" is when the air piston is in the down position, but the hydraulic pull piston is not in the full-forward position. This causes an out-of-sequence condition.

1. Tool fails to operate when trigger is pressed.
 - a. Air-line not connected.
 - b. Worn or damaged throttle valve O-rings.
 - c. Broken throttle valve cable assembly.
2. Tool does not complete fastener installation.
 - a. Air pressure too low.
 - b. Worn or damaged air piston O-Ring.
 - c. Tool is low on hydraulic fluid, or empty. See the FILL AND BLEED section.
 - d. Air in the hydraulic system. See the FILL AND BLEED section.
 - e. Worn or damaged reservoir springs.
 - f. Check for piston drift.
3. Pintail stripped and/or swaged collar not ejected.
 - a. Check for broken or worn puller in nose assembly. See Nose Assembly Data Sheet.
 - b. Check for loose retaining nut.
 - c. Check for piston drift.
4. Hydraulic fluid exhausts with air or leaks at base of handle.
 - a. Worn or damaged gland assembly. Inspect Polyseal, O-rings, and Quad-ring. Replace if necessary.
5. Tool has piston drift.
 - a. Loose collet crashing into the front of the anvil causing the relief valve to open, allowing the piston to drift. Tighten the collet. See the FILL AND BLEED section.
 - b. Worn or damaged return pressure relief valve. Inspect seat assembly, O-ring, Back-up rings, steel ball, and valve spring. Replace if necessary.
 - c. Worn or damaged Piston Assembly. Inspect O-rings and Back-up rings. Replace if necessary.
6. Hydraulic fluid leaks at rear of pull piston.
 - a. Worn or damaged rear gland. Inspect Polyseal and O-ring. Replace if necessary.
7. Hydraulic fluid leaks at front of pull piston.
 - a. Worn or damaged front gland. Inspect Polyseal, O-ring, and Back-up ring. Replace if necessary.
8. Pull piston will not return.
 - a. Throttle valve stuck; lubricate O-rings.
 - b. Throttle arm, cable, or trigger binding.
9. Air leaks at air cylinder head.
 - a. Worn or damaged O-ring. Replace if necessary.

Kits & Accessories

The Spare Parts Service Kit contain various perishable parts for each tool. These parts are indicated by an asterisk in Figures 11 & 12. Keep a kit and appropriate hand tools accessible when using this tool and when performing maintenance on it. Huck also recommends having the following Accessories available when preparing, using, and performing maintenance on this tool.

KITS

Service Kit - 256BTKIT

ACCESSORIES

Stall Nut - 120824
 Fill and Bleed Bottle - 120337
 Fill Tool Assembly - 129633
 (for reservoir)



Limited Warranties

Limited Lifetime Warranty on BobTail® Tools:

Huck International, Inc. warrants to the original purchaser that its BobTail® installation tools manufactured after 12/1/2016 shall be free from defects in materials and workmanship for its **useful lifetime**. This warranty does not cover special order / non-standard products, or part failure due to normal wear, tool abuse or misapplication, or user non-compliance with the service requirements and conditions detailed in the product literature.

Two Year Limited Warranty on Installation Tools:

Huck International, Inc. warrants that its installation tools and Powerig® hydraulic power sources manufactured after December 1, 2016 shall be free from defects in materials and workmanship for a period of two years from date of purchase by the end user. This warranty does not cover special order / non-standard products, or part failure due to normal wear, tool abuse or misapplication, or user non-compliance with the service requirements and conditions detailed in the product literature.

90 Day Limited Warranty on Nose Assemblies and Accessories:

Huck International, Inc. warrants that its nose assemblies and accessories shall be free from defects in materials and workmanship for a period of 90 days from date of purchase by the end user. This warranty does not cover special clearance noses, or special order / non-standard product, or part failure due to normal wear, abuse or misapplication, or user non-compliance with the service requirements and conditions detailed in the product literature.

Useful lifetime is defined as the period over which the product is expected to last physically, up to the point when replacement is required due to either normal in-service wear, or as part of a complete overhaul. Determination is made on a case-by case basis upon return of parts to Huck International, Inc. for evaluation.

Tooling, Part(s) and Other Items not manufactured by Huck:

HUCK makes no warranty with respect to the tooling, part(s), or other items manufactured by third parties. HUCK expressly disclaims any warranty expressed or implied, as to the condition, design, operation, merchantability, or fitness for use of any tool, part(s), or other items thereof not manufactured by HUCK. HUCK shall not be liable for any loss or damage, directly or indirectly, arising from the use of such tooling, part(s), or other items or breach of warranty or for any claim for incidental or consequential damages.

Huck shall not be liable for any loss or damage resulting from delays or non-fulfillment of orders owing to strikes, fires, accidents, transportation companies or for any reason or reasons beyond the control of the Huck or its suppliers.

Huck Installation Equipment:

Huck International, Inc. reserves the right to make changes in specifications and design and to discontinue models without notice.

Huck Installation Equipment should be serviced by trained service technicians only.

Always give the serial number of the equipment when corresponding or ordering service parts.

Complete repair facilities are maintained by Huck International, Inc. Please contact one of the offices listed below.

Eastern

One Corporate Drive Kingston, New York 12401-0250
Telephone (845) 331-7300 FAX (845) 334-7333

Outside USA and Canada

Contact your nearest Huck International location (see reverse).

In addition to the above repair facilities, there are Authorized Tool Service Centers (ATSC's) located throughout the United States. These service centers offer repair services, spare parts, Service Parts Kits, Service Tool Kits and Nose Assemblies. Please contact your Huck Representative or the nearest Huck International location (see reverse) for the ATSC in your area.



Howmet Inc. (NYSE: HWM) creates breakthrough products that shape industries. Working in close partnership with our customers, we solve complex engineering challenges to transform the way we fly, drive, build and power.

Through the ingenuity of our people and cutting-edge advanced manufacturing, we deliver these products at a quality and efficiency that ensures customer success and shareholder value.

	<p>© 2021 Howmet Aerospace, Inc. Howmet Fastening Systems Kingston Operations</p>
--	---



Huck provides technical assistance regarding the use and application of Huck fasteners and tooling. **NOTICE:** The information contained in this publication is only for general guidance with regard to properties of the products shown and/or the means for selecting such products, and is not intended to create any warranty, express, implied, or statutory; all warranties are contained only in Huck's written quotations, acknowledgments, and/or purchase orders. It is recommended that the user secure specific, up-to-date data and information regarding each application and/or use of such products.

Applifast.



251 Cree Crescent, Winnipeg, MB Canada R3J 3X4
Tel: 204 837 8361 • 1 800 563 1293
info@applifast.com



applifast.com