

POP[®] PB2500



Battery tool for blind rivets

EMHART[®]
TEKNOLOGIES

A StanleyBlack&Decker, Inc. Company

Model		PB2500 (battery)	PB2500 (battery)
Weight	kg [lbs]	1.7 [3.75]	2.0 [4,41]
Length	mm [in]	320 [12.6]	320 [12.6]
Height	mm [in]	240 [9,4]	260 [10,2]
Stroke	mm [in]	25 [0.984]	25 [0.984]
Pulling Force	N [lbf]	8,500 [1911]	8,500 [1911]
Rivet Range	nom. dia.	size 3 (ø 2,4 [3/32"]) thru size 6 (ø 4,8 [3/16"])	

Estimated Rivets per Charge*

Nom. Rivet Dia.	EBC181 battery (18v, 1.5Ah)	EBC180 battery (18v, 3.0Ah)
size 3 ø 2,4 [3/32]	1,300	2,600
size 4 ø 3,2 [1/8]	1,200	2,400
size 5 ø 4,0 [5/32]	1,100	2,200
size 6 ø 4,8 [3/16]	900	1,800

** The values are listed as a guide only and are estimates based on a fully charged battery. Results may vary depending on rivet material, tool/battery condition and work environment.*

© 2013 Emhart Teknologies

All rights reserved.

The information provided may not be reproduced and/or made public in any way and through any means (electronically or mechanically) without prior explicit and written permission from Emhart Teknologies. The information provided is based on the data known at the moment of the introduction of this product. Emhart Teknologies pursues a policy of continuous product improvement and therefore the products may be subject to change. The information provided is applicable to the product as delivered by Emhart Teknologies. Therefore, Emhart Teknologies cannot be held liable for any damage resulting from deviations from the original specifications of the product.

The information available has been composed with the utmost care. However, Emhart Teknologies will not accept any liability with respect to any faults in the information nor for the consequences thereof. Emhart Teknologies will not accept any liability for damage resulting from activities carried out by third parties. The working names, trade names, registered trademarks, etc. used by Emhart Teknologies should not be considered as being free, pursuant to the legislation with respect to the protection of trade marks.

CONTENT

1.	EC-Declaration of Conformity.....	6
2.	Technical Data.....	7
3.	Definitions: Safety Guidelines.....	7
4.	General Power Tool Safety Warnings.....	7
5.	Additional Specific Safety Rules for Blind rivet tools.....	9
6.	Residual Risks.....	9
7.	Markings on Tool.....	9
8.	Important Safety Instructions for All Battery Chargers.....	9
9.	Chargers.....	10
10.	Chargers Procedures.....	10
11.	Charging Process.....	10
12.	Hot/Cold Pack Delay.....	10
13.	Important Safety Instructions for All Battery Packs.....	10
14.	Battery Packs.....	11
15.	Storage Recommendations.....	11
16.	Labels on Charger and Battery Pack.....	11
17.	Package contents.....	12
18.	Description.....	12
19.	Identification of the tool.....	12
20.	Electrical Safety.....	13
21.	Using an Extension Cable.....	13
22.	Assembly & Adjustments.....	13
23.	Inserting and Removing the Battery Pack from the Tool.....	13
24.	Belt Hook and Bit Clip.....	13
25.	Operation - Instructions for Use.....	13
26.	Proper Hand Position.....	13
27.	Tool Setup & Mandrel Collection.....	13
28.	Use.....	14
29.	Cleaning and Maintenance.....	14
30.	Cleaning.....	14
31.	Optional Accessories.....	15
32.	Protecting the Environment.....	15
33.	Rechargeable Battery Pack.....	15
34.	Protect your Investment.....	16
35.	Spare parts - Optional Equipment.....	17
36.	Hints for Quick use.....	20
37.	Trouble shooting guide.....	20

Figure 1

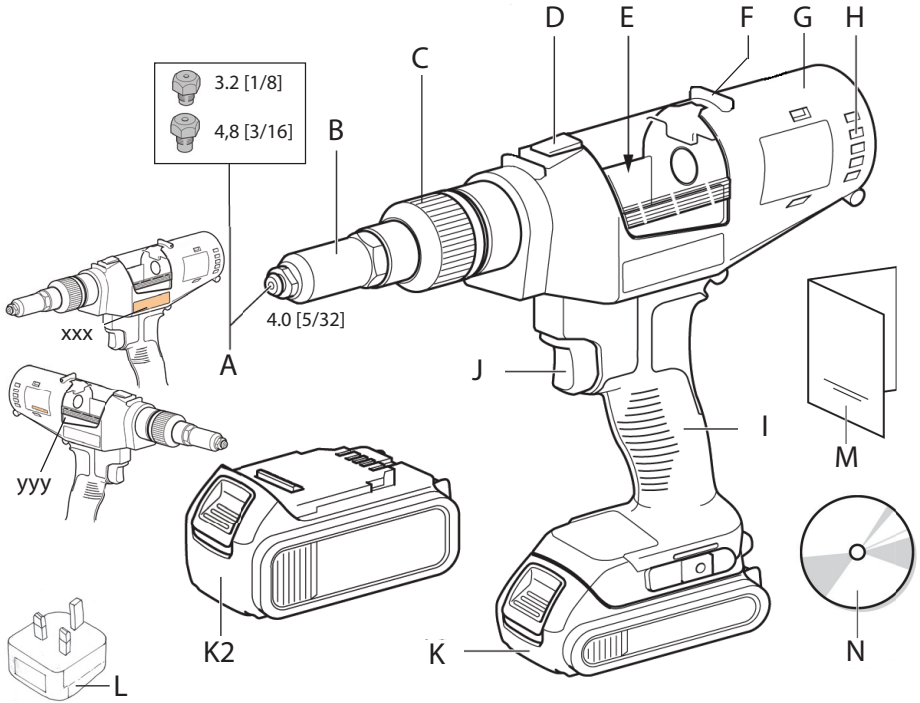

Figure 2

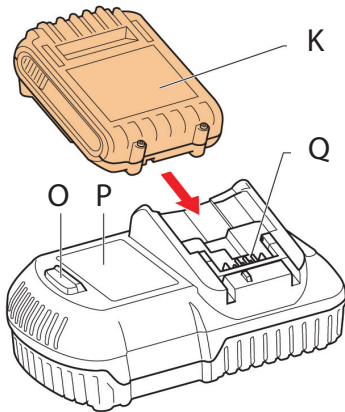

Figure 3

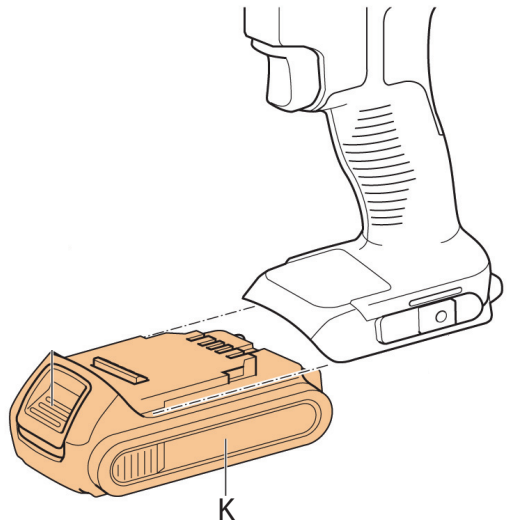

Figure 4

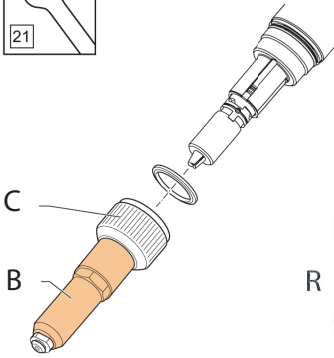

Figure 5

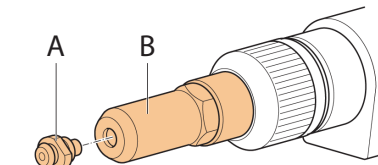
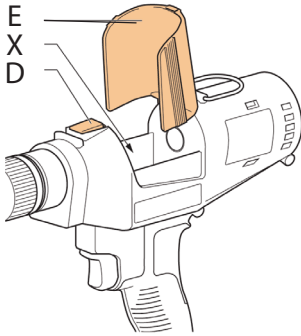
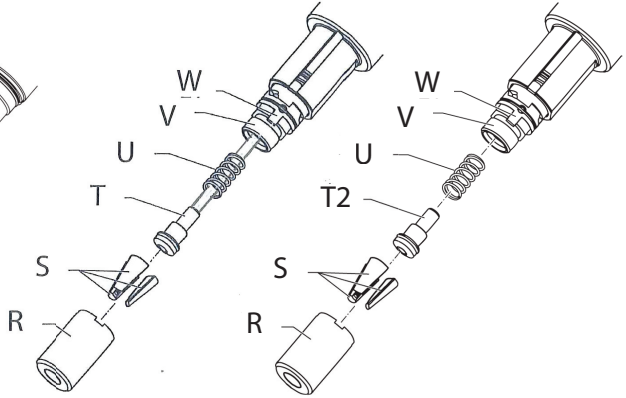

Figure 6

Figure 7

Figure 8

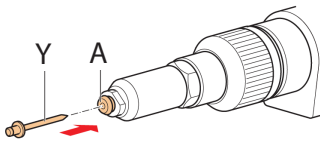

Figure 10

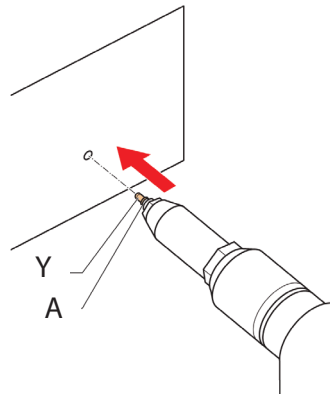
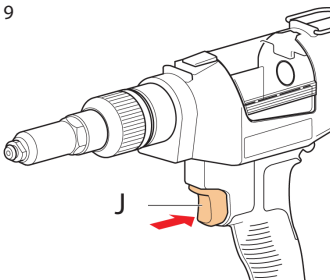

Figure 9





EC Declaration of Conformity .1

Company
Emhart Technologies GmbH
Max-Eyth-Straße 1
35394 Gießen
Germany

No. KFE-PB2500-01

Declare in their sole responsibility that the product:

Battery tool for blind rivets **POP**[®]
Type: PB2500

conforms to all the applicable regulations of the Machinery Directive
The above product follows the provision of the following EC Directives:

2006/42/EC Machinery Directive

2004/108/EC Electromagnetic compatibility

References of directives according to publication in Official Journal of the European Union.

The following harmonised European standards were applied:

• **EN 60745-1:2009**

Hand-held motor-operated electric tools
Safety - Part 1: General requirements.

• **EN 60745-2-2:2010**

Hand-held motor-operated electric tools
Safety - Part 2-2: Particular requirements.

Issued by: Manfred Müller, General Manager

Place, Date: Gießen, 23.01.2013

Legally binding signature:

A handwritten signature in black ink, appearing to be "MM", written over a light grey background.

This declaration certifies compliance with the named Directives.

The safety instructions on the supplied product information sheet are to be followed.

BATTERY TOOL FOR BLIND RIVETS

PB2500

Congratulations!

You have chosen a POP® tool. Years of experience, thorough product development and innovation make POP® one of the most reliable partners for professional blind rivet tool users.

2. Technical data

PB2500		
Voltage	V	18
Type		1
Battery Type		Li-Ion
Weight (without battery pack)	kg	1.35
L_{pa} (sound pressure)	dB(A)	74
K_{pa} (sound pressure uncertainty)	dB(A)	3
L_{pwa} (sound power)	dB(A)	85
K_{pwa} (sound power uncertainty)	dB(A)	3

Vibration total values (tri-ax vector sum) determined according to EN 60745:

Vibration emission value a_h		
$a_h =$	m/s^2	<2.5
Uncertainty $K =$	m/s^2	1.5

The vibration emission level given in this information sheet has been measured in accordance with a standardised test given in EN 60745 and may be used to compare one tool with another. It may be used for a preliminary assessment of exposure.



WARNING: The declared vibration emission level represents the main applications of the tool. However if the tool is used for different applications, with different accessories or poorly maintained, the vibration emission may differ. This may significantly increase the exposure level over the total working period.

An estimation of the level of exposure to vibration should also take into account the times when the tool is not used or when it is running but not actually setting a rivet. This may significantly reduce the exposure level over the total working period.

Identify additional safety measures to protect the operator from the effects of vibration such as: maintain the tool and the accessories, keep the hands warm, organisation of work patterns.

Battery pack	EBC181-NA/	EBC181-QW/
	EBC180-NA	EBC180-QW
Battery type	Li-Ion	Li-Ion
Voltage	V_{DC} 18	18
Capacity	Ah 1.5/3.0	1.5/3.0
Weight	kg 0.35/0.64	0.35/0.64
Charging duration	min 30/60	30/60

Charger	EBC101-NA	EBC105-QW
	Battery Type	Li-Ion
Battery type Mains voltage	V_{AC} 120	230
Input Frequency	Hz 60	50
Weight	kg 0.55	0.55

Fuses

Europe 230 V tools 10 Amperes, mains

3. Definitions: Safety Guidelines

The definitions below describe the level of severity for each signal word. Please read the manual and pay attention to these symbols.



DANGER: Indicates an imminently hazardous situation which, if not avoided, **will result in death or serious injury.**



CAUTION: Indicates a potentially hazardous situation which, if not avoided, **may result in minor or moderate injury.**



WARNING: Indicates a potentially hazardous situation which, if not avoided, **could result in death or serious injury.**

NOTICE: Indicates a practice **not related to personal injury** which, if not avoided, **may result in property damage.**



Denotes risk of electric shock



Denotes risk of fire

4. General Power Tool Safety Warnings



WARNING: To reduce the risk of injury, read the instruction manual.



WARNING! Read all safety warnings and all instructions. Failure to follow the warnings and instructions may result in electric shock, fire and/or serious injury.

SAVE ALL WARNINGS AND INSTRUCTIONS FOR FUTURE REFERENCE

The term “power tool” in the warnings refers to your mains-operated (corded) power tool or battery-operated (cordless) power tool.

4.1) WORK AREA SAFETY

- Keep work area clean and well lit.** Cluttered or dark areas invite accidents.
- Do not operate power tools in explosive atmospheres, such as in the presence of flammable liquids, gases or dust.** Power tools create sparks which may ignite the dust or fumes.
- Keep children and bystanders away while operating a power tool.** Distractions can cause you to lose control.

4.2) ELECTRICAL SAFETY

- Power tool plugs must match the outlet. Never modify the plug in any way. Do not use any adapter plugs with earthed (grounded) power tools.** Unmodified plugs and matching outlets will reduce risk of electric shock.
- Avoid body contact with earthed or grounded surfaces such as pipes, radiators, ranges and refrigerators.** There is an increased risk of electric shock if your body is earthed or grounded.
- Do not expose power tools to rain or wet conditions.** Water entering a power tool will increase the risk of electric shock.
- Do not abuse the cord. Never use the cord for carrying, pulling or unplugging the power tool. Keep cord away from heat, oil, sharp edges or moving parts.** Damaged or entangled cords increase the risk of electric shock.
- When operating a power tool outdoors, use an extension cord suitable for outdoor use.** Use of a cord suitable for outdoor use reduces the risk of electric shock.
- If operating a power tool in a damp location is unavoidable, use a residual current device (RCD) protected supply.** Use of an RCD reduces the risk of electric shock

4.3) PERSONAL SAFETY

- Stay alert, watch what you are doing and use common sense when operating a power tool. Do not use a power tool while you are tired or under the influence of drugs, alcohol or medication.** A moment of inattention while operating power tools may result in serious personal injury.
- Use personal protective equipment. Always wear eye protection.** Protective equipment such as dust mask, non-skid safety shoes, hard hat, or hearing protection used for appropriate conditions will reduce personal injuries.
- Prevent unintentional starting. Ensure the switch is in the off-position before connecting**

to the power source and/or battery pack, picking up or carrying the tool. Carrying power tools with your finger on the switch or energising power tools that have the switch on invites accidents.

- Remove any adjusting key or wrench before turning the power tool on.** A wrench or a key left attached to a rotating part of the power tool may result in personal injury.
- Do not overreach. Keep proper footing and balance at all times.** This enables better control of the power tool in unexpected situations.
- Dress properly. Do not wear loose clothing or jewellery. Keep your hair, clothing and gloves away from moving parts.** Loose clothes, jewellery or long hair can be caught in moving parts.

4.4 POWER TOOL USE AND CARE

- Do not force the power tool. Use the correct power tool for your application.** The correct power tool will do the job better and safer at the rate for which it was designed.
- Do not use the power tool if the switch does not turn it on and off.** Any power tool that cannot be controlled with the switch is dangerous and must be repaired.
- Disconnect the plug from the power source and/or the battery pack from the power tool before making any adjustments, changing accessories, or storing power tools.** Such preventive safety measures reduce the risk of starting the power tool accidentally.
- Store idle power tools out of the reach of children and do not allow persons unfamiliar with the power tool or these instructions to operate the power tool.** Power tools are dangerous in the hands of untrained users.
- Maintain power tools. Check for misalignment or binding of moving parts, breakage of parts and any other condition that may affect the power tool's operation. If damaged, have the power tool repaired before use.** Many accidents are caused by poorly maintained power tools
- Keep cutting tools sharp and clean.** Properly maintained cutting tools with sharp cutting edges are less likely to bind and are easier to control.
- Use the power tool, accessories and tool bits etc., in accordance with these instructions taking into account the working conditions and the work to be performed.** Use of the power tool for operations different from those intended could result in a hazardous situation.

4.5) BATTERY TOOL USE AND CARE

- Recharge only with the charger specified by the manufacturer.** A charger that is suitable for

one type of battery pack may create a risk of fire when used with another battery pack.

- b) **Use power tools only with specifically designated battery packs.** Use of any other battery packs may create a risk of injury and fire.
- c) **When battery pack is not in use, keep it away from other metal objects like paper clips, coins, keys, nails, screws or other small metal objects that can make a connection from one terminal to another.** Shorting the battery terminals together may cause burns or a fire.
- d) **Under abusive conditions, liquid may be ejected from the battery, avoid contact. If contact accidentally occurs, flush with water. If liquid contacts eyes, additionally seek medical help. Liquid ejected from the battery may cause irritation or burns.**

4.6) SERVICE

- a) **Have your power tool serviced by a qualified repair person using only identical replacement parts.** This will ensure that the safety of the power tool is maintained.

5. Additional Specific Safety Rules for Blind rivet tools

- **Hold power tool by insulated gripping surfaces when performing an operation where the fastener may contact hidden wiring.** Fasteners contacting a "live" wire may make exposed metal parts of the power tool "live" and could give the operator an electric shock.

6. Residual Risks

In spite of the application of the relevant safety regulations and the implementation of safety devices, certain residual risks cannot be avoided. These are:

- Impairment of hearing.
- Risk of personal injury due flying particles
- Risk of burns due to accessories becoming hot during operation.
- Risk of personal injury due to prolonged use.

7. Markings on Tool

The following pictograms are shown on the tool:



Read instruction manual before use.



Discard the tools with due care for the environment.

DATE CODE POSITION

The Date Code, which also includes the year of manufacture, is printed into the housing surface that forms the mounting joint between tool and battery.

Example:

XXXXX

8. Important Safety Instructions for All Battery Chargers

SAVE THESE INSTRUCTIONS: This manual contains important safety and operating instructions for the EBC105 battery charger.

- Before using the charger, read all instructions and cautionary markings on charger, battery pack and product using the battery pack



WARNING: Shock hazard. Do not allow any liquid to get inside charger. Electric shock may result.



Caution: Burn hazard. To reduce the risk of injury, charge only POP® rechargeable battery packs. Other types of batteries may overheat and burst resulting in personal injury and property damage.



CAUTION: Children should be supervised to ensure that they do not play with the appliance.

NOTICE: Under certain conditions, with the charger plugged in to the power supply, the exposed charging contacts inside the charger can be shorted by foreign material. Foreign materials of a conductive nature such as, but not limited to, steel wool, aluminium foil or any build-up of metallic particles should be kept away from charger cavities. Always unplug the charger from the power supply when there is no battery pack in the cavity. Unplug charger before attempting to clean.

- **DO NOT attempt to charge the battery pack with any chargers other than the ones in this manual.** The charger and battery pack are specifically designed to work together.
- **These chargers are not intended for any uses other than charging POP® rechargeable batteries.** Any other uses may result in risk of fire, electric shock or electrocution.
- **Do not expose charger to rain or snow. Pull by plug rather than cord when disconnecting charger.** This will reduce risk of damage to electric plug and cord.
- **Make sure that cord is located so that it will not be stepped on, tripped over or otherwise subjected to damage or stress. Do not use an**

extension cord unless it is absolutely necessary. Use of improper extension cord could result in risk of fire, electric shock or electrocution.

- **When operating a charger outdoors, always provide a dry location and use an extension cord suitable for outdoor use.** Use of a cord suitable for outdoor use reduces the risk of electric shock.
- **Do not block the ventilation slots on the charger.** The ventilation slots are located on the top and sides of the charger. Place the charger in a position away from any heat source.
- **Do not operate charger with damaged cord or plug** — have them replaced immediately.
- **Do not operate charger if it has received a sharp blow, been dropped or otherwise damaged in any way.** Take it to an authorised service centre.
- **Do not disassemble the charger; take it to an authorised service centre when service or repair is required.** Incorrect reassembly may result in a risk of electric shock, electrocution or fire.
- In case of damaged power supply cord the supply cord must be replaced immediately by the manufacturer, its service agent or similar qualified person to prevent any hazard.
- **Disconnect the charger from the outlet before attempting any cleaning. This will reduce the risk of electric shock.** Removing the battery pack will not reduce this risk.
- **NEVER** attempt to connect 2 chargers together.
- **The charger is designed to operate on the voltage specified in the Charger Specifications chart. Do not attempt to use it on any other voltage.** Refer to your Charger Model No. for the correct specification.

SAVE THESE INSTRUCTIONS

9. Chargers

The EBCB105 charger accepts EBC181 & EBC180, 18 V Li-Ion battery packs.

This charger requires no adjustment and is designed to be as easy as possible to operate.

10. Charging Procedures (fig. 2)





1. Plug the charger into an appropriate outlet before inserting the battery pack. (Refer to the Charger Specifications)
2. Insert the battery pack (K) into the charger, making sure the pack is fully seated in the charger. The red (charging) light will blink continuously indicating that the charging-process has started.

3. The completion of charge will be indicated by the red light remaining ON continuously. The pack is fully charged and may be used at this time or left in the charger.

NOTE: To ensure maximum performance and life of Li-Ion battery packs, charge the battery for a minimum of 10 hours before first use.

11. Charging Process

Refer to the table below for the state of charge of the battery pack.

State of charge	
 charging	-----
 fully charged	-----
 hot/cold pack delay	---.---.---
 problem pack or charger
 problem power line

This charger will not charge a faulty battery pack. The charger will indicate faulty battery by refusing to light or by displaying problem pack or charger blink pattern.

NOTE: This could also mean a problem with a charger.

If the charger indicates a problem, take the charger and battery pack to be tested at an authorised service centre.

12. Hot/Cold Pack Delay

When the charger detects a battery that is too hot or too cold, it automatically starts a hot/cold pack delay, suspending charging until the battery has reached an appropriate temperature. The charger then automatically switches to the pack charging mode. This feature ensures maximum battery life. Emhart Li-Ion tools are designed with an Electronic Protection System that will protect the battery against overloading, overheating or deep discharge. The tool will automatically turn off if the Electronic Protection System engages. If this occurs, place the Li-Ion battery on the charger until it is fully charged. A cold battery pack will charge at about half the rate of a warm battery pack. The battery pack will charge at that slower rate throughout the entire charging cycle and will not return to maximum charge rate even if the battery warms.

13. Important Safety Instructions for All Battery Packs

When ordering replacement battery packs, be sure to include the catalogue number and voltage.

The battery pack is not fully charged out of the carton. Before using the battery pack and charger, read the safety instructions below and then follow the charging procedures outlined.

READ ALL INSTRUCTIONS

- **Do not charge or use the battery pack in explosive atmospheres, such as in the presence of flammable liquids, gases or dust.** Inserting or removing the battery pack from the charger may ignite the dust or fumes.
- **Never force the battery pack into charger. Do not modify the battery pack in any way to fit into a non-compatible charger as battery pack may rupture causing serious personal injury.**
- Charge the battery packs only in designated POP® chargers.
- **DO NOT splash or immerse in water or other liquids.**
- **Do not store or use the tool and battery pack in locations where the temperature may reach or exceed 40 °C (105 °F) (such as outside sheds or metal buildings in summer).**
- For best results, make sure the battery pack is fully charged before use.



WARNING: Never attempt to open the battery pack for any reason. If the battery pack case is cracked or damaged, do not insert it into the charger. Do not crush, drop or damage battery pack. Do not use a battery pack or charger that has received a sharp blow, been dropped, run over or damaged in any way (e.g., pierced with a nail, hit with a hammer, stepped on). Electric shock or electrocution may result. Damaged battery packs should be returned to the service centre for recycling.



Caution: When not in use, place tool on its side on a stable surface where it will not cause a tripping or falling hazard. Some tools with large battery packs will stand upright on the battery pack but may be easily knocked over.

SPECIFIC SAFETY INSTRUCTIONS FOR LITHIUM ION (LI-ION)

- **Do not incinerate the battery pack even if it is severely damaged or is completely worn out.** The battery pack can explode in a fire. Toxic fumes and materials are created when lithium ion battery packs are burned.
- **If battery contents come into contact with the skin, immediately wash the area with mild soap and water.** If the battery liquid gets into the eye, rinse water over the open eye for 15 minutes or until irritation ceases. If medical attention is needed, the

battery electrolyte is composed of a mixture of liquid organic carbonates and lithium salts.

- **Contents of opened battery cells may cause respiratory irritation.** Provide fresh air. If symptoms persist, seek medical attention.



WARNING: Burn hazard. Battery liquid may be flammable if exposed to spark or flame.

14. Battery Packs

BATTERY TYPE

The PB2500 operates on 18 volt battery pack. EBC180 & EBC181 battery packs may be used. Refer to Technical Data for more information.

15. Storage Recommendations

1. The best storage place is one that is cool and dry away from direct sunlight and excess heat or cold. For optimum battery performance and life, store battery packs at room temperature when not in use.
2. For long storage, it is recommended to store a fully charged battery pack in a cool, dry place out of the charger for optimal results.

NOTE: Battery packs should not be stored completely depleted of charge. The battery pack will need to be recharged before use.

16. Labels on Charger and Battery Pack

In addition to the pictographs used in this manual, the labels on the charger and the battery pack show the following pictographs.



Read instruction manual before use.



Battery charging.



Battery charged.



Hot/cold pack delay.



Problem pack or charger.



Problem power line.



Do not probe with conductive objects.



Do not charge damaged battery packs.



Use only with POP® battery packs. Others may burst causing personal injury and damage.



Do not expose to water.



Have defective cords replaced immediately.



Charge only between 4 °C and 40 °C.



Discard the battery pack with due care for the environment.



Do not incinerate the battery pack.



Charges Li-Ion battery packs.



See Technical Data for charging time.



Only for indoor use.

17. Package contents

The package contains:

- 1 PB2500 tool with nose piece size \varnothing 4,8[3/16]
- 1 Charger 20V max.
- 1 Battery 18V Lithium Ion
- 1 Converter Plug for the UK (European tools only)
- 1 Bag with nose piece and matching jaw pusher assembly extended tube size 4 (\varnothing 3,2 [1/8])
- 1 Bag with nose piece and matching jaw pusher assembly extended tube size 5 (\varnothing 4,0 [5/32])
- 1 Instruction Manual

NOTE:

- Check for damage to the tool, parts or accessories which may have occurred during transport.
- Take the time to thoroughly read and understand this manual prior to operation.

18. Description (fig. 1)



WARNING: Never modify the power tool or any part of it. Damage or personal injury could result.

Components Fig. 1&2

A. Nose Pieces

- B. Nose housing
- C. Nose housing nut
- D. Collector lock
- E. Collector shutter
- F. Shutter guide sleeve
- G. Motor housing
- H. Exhaust vent
- I. Handle
- J. Switch
- K. Battery Pack 1.5 Ah
- K2. Battery Pack 3.0 Ah
- L. Conversion plug
- M. Manual
- N. CD
- O. Charger lamp
- P. Charger

Components Fig. 4&5

- Q. Battery charger connection
- R. Jaw guide
- S. Jaws
- T. Jaw pusher with extended tube size 4 (\varnothing 3,2 [1/8]) or size 5 (\varnothing 4,0 [5/32])
- T2. Jaw pusher size 6 (\varnothing 4,8 [3/16])
- U. Spring
- V. Pulling Head
- W. Font Clutch (Jaw case lock)
- X. Mandrel collector
- Y. Blind rivet

19. Identification of the tool

- xxx Model number
- yyy Serial number

INTENDED USE

This blind riveting power tool is designed for professional blind rivet setting applications.

DO NOT use under wet conditions or in presence of flammable liquids or gases.

This blind riveter is a professional power tool.

DO NOT let children come into contact with the tool. Supervision is required when inexperienced operators use this tool.

- This product is not intended for use by persons (including children) suffering from diminished physical, sensory or mental abilities, or for lack of experience and/or for want of knowledge

or skills unless they are supervised by a person responsible for their safety. Children should never be left alone to play with this product.

20. Electrical Safety

The electric motor has been designed for one voltage only. Always check that the battery pack voltage corresponds to the voltage on the rating plate. Also make sure that the voltage of your charger corresponds to that of your mains.



Your POP® charger is double insulated in accordance with EN 60335; therefore no earth wire is required.

If the supply cord is damaged, it must be replaced by a specially prepared cord available through the POP® service organisation.

21. Using an Extension Cable

An extension cord should not be used unless absolutely necessary. Use an approved extension cable suitable for the power input of your charger (*see technical data*). The minimum conductor size is 1.5 mm²; the maximum length is 30 m. When using a cable reel, always unwind the cable completely.

22. ASSEMBLY & ADJUSTMENTS



WARNING: Prior to assembly and adjustment, always remove the battery pack. Always switch off the tool before inserting or removing the battery pack.



WARNING: Use only POP® battery packs and chargers.

23. Inserting and Removing the Battery Pack from the Tool (fig. 3)

NOTE: For best results, make sure your battery pack is fully charged. The light will shut off without warning when the battery is fully discharged.

TO INSTALL THE BATTERY PACK INTO THE HANDLE

1. Align the battery pack (K) with the rails inside the tool's handle (fig. 3).
2. Slide it into the handle until the battery pack is firmly seated in the tool and ensure that it does not disengage.

TO REMOVE THE BATTERY PACK FROM THE HANDLE

1. Press battery release button and firmly pull the battery pack out of the tool handle.

2. Insert battery pack into the charger as described in the charger section for this manual.

24. Belt Hook and Bit Clip



WARNING: To reduce the risk of serious personal injury, **DO NOT** suspend tool overhead or suspend objects from the belt hook. **ONLY** hang tool's belt hook from a work belt.



WARNING: To reduce the risk of serious personal injury, ensure the screw holding the belt hook is secure.

IMPORTANT: When attaching or replacing the belt hook or bit clip, use only the screw that is provided. Be sure to securely tighten the screw. The belt hook and bit clip can be attached to either side of the tool using only the screw provided, to accommodate left- or right-handed users. If the hook or bit clip is not desired at all, it can be removed from the tool. To move belt hook or bit clip, remove the screw that holds it in place then reassemble on the opposite side. Be sure to securely tighten the screw.

25. OPERATION

Instructions for Use



WARNING: Always observe the safety instructions and applicable regulations.



WARNING: To reduce the risk of serious personal injury, **disconnect battery pack before making any adjustments or removing/installing attachments or accessories.**

26. Proper Hand Position



WARNING: To reduce the risk of serious personal injury, **ALWAYS** use proper hand position.



WARNING: To reduce the risk of serious personal injury, **ALWAYS** hold securely in anticipation of a sudden reaction.

Proper hand position requires one hand on the main handle fig. 1- (I).

27. Tool Setup & Mandrel Collection



WARNING: Before adjusting tool, always remove the battery pack.

Opening and closing the mandrel collector (fig. 6)

- The mandrel collector is used to collect the rest mandrel. To open the mandrel collector (X), slide the release button (D) towards the nose housing nut (C) and raise the cover (E).

- To close the the mandrel collector (X), lower the cover (E) until the release button (D) clicks into place.

Mounting the nosepiece (fig. 7)

- The tool is supplied with various nose pieces. The available nosepieces are: size 4 (ø 3.2 mm [1/8"]); size 5 (ø 4.0 mm [5/32"]); size 6 (ø 4.8 mm [3/16"]).
- Select the correct nosepiece A.
- Tighten the nosepiece into the front sleeve. (B) by turning it clockwise using 11 mm spanner.

Mounting the jaw pusher (fig. 5)

- In addition to nosepieces, the tool is supplied with various jaw pushers (T, T2) to be selected in conjunction to nosepieces selection in the above section (for reference, correct set is to match both nosepiece and jaw pusher internal hole diameters). Using the appropriate jaw pusher is mandatory in order to guarantee all mandrels to be correctly exhausted into the Mandrel Collector System.
- Select the correct jaw pusher or jaw pusher assembly (T, T2).
- Insert small tube diameter into jaw pusher spring.
- Reassemble jaw set (S) and jaw case (R) onto jaw case lock (W)
- Note: Avoid spanners to mount jaw case (R) onto jaw case lock (W). Jaw case (R) manual tightening is enough to lock jaw case (R) onto front clutch (W)

28. Use

Place the rivet (fig. 8)

Place the blind rivet (Y) in the nose piece (A)

Position the tool (fig.10)

Switch operation (fig. 9)

- Pull and hold the switch (J) until the rivet is fully set in the application.
- If you release the switch (J) before the end of the setting stroke, the tool will immediately return to its initial position. If the blind rivet (Y) has not been set completely, repeat the previous steps.
- If the blind rivet (Y) has been set completely, release the switch (J). The tool will return to its initial position automatically. The mandrel is automatically dropped into the mandrel collector (X).

Reset function (fig.9)

If the tool does not move to its initial position after releasing the switch or stops during the setting stroke, reset the tool to home by quickly pulling and

releasing the switch (J). If this does not work review the Troubleshooting Guide.

29. Cleaning and Maintenance



WARNING: Before cleaning and maintenance, always remove the battery pack.

- Keep the ventilation openings free from dust and dirt. If necessary, use a soft, moist cloth to remove dust and dirt from the ventilation openings.

Emptying the mandrel collector

The mandrel collector must be emptied depending on the size of the blind rivets used.

Nom. Rivet Dia.	Approx. Capacity
2.4 mm [3/32"]	600
3.2 mm [1/8"]	360
4.0 mm [5/32"]	200
4.8 mm [3/16"]	150

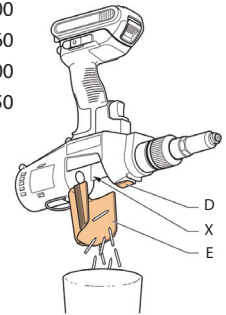

- Open the mandrel collector (X).
- Hold the tool upside down above a dustbin to empty the mandrel collector (X).
- Close the mandrel collector (X).



30. Cleaning



WARNING: Blow dirt and dust out of the main housing with dry air as often as dirt is seen collecting in and around the air vents. Wear approved eye protection and approved dust mask when performing this procedure.



WARNING: Never use solvents or other harsh chemicals for cleaning the non-metallic parts of the tool. These chemicals may weaken the materials used in these parts. Use a cloth dampened only with water and mild soap. Never let any liquid get inside the tool; never immerse any part of the tool into a liquid.

CHARGER CLEANING INSTRUCTIONS



WARNING: Shock hazard. Disconnect the charger from the AC outlet before cleaning. Dirt and grease may be removed from the exterior of the charger using a cloth or soft non-metallic brush. Do not use water or any cleaning solutions.

Cleaning the Nose Housing & Jaw Case (fig. 4 & 5)

- Loosen the nose housing nut (C). Remove the nose housing (B).
- Press the jaw case lock (W) and loosen the jaw guide (R). Release the jaw case lock (W).
- Remove the jaws (S) and the jaw pusher (T).
- Remove the spring (U).
- Clean the inside of the nose housing (B) using a dry cloth.
- Clean the clamping jaws (S) and the jaw pusher (T) using a dry cloth. If necessary, replace the jaws (S) and the jaw pusher (T).
- Clean the pulling head (V) using a dry cloth.
- Apply grease to the inside of the jaw guide (R) where the jaws (S) make contact. A Molybdenum Disulfide based grease is recommended.
- Mount the spring (U).
- Mount the jaw pusher (T) and the jaws (S).
- Press the jaw case lock (W) and tighten the jaw guide (R). Release the jaw case lock (W).
- Mount the nose housing (B). Tighten the nose housing nut (C).

31. Optional Accessories



WARNING: Since accessories, other than those offered by POP® have not been tested with this product, use of such accessories with this tool could be hazardous. To reduce the risk of injury, only POP® recommended accessories should be used with this product.

Consult your dealer for further information on the appropriate accessories.



WARNING: To reduce the risk of serious personal injury, disconnect battery pack before making any adjustments or removing/installing attachments or accessories.

Maintenance Frequency

Item	Frequency
Clean & lubricate Nose Housing & Jaw Case	5,000 rivets
Clean & grease Ball Screw and Thrust Bearing	50,000 rivets*

*Recommend contacting authorized service centre

32. Protecting the Environment



Separate collection. This product must not be disposed of with normal household waste.



Should you find one day that your POP® product needs replacement, or if it is of no further use to you, do not dispose of it with household waste. Make this product available for separate collection.



Separate collection of used products and packaging allows materials to be recycled and used again. Re-use of recycled materials helps prevent environmental pollution and reduces the demand for raw materials.

Local regulations may provide for separate collection of electrical products from the household, at municipal waste sites or by the retailer when you purchase a new product.

You can check the location of your nearest authorised repair agent by contacting your local POP® office at the address indicated in this manual. Alternatively, a list of authorised POP® repair agents and full details of our after-sales service and contacts are available on the Internet at: www.emhart.com.



33. Rechargeable Battery Pack

This long life battery pack must be recharged when it fails to produce sufficient power on jobs which were easily done before. At the end of its technical life, discard it with due care for our environment:

- Run the battery pack down completely, then remove it from the tool.
- Li-Ion cells are recyclable. Take them to your dealer or a local recycling station. The collected battery packs will be recycled or disposed of properly.

34. Protect your Investment! Register Your Rivet Tool.

POP® RIVET TOOL WARRANTY

Emhart Teknologies warrants that all power tools have been carefully manufactured and that they will be free from defect in material and workmanship under normal use and service for a period of one (1) year. This warranty applies to the first time purchaser of the tool for original use only.

Exclusions:

Normal wear and tear. Periodic maintenance, repair and replacement parts due to normal wear and tear are excluded from coverage.

Abuse & Misuse. Defect or damage that results from improper operation, storage, misuse or abuse, accident or neglect, such as physical damage are excluded from coverage.

Unauthorized Service or Modification. Defects or damages resulting from service, testing adjustment, installation, maintenance, alteration or modification in any way by anyone other than Emhart Teknologies, or its authorized service centres, are excluded from coverage.

All other warranties, whether expressed or implied, including any warranties of merchantability or fitness for purpose are hereby excluded.

Should this tool fail to meet the warranty, promptly return the tool to our factory authorized service centre location nearest you. For a list of POP Authorized Service Centres in the US or Canada, contact us at our toll free number (877)EMHART1.

Outside the US and Canada, visit our website **www.emhart.com** to find your nearest Emhart Teknologies location.

Emhart Teknologies will then replace, free of charge, any part or parts found by us to be defective due to faulty material or workmanship, and return the tool prepaid. This represents our sole obligation under this warranty. In no event shall Emhart Teknologies be liable for any consequential or special damages arising out of the purchase or use of this tool.

To register your warranty online, visit us <http://www.emhartamericas.com/pop-powertools/warranty-card>. Thank you for choosing an Emhart Teknologies' POP® Brand tool.

35. Spare Parts - Tool

Int'l Part No.	Description	Fig. reference
TP124-542	SA Nosepiece, 6 Size (4,8 mm - 1/16")	Fig.1. item A
DPN275-001	Jaw Guide	Fig. 5. item R
13300	Jaws - One Set (3)	Fig. 5. item S
TP124-549	SA Jaw Pusher, 6	Fig. 5. item T2
TP114-652	Jaw Pusher Spring	Fig. 5. item U
TP114-676	Shutter Guide Sleeve	Fig. 1. item F
TP123-531	Collector Shutter	Fig. 1. item E
TP124-540	SA Nosepiece, 4 size (3,2 mm - 1/8")	Fig. 1. item A
TP124-541	SA Nosepiece, 5 size (4,0 mm - 5/32")	Fig. 1. item A
TP124-635	Jaw Pusher Assembly, 4 size (3,2 mm - 1/8")	Fig. 5. item T
TP124-548	Jaw Pusher Assembly, 5 size (4,0 mm - 5/32")	Fig. 5. item T

Optional Equipment - Tool

Int'l Part No.	Description
TP124-539	SA Nosepiece, 3 size (2,4 mm - 3/32")
TP124-547	Jaw Pusher 3 size (2,4 mm - 3/32")
PRG540-46B	Jaws for 3 size (2,4 mm - 3/32") and recommended for setting 4, 5 size Stainless steel
TP124-618	Jaw Pusher Assembly for use with PRG540-46B for setting 5 size Stainless steel
TP124-638	Jaw Pusher Assembly for use with PRG540-46B for setting 4 size Stainless steel
PNT600-132	Hook PB2500
TP134-500	Belt Hook kit

Battery and Charger

Int'l Part No.	Description	
EBC181-NA		
EBC181-QW	18 V 1.5 Ah PB2500 Battery	Fig. 1 item K
EBC180-NA		
EBC180-QW	18 V 3.0 Ah PB2500 Battery	Fig. 1 item K2
EBC101-NA		
EBC105-QW	PB2500 Charger	Fig. 2 item P

Europe

The Netherlands

Emhart Teknologies B.V.

P.O. Box 70
6120 AB Born
The Netherlands
Tel. +31 43 750 2023
Fax +31 43 750 2030
popnl@sbdinc.com

United Kingdom

Emhart Teknologies

177 Walsall Road
Birmingham, B42 1BP
United Kingdom
Tel. +44 121 356 4811
Fax +44 121 356 1598
popuk@sbdinc.com

Spain

Emhart Teknologies

Sistemas de Fijacion Tucker
Carretera M-300
KM.29, 700
28802, Alcalá de Henares
Madrid, Spain
Tel. +34 91 887 1470
Fax +34 91 882 3602
popes@sbdinc.com

France

Emhart Teknologies

Emhart SNC
Zone Immparc
Route de Chartres, Bât Loire 4
78190 Trappes, France
Tel. +33 1 30 50 91 00
Fax +33 1 30 51 07 08
popfr@sbdinc.com

Germany

Emhart Teknologies

Tucker Fasteners GmbH
Max-Eyth-Strasse 1
D-35394 Giessen
Germany
Tel. +49 641 405 0
Fax +49 641 405 366
popde@sbdinc.com

Norway

Emhart Teknologies

Emhart Sjong
PO Box 203
Skjutbanevägen 6
S-701 44 Örebro
Sweden
Tel. +47 22 90 99 90
popno@sbdinc.com
info@emhart-teknik.se

Denmark

Emhart Teknologies

Emhart Harttund A/S
Roskildevej 22
DK-2620 Albertslund
Denmark
Tel. +45 44 84 11 00
Fax +45 44 84 62 12
popdk@sbdinc.com
salg.danmark@bdk.com

Sweden

Emhart Teknologies

Emhart Teknik AB
PO Box 203
Skjutbanevägen 6
S-701 44 Örebro
Sweden
Tel. +46 19 20 58 00
Fax +46 19 26 00 38
popse@sbdinc.com
info@emahrt-teknik.se

Finland

Emhart Teknologies

Stanley Black & Decker Finland
Oy
Kumpulnatie 13B, PL 47
FI-00521 Helsinki
Finland
Tel. +358 9 819 0060
Fax +358 9 812 428
popfi@sbdinc.com
myynti.emhart@bdk.com

Czech Republic

Emhart Teknologies

Tucker s.r.o.
Tel. +420 725 800 454
Fax +420 493 546 567

Poland

Emhart Teknologies

Masterfix Poland LTD
ul. Daleka 16
60-124 Ponań, Poland
Tel. +48 61 86 66 297
Fax +48 61 86 65 733
poppl@sbdinc.com

Americas

USA - Connecticut

Emhart Teknologies

4 Corporate Drive, Suite 395
Shelton, CT 06484
USA
Tel. +1 203 925 2260
Fax +1 203 925 2279

Canada

Emhart Teknologies

9870 Boulevard Du Golf
Anjou, Quebec
Canada H1J 2Y7
Tel. +1 514 351 0330
Fax +1 514 351 0458

Mexico

Emhart Teknologies

Bosque De cidros
Acceso Eadiatas No 42
Bosque De Las Lomas,
3a Sexxion, Mexico City
Mexico DF 05120
Tel. +52 55 5326 7100
Fax +52 55 5236 7141

Brazil

Emhart Teknologies

Emhart Refal
Rua Ricardo Cavatton, 226
CEP: 05038-110 São Paulo
Brazil
Tel. +52 55 11 3871 6460
Fax +52 55 11 3611 3505

Asia

China

Emhart Teknologies

Shanghai Emhart Fastening
Systems
488 Jialou Road
Jaiding District
Shanghai 201807, China
Tel. +86 21 5954 8626
Fax +86 21 5954 8775

Japan

Emhart Teknologies

Shuwa Kioicho Park Building
302
3-6 Kioicho, Chiyoo-Ku
Tokyo, 1020094, Japan
Tel. +81 3 3265 7291
Fax +81 3 3265 7298

Korea

Emhart Teknologies

Seorin Building
45-15 Yeoido-Dong
Yeongdeungpo-Ku
Seoul, 150-891, R.O. Korea
Tel. +82 2 783 9226
Fax +82 2 783 9228

India

Emhart Teknologies

APEX Towers, 5th Floor
No 54, 2nd Main Road
R.A. Puram, Chennai-600028
India
Tel. +91 44 4306 0639
Fax +91 44 4306 0768

As a result of our continuous design improvement, Emhart products are subject to modification. The latest technical data and drawings, as well as the latest version of this manual is available to view and download at www.emhartmedia.com

USB with manual in other European languages

Only for QW sets sold in Europe

Operating instructions are available on this USB in other European languages. If for whatever reason you cannot read the USB or do not have the means to open the USB, please contact us and we will send you a paper copy in the language requested.

Do not use tool before first heaving read the complete operating instructions!



36. Hints for Quick use

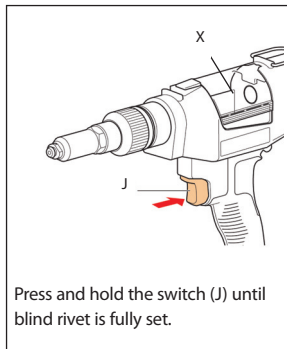
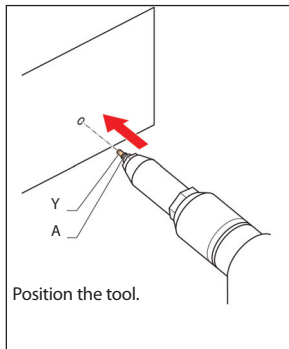
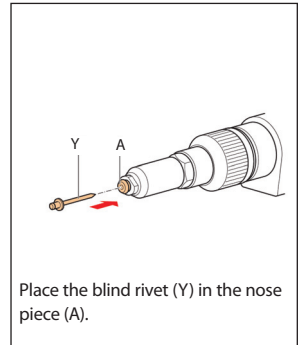
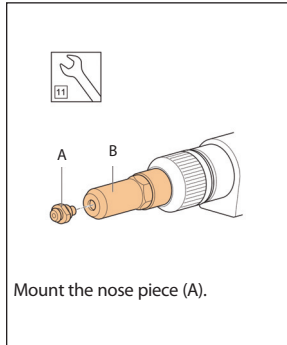
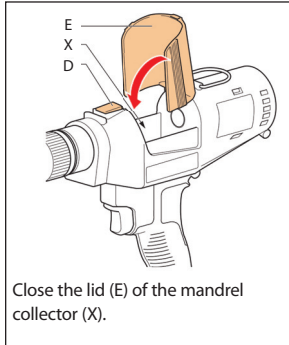

- If the blind rivet (Y) has not been set completely, repeat the previous steps.
- If the blind rivet (Y) has been set completely, release the switch (J). The mandrel will automatically fall into the mandrel collector (X).

37. Trouble shooting guide

Symptom	Cause	Remedy
Tool stops before rivet is fully set	Setting load of rivet is beyond tool capacity.	Reset tool to home, remove rivet & use appropriate tool to set rivet.
	Improper nosepiece selection.	Reset tool to home, remove rivet & fit proper nose piece.
	Battery pack has reached operating temperature limit through continuous use or defect.	Remove battery & allow to cool. Mount battery and reset tool to home.
Tool does not return to initial position when switch is released.	Electrical malfunction.	Remove battery, wait 5 seconds and reinsert. Reset tool to home.
Tool does not operate when switch is pressed.	Battery is not fully seated	Remove battery and re-insert. Reset tool to home.
	Battery is not fully charged	Charge battery
	Battery pack has reached operating temperature limit through continuous use or defect.	Remove battery & allow to cool. Mount battery and reset tool to home.
	Battery is defective	Replace battery

*Reset tool to home: quickly pull & release the switch

Applifast.

251 Cree Crescent, Winnipeg, MB Canada R3J 3X4
Tel: 204 837 8361 • 1 800 563 1293
Fax: 204 837 3520 • 1 800 974 1494



applifast.com