



**HOWMET
AEROSPACE**

Huck-Spin[®] 2

The Huck-Spin Fastener,
Evolved



The Huck-Spin® 2

All the Vibration-Resistant Advantages of Huck-Spin®, and Much More

It's a whole new spin on fastening for high-volume OEM applications, heavy-assembly, and aftermarket repair.

Offering the high-performance characteristics of the classic Huck-Spin® fastener that you've come to rely on, the Huck-Spin 2 brings even more performance to every job. Because of its unique engineering and design, the Huck-Spin 2 delivers higher speed of installation than Huck-Spin, saving two to three seconds per installed fastener. Huck-Spin 2 promotes longer tool life because the thimbles last three to four times longer than original Huck-Spin thimbles in factory environments. And, Huck-Spin 2 means less tool maintenance – the lower hydraulic pressure needed leads to longer lasting

seals and hoses. While the Huck-Spin 2 is a more advanced version, it retains all the benefits of the original Huck-Spin. For instance, it features a low-impact, straight-line installation process, delivering a highly secure joint, each and every time. Huck-Spin 2 still retains a high clamp load, delivering up to eight times greater fatigue strength than conventional nuts and bolts. In addition, the Huck-Spin 2, like the original Huck-Spin, is designed with no pintail, so you can count on improved factory safety, reduced noise levels, and less impact on your Huck tooling. Greater productivity. Reduced maintenance. Increased installation speed. Get it all in the Huck-Spin 2.

- ✓ Easier installation due to reduced diameter pilot point.
- ✓ Less interference with collar tab during fit-up because of deeper bolt lock groove.
- ✓ Less likely to have “spinners” due to left-handed pull threads: thimbles can be pushed uphill onto the puller thread.
- ✓ Takes less than half of the revolutions to spin-on and spin-off because of double-helix pull grooves.
- ✓ Save two-to-three seconds installation time per installed fastener.
- ✓ Huck-Spin 2 thimbles last three to four times longer than Huck-Spin thimbles in factory environments.
- ✓ Huck-Spin 2 requires lower hydraulic pressure compared to the Huck-Spin, so seals, hoses and tools last longer.

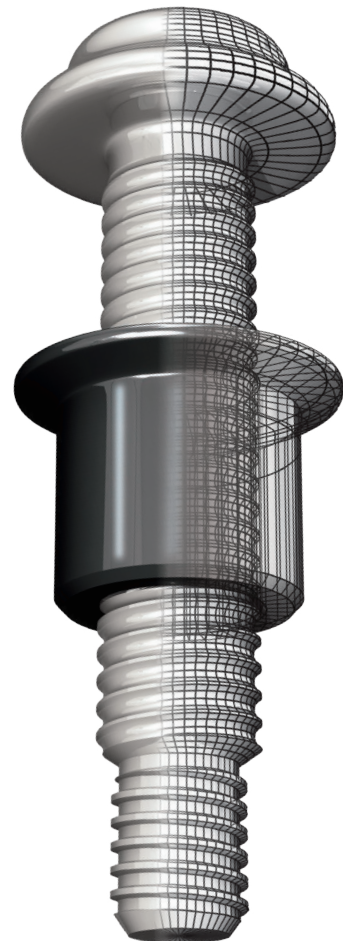

Unmatched Speed of Installation

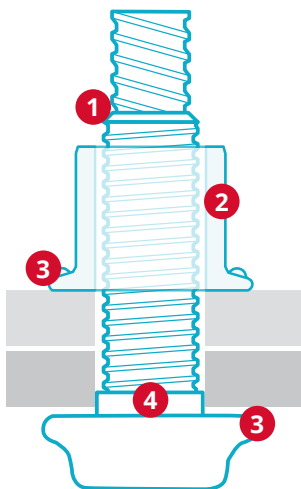

- 1 High fatigue thread form extends the life of your structure.
- 2 Corrosion resistant coatings can be painted.
- 3 Flanged collar and head spread load to ensure structural integrity.
- 4 Excellent gap pull-out and high retained clamp.

Quick, Easy Visual Inspection

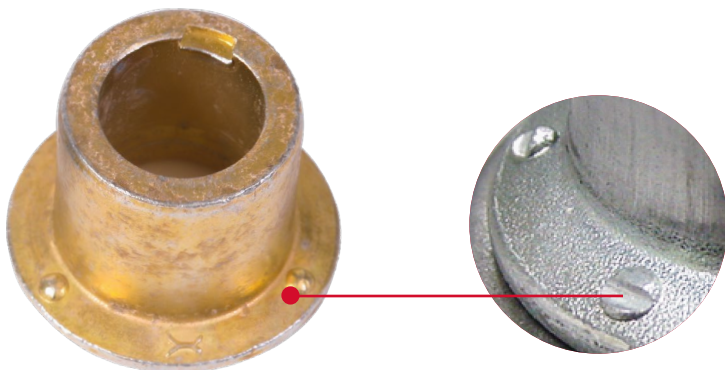

"Dots" on the Huck-Spin 2 collar indicates a full swage when at least one is crossed by the swage anvil.

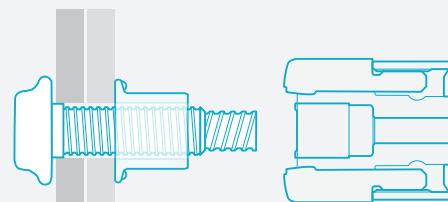

- 1 The bolt is inserted into the hole, and the collar is started onto the bolt thread by hand.

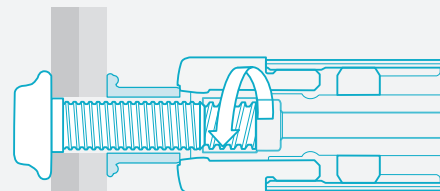

- 2 The installation tool spins onto the bolt pull-threads and removes all gap.

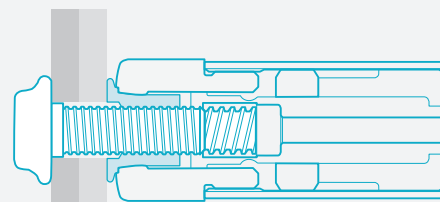

- 3 The swaging anvil is pushed over collar, locking it into threads and clamping the joint.

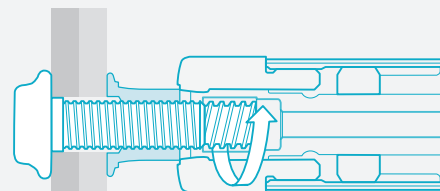

- 4 The tool ejects the swaged collar and spins off the pull threads.

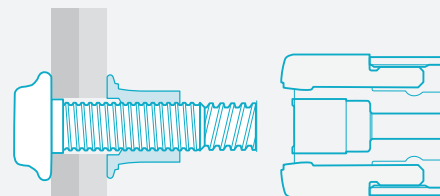

- 5 The tool separates to complete the fastener installation.

* Based on a typical installation of a 5/8" Grade 8 fastener

Inch Data and Dimensions

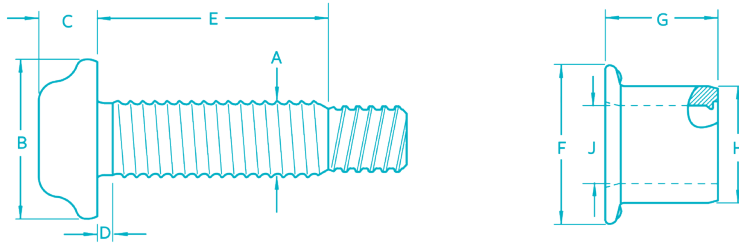

Fastener Dimensions

DIA.	A	B	C
1/2"	.500 max	1.010 - 1.080	.360 - .400
5/8"	.625 max	1.270 - 1.330	.448 - .499
3/4"	.750 max	1.520 - 1.600	.550 - .600

Collar Dimensions

DIA.	F	G	H	J
1/2"	1.010 - 1.080	.728 - .748	.762 - .772	.506 - .518
5/8"	1.270 - 1.330	.912 - .932	.953 - .963	.632 - .644
3/4"	1.520 - 1.600	1.095 - 1.115	1.145 - 1.155	.762 - .774

Grip Tables Inch

GRIP	1/2"			5/8"		3/4"	
	GRIP RANGE	D	E	D	E	D	E
4	.125 - .500	.180	1.309	.150	1.520	.180	1.712
6	.188 - .630	.180	1.434	.150	1.650	.180	-
8	.250 - .750	.180	1.559	.150	1.770	.180	1.962
10	.375 - .880	.180	1.684	.150	1.890	.180	-
12	.500 - 1.000	.180	1.809	.150	2.020	.180	2.212
16	.750 - 1.250	.180	2.059	.150	2.270	.180	2.462
20	1.000 - 1.500	.180	2.309	.150	2.520	.180	2.712
24	1.250 - 1.750	.180	2.559	.150	2.770	.180	2.962
28	1.500 - 2.000	.180	2.809	.150	3.020	.180	3.212
32	1.750 - 2.250	.180	3.059	.150	3.270	.180	3.462
36	2.000 - 2.500	.180	3.309	.150	3.520	.180	3.712
40	2.250 - 2.750	.180	3.559	.150	3.770	.380	3.962
44	2.500 - 3.000	.180	3.809	.380	4.020	.380	4.212
48	2.750 - 3.250	.380	4.059	.380	4.270	.380	4.462
52	3.000 - 3.500	-	-	.380	4.520	.380	4.712
56	3.250 - 3.750	-	-	.380	4.770	.380	4.962
60	3.500 - 4.000	-	-	.380	5.020	.380	5.212
72	4.250 - 4.750	-	-	.380	5.770	-	-

Installed Fastener Values

DIA.	MIN CLAMP (LBF)	MIN TENSILE (LBF)	MIN SHEAR (LBF)
1/2"	15,800	21,300	16,400
5/8"	26,000	36,600	26,000
3/4"	37,200	50,100	38,000

Hole Data

DIA.	MAX HOLE
1/2"	9/16"
5/8"	11/16"
3/4"	13/16"

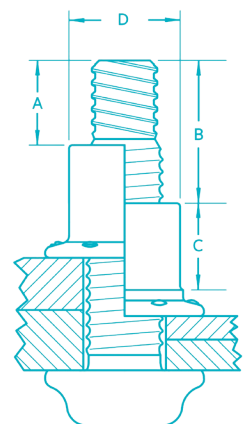

Inspection Data

DIA.	A MIN	B MAX	C MIN	D MAX
1/2"	.540	1.140	.568	.726
5/8"	.675	1.300	.710	.908
3/4"	.810	1.460	.852	1.090

Should "A" or "B" dimensions exceed the given values, the fastener is out-of-grip.
A "C" dimension less than the given value indicates an incomplete swage. A "D" dimension greater than the given values indicates an incorrect or worn anvil on the installation tool.



Metric Data and Dimensions

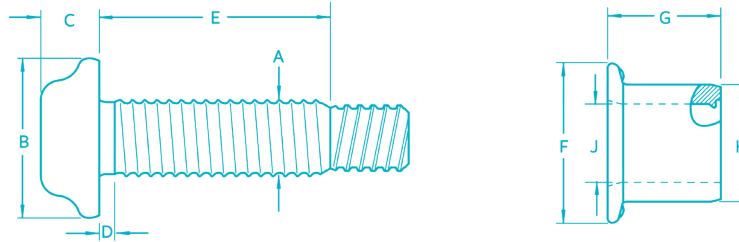

Fastener Dimensions

DIA.	A	B	C
14mm	14.0 max	30.0 max	11.5 max
20mm	20.0 max	42.4 max	16.1 max

Collar Dimensions

DIA.	F	G	H	J
14mm	28.2 - 29.6	20.5 - 21.0	21.1 - 21.5	14.0 - 14.4
20mm	40.2 - 42.2	29.0 - 29.6	30.2 - 30.6	20.1 - 20.5

Grip Tables Metric

GRIP	14MM			20MM		
	GRIP RANGE	D	E	GRIP RANGE	D	E
10	4 - 19	3.8	42.4	4 - 16	4.3	48
15	9 - 24	3.8	47.4	9 - 21	4.3	53
20	14 - 29	3.8	52.4	14 - 26	4.3	58
25	19 - 34	3.8	57.4	19 - 31	4.3	63
30	24 - 39	3.8	62.4	24 - 36	4.3	68
35	29 - 44	3.8	67.4	29 - 41	4.3	73
40	34 - 49	3.8	72.4	34 - 46	4.3	78
45	39 - 54	3.8	77.4	39 - 51	4.3	83
50	44 - 59	3.8	82.4	44 - 56	4.3	88
55	49 - 64	3.8	87.4	49 - 61	4.3	93
60	54 - 69	3.8	92.4	54 - 66	4.3	98
65	59 - 74	9.5	97.4	59 - 71	9.5	103
70	64 - 79	9.5	102.4	64 - 76	9.5	108
75	69 - 84	9.5	107.4	69 - 81	9.5	113
80	-	-	-	74 - 86	9.5	118
110	101 - 119	9.5	142.4	-	-	-

Installed Fastener Values

DIA.	MIN CLAMP (LBF)	MIN TENSILE (LBF)	MIN SHEAR (LBF)
14mm	84kN	120kN	94kN
20mm	181kN	255kN	182kN

Hole Data

DIA.	MAX HOLE
14mm	15.5mm
20mm	22mm

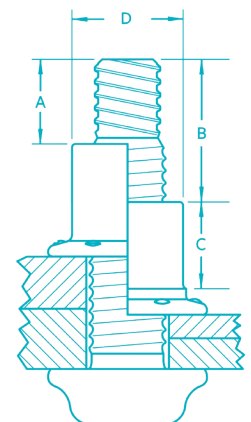

Inspection Data

DIA.	A MIN	B MAX	C MIN	D MAX	Should "A" or "B" dimensions exceed the given values, the fastener is out-of-grip. A "C" dimension less than the given value indicates an incomplete swage. A "D" dimension greater than the given values indicates an incorrect or worn anvil on the installation tool.
14mm	15.3	33.1*	15.8	20.2	
20mm	21.9	37.9	22.6	28.8	

* -110 grip max is 37mm



Ordering Information

Follow the form below to construct a part number for ordering Huck-Spin 2 pins and their respective collars. Refer to the Grip Tables (pages 4-5) for grip numbers.

Pins: (TYPE)-(DIAMETER)-(GRIP NUMBER) (FINISH)

Example: HS2P-DT16-10 is a Huck Spin 2, 1/2" Diameter, Grip 10, oil finish

Collars: TYPE-(DIAMETER)-(FINISH)

Example: MBTC-R14BL is a Metric Huck Spin 2 collar, 14mm diameter, zinc plate black chromate finish

Pins

TYPE	PREFIX
Inch	HS2P
Metric	MHS2P

DIAMETER	CODE
1/2"	DT16
5/8"	DT20
3/4"	DT24
14mm	DT14
20mm	DT20

GRIP
Refer to the Grip Tables on pages 4-5

FINISH	SUFFIX
Black Oiled	-
Geomet-1 coat	NP
Geomet-2 Coat	D1

Collars

DIAMETER	PART NUMBER
1/2"	BTC8-R16BL
5/8" (16mm)	MBTC-R16BL
3/4"	BTC8-R24BL
14mm	MBTC-R14BL
20mm	MBTC-R20BL



Installation Tooling

Tooling Selection (Inches)

SIZE	TOOL	NOSE	STYLE
1/2"	HS37	99-7362	Installation - Standard
	HS52	99-7356	Installation - Standard (HS37 Dia. Anvil)
		99-7358	Installation - Short
		99-7359	Installation - Long
		99-7363	Installation - Standard
		99-7363CC	Removal
		HSSFT-M12	99-7660
	3585PT	99-7520	Installation - Standard
		99-7520CC	Removal
	5/8"	HS52	99-7365
99-7366			Installation - Short
99-7367			Installation - Long
99-7368			Installation - Extra Long
HSSFT-M16		99-7662	Installation - Standard
		99-7662CC	Removal
		99-7662-5	Installation - Standard
3585PT		99-7521	Installation - Standard
		99-7521CC	Removal
3/4"		HS52	99-7364
	99-7364CC		Removal
	3585PT	99-7523	Installation - Standard
		99-7523CC	Removal

Tooling Selection (Metric)

SIZE	TOOL	NOSE	STYLE
14mm	HS52	99-7465	Installation - Standard
	HSSFT-M16	99-7762	Installation - Standard
		99-7762-4	Installation - Long
	3585PT	99-7531	Installation - Standard
		99-7531CC	Removal
16mm	HSSFT-M16	99-7662	Installation - Standard
		99-7662CC	Removal
		99-7662-5	Installation - Long
	3585PT	99-7521	Installation - Standard
		99-7521CC	Removal
		HS52	call for info
20mm	3585PT	99-7468 - 20MM HS52	Installation - Standard
		99-7563	Removal
		99-7563CC	

Model 3585PT





**HOWMET
AEROSPACE**

Howmet Fastening Systems

Industrial Division Brands



Huck, Marson, Recoil, Keysert, Camloc, Simmonds and Snep are trademarks of Howmet Aerospace Inc. and/or its subsidiaries.

The information contained in this publication is only for general guidance, and is not intended to create any warranty, express, implied, or statutory; all warranties are contained only in Howmet Fastening Systems' written quotations, acknowledgments, and/or purchase orders. It is recommended that the user secure specific, up-to-date data and information regarding each application and/or use of such products.

© 2020 Howmet Aerospace Inc. All rights reserved. HFS5672 0420
Huck-Spin is a trademark of Howmet Aerospace Inc. and/or its subsidiaries.





Distributed by

Applifast.

We are committed.



Contact Applifast

251 Cree Crescent

Winnipeg, MB

Canada R3J 3X4

Tel: 204 837 8361 • 1 800 563 1293

Fax: 204 837 3520 • 1 800 974 1494

info@applifast.com



applifast.com