



**HOWMET  
AEROSPACE**

# BobTail<sup>®</sup>

The Next Generation  
HuckBolt<sup>®</sup>



# Huck® BobTail®

## Huck's Next-Generation, Pintail-Less HuckBolt

Representing the most advanced fastening technology to date, the BobTail® delivers the highest level of performance and reliability.

Engineered to meet the challenges of a wide range of assembly applications, BobTail offers safe, quiet, swaged-on installation technology in a unique, pintail-less design. Available in an assortment of sizes, in both Grade 5 and Grade 8. BobTail offers 5 times the fatigue strength of conventional nuts and bolts and unmatched installation speed – often under 2 seconds per fastener.

Its unique no-break-off pintail offers the highest corrosion-resistance in its class, while advanced, low-swage technology enables installation with lightweight, ergonomic tools. When you factor in the cost of fasteners with installation and inspection labor, BobTail often provides an overall lower installed cost.

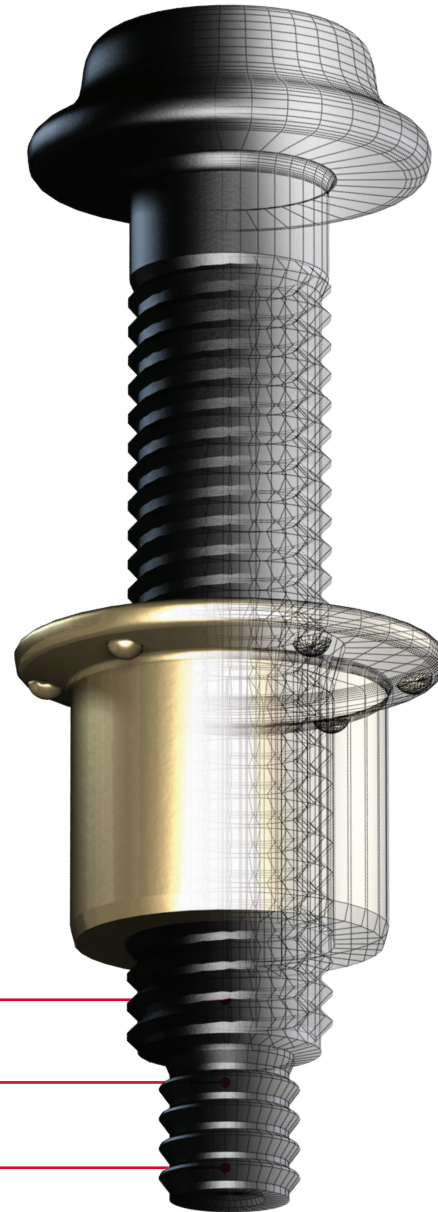

**Available Sizes** 1/2", 5/8", 3/4", 7/8", 1"  
12mm, 14mm, 16mm, 20mm

**Materials** Steel, Aluminum, Stainless Steel

**Headstyles** Round, Truss, 90° Flush, Flanged, 98T, Trazier

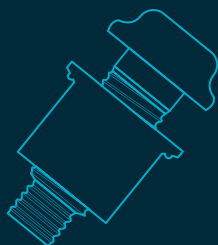

- ✓ No pintail
- ✓ Maintenance Free
- ✓ Low overall installed cost
- ✓ Superior strength (fatigue)
- ✓ Vibration resistance
- ✓ Quiet installation
- ✓ No repetitive stress injuries
- ✓ No special training or skills required for installation personnel
- ✓ Quick visual inspection is all that's needed for a quality-assured joint

## Unmatched Speed of Installation

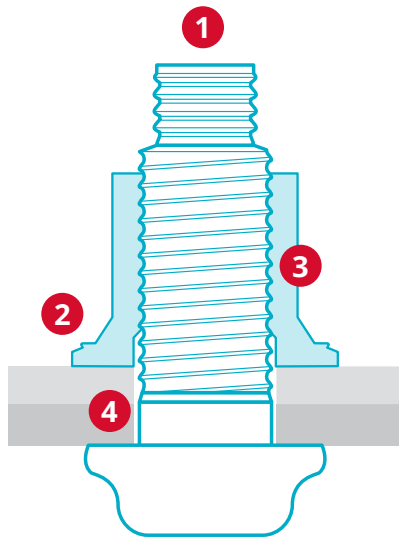

- 1 Pintail-less design means reduced noise, no waste, and improved corrosion resistance.
- 2 Visual evidence of successful installation provided by installation indicator.
- 3 Collar material swaged into the lockgrooves forms a permanent, vibration-resistant connection.
- 4 Low-swage technology allows for faster, lighter, ergonomic tooling with parts that last longer.

**For Oversized Holes:** To optimize clamp, hardened washers such as ASTM F436, DIN 6916 or EN 14399-6 are recommended for use with oversize holes and slots, along with good bolting practice.

## Quick, Easy Visual Inspection

Combining an advanced fastener design with the latest in easy-to-use, ergonomic installation tooling, the BobTail system delivers a strong connection and sets a new standard for ease of installation.



“Dots” on the BobTail collar indicates a full swage when at least one is crossed by the swage anvil.

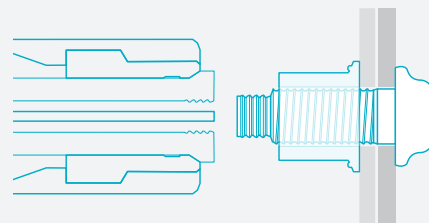

Insert pin into the prepared hole, spin the collar onto the pin.

1

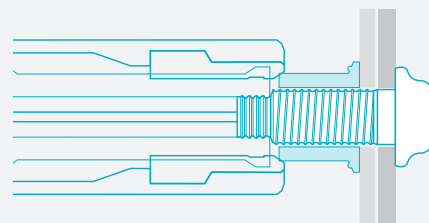

The installation tool is applied to annular pull grooves. When the tool is activated, a puller in the nose assembly draws the pin into the tool, causing the swaging anvil to press on the collar, drawing up any sheet gap.

2

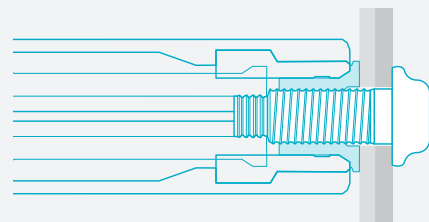

At a predetermined force, the anvil begins to swage the collar into the pin's lockgrooves. Continued swaging elongates the collar and pin, developing precise clamp.

3

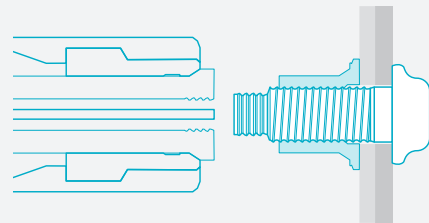

When swaging of the collar into the pin lockgrooves is complete, the tool ejects the fastener and releases the puller to complete the sequence.

4

# BobTail System

Not Just Manufactured. Huck-Engineered

Unlike conventional nuts and bolts, which have gaps on the thread flanks even when tightened, the BobTail system is designed for full metal-to-metal contact around the bolt thread by the collar. An installed BobTail has no gaps and delivers a more secure connection, providing reliability even in the most severe environments.



Increased Life,  
Decreased Maintenance,  
Virtually Vibration Proof

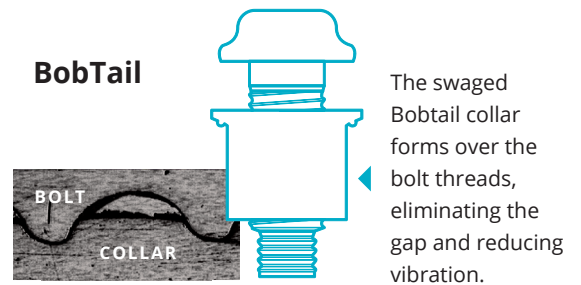
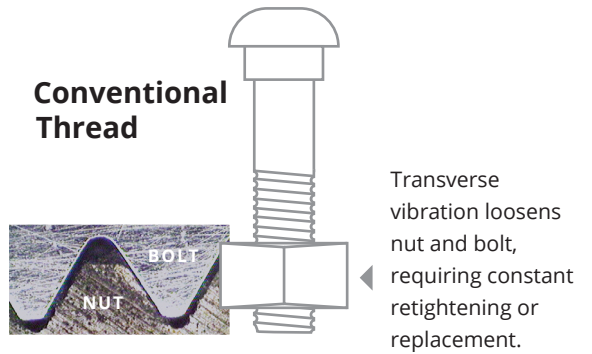
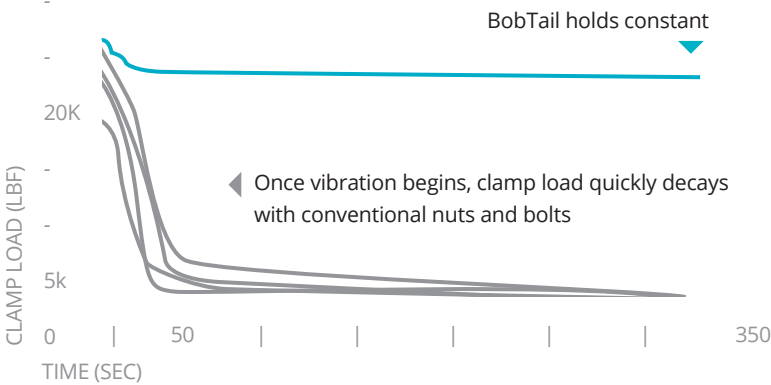

# Data and Dimensions

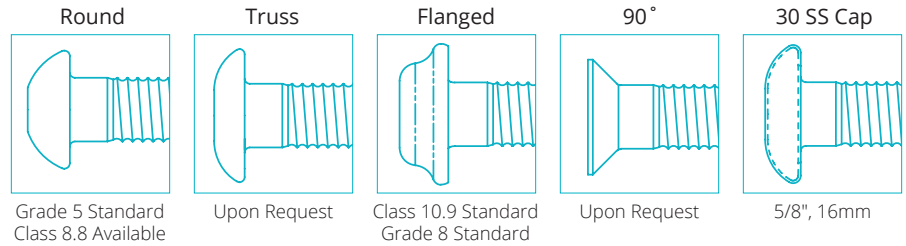
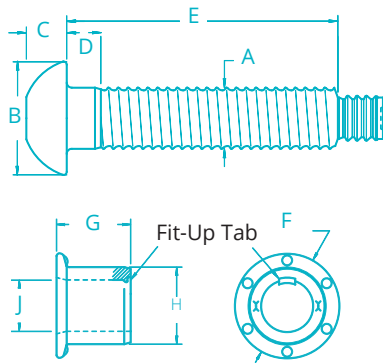

## Fastener Dimensions

DIA.	A MAX	ROUND HEAD		FLANGED HEAD		STAINLESS STEEL CAP		TRUSS / 90° / 30	
		B	C	B	C	B	C	B	C
1/2"	.500	.953 - .861	.297 - .335	—	—	—	—	Upon Request	—
5/8"	.625	1.086 - 1.196	.367 - .432	1.270 - 1.330	.448 - .499	1.270 - 1.330	.300 - .340	Upon Request	—
3/4"	.750	1.326 - 1.440	.455 - .530	1.520 - 1.600	.550 - .600	—	—	—	—
7/8"	.875	1.540 - 1.665	.525 - .585	—	—	—	—	—	—
1"	1.000	1.750 - 2.000	.590 - .650	—	—	—	—	—	—
12mm	12.0	—	—	24.1 - 25.4	8.9 - 9.6	—	—	—	—
14mm	14.0	—	—	30.0 max	11.5 max	—	—	—	—
16mm	16.0	—	—	32.3 - 33.8	11.4 - 12.2	—	—	—	—
20mm	20.0	—	—	40.3 - 42.4	15.0 - 16.0	—	—	—	—

## Standard Head Style and Strength Levels

DIA.	ROUND	FLANGED
1/2"	Grade 5	Grade 8
5/8"	Grade 5	Grade 8
3/4"	Grade 5	Grade 8
7/8"	Grade 5	Grade 8 Upon Request
1"	Grade 8	Grade 5
12mm	Class 8.8 Upon Request	Class 10.9
14mm	Class 8.8	Class 10.9, Class 8.8
16mm	Class 8.8 Upon Request	Class 10.9
20mm	Class 8.8 Upon Request	Class 10.9



BobTail HuckBolts also available in thread-head configuration for limited clearance applications.

# Data and Dimensions

## Collar Dimensions (inch)

DIA.	F	G	H		J
			GRADE 5	GRADE 8	
1/2"	1.010 - 1.080	0.728 - 0.748	0.749 - 0.759	0.762 - 0.772	0.506 - 0.518
5/8"	1.270 - 1.330	0.912 - 0.932	0.935 - 0.945	0.953 - 0.963	0.633 - 0.645
3/4"	1.520 - 1.600	1.095 - 1.115	1.132 - 1.142	1.145 - 1.155	0.760 - 0.774
7/8"	1.775 - 1.865	1.280 - 1.300	1.310 - 1.325	—	0.885 - 0.900
1"	1.930 - 2.010	1.460 - 1.490	1.500 - 1.515	1.525 - 1.540	1.010 - 1.030

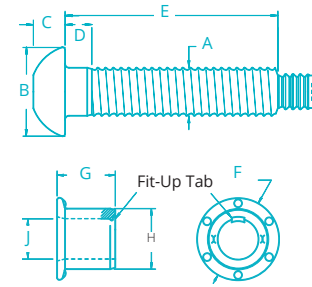

## Grip Tables (inch)

GRIP	GRIP RANGE	1/2"		5/8"		3/4"		7/8"		1"	
		D	E	D	E	D	E	D	E	D	E
4	.25-.62	0.150	1.440	0.150	1.601	0.160	1.850	0.250	2.056	0.250	2.260
8	.50-.87	0.150	1.690	0.150	1.851	0.160	2.100	0.250	2.306	0.250	2.510
12	.75-1.12	0.150	1.940	0.150	2.101	0.160	2.350	0.250	2.556	0.250	2.760
16	1.00-1.37	0.150	2.190	0.150	2.351	0.160	2.600	0.250	2.806	0.250	3.010
20	1.25-1.62	0.150	2.440	0.150	2.601	0.160	2.850	0.250	3.056	0.250	3.260
24	1.50-1.87	0.150	2.690	0.150	2.851	0.160	3.100	0.250	3.306	0.250	3.510
28	1.75-2.12	0.150	2.940	0.150	3.101	0.160	3.350	0.250	3.556	0.250	3.760
32	2.00-2.37	0.150	3.190	0.150	3.351	0.160	3.600	0.500	3.806	0.500	4.010
36	2.25-2.62	0.150	3.440	0.150	3.601	0.160	3.850	0.500	4.056	0.500	4.260
40	2.50-2.87	0.150	3.690	0.150	3.851	0.375	4.100	0.500	4.306	0.500	4.510
44	2.75-3.12	0.150	3.940	0.375	4.101	0.375	4.350	0.500	4.556	0.500	4.760
48	3.00-3.37	0.375	4.190	0.375	4.351	0.375	4.600	0.500	4.806	0.500	5.010
52	3.25-3.62	0.375	4.440	—	—	0.375	4.850	0.500	5.056	0.500	5.260
56	3.50-3.87	0.375	4.690	—	—	0.375	5.100	0.500	5.306	0.500	5.510
60	3.75-4.12	0.375	4.940	—	—	0.375	5.350	0.500	5.556	0.500	5.760
64	4.00-4.37	—	—	—	—	0.375	5.600	0.500	5.806	0.500	6.010
68	4.25-4.62	—	—	—	—	0.375	5.850	0.500	6.056	0.500	6.260
72	4.50-4.87	—	—	—	—	0.375	6.100	0.500	6.306	0.500	6.510

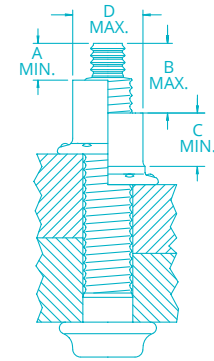

Should "A" or "B" dimensions exceed the given values, the fastener is out-of-grip. A "C" dimension less than the given value indicates an incomplete swage. A "D" dimension greater than the given values indicates an incorrect or worn anvil on the installation tool.

## Installed Fastener Values - lbf (KN)

DIA.	CLAMP		TENSILE		SHEAR	
	GRADE 5	GRADE 8	GRADE 5	GRADE 8	GRADE 5	GRADE 8
1/2"	12,050 (53.6)	15,800 (70.3)	17,050 (75.8)	21,300 (94.7)	14,000 (62.3)	16,400 (72.9)
5/8"	19,200 (85.4)	26,000 (115.6)	27,100 (120.5)	36,600 (162.8)	22,500 (100.1)	26,000 (115.6)
3/4"	28,400 (126.3)	37,200 (165.5)	40,100 (178.4)	50,100 (222.8)	32,400 (144.1)	38,000 (169.0)
7/8"	39,250 (174.6)	—	55,450 (246.6)	—	43,400 (193.0)	—
1"	51,500 (229.1)	64,000 (284.7)	72,700 (323.4)	90,900 (404.3)	56,500 (251.3)	68,000 (302.5)

## Hole Data (inch)

DIA.	MAX HOLE
1/2"	9/16"
5/8"	11/16"
3/4"	13/16"
7/8"	15/16"
1"	1-1/8"

## Inspection Data (inch)

DIA.	A MIN	B MAX	C MIN	D MAX
1/2"	.428"	.933"	.568"	.726"
5/8"	.428"	.959"	.710"	.908"
3/4"	.535"	1.098"	.852"	1.090"
7/8"	.600"	1.192"	.990"	1.261"
1"	.685"	1.308"	1.150"	1.452"

### Collar Dimensions (metric)

DIA.	F	G	H	J
12mm (10.9)	24.1 - 25.4	17.3 - 17.7	18.3 - 18.5	12.1 - 12.3
14mm (8.8)	28.2 - 29.6	20.5 - 21.0	20.9 - 21.1	14.0 - 14.3
14mm (10.9)	28.2 - 29.6	20.5 - 21.0	21.1 - 21.5	14.0 - 14.4
16mm (10.9)	32.3 - 33.8	23.1 - 23.7	24.1 - 24.5	16.0 - 16.4
20mm (10.9)	40.3 - 42.1	29.0 - 29.6	30.2 - 30.6	20.1 - 20.5

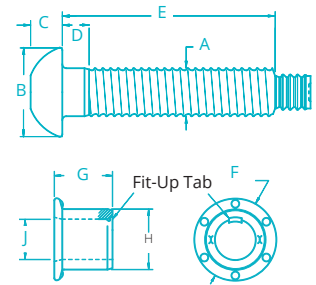

### Grip Tables (metric)

GRIP	GRIP RANGE	12MM		14MM		16MM		20MM	
		D	E	D	E	D	E	D	E
10	5-15	3.8	34.2	3.8	37.1	3.8	40.1	3.8	45.9
15	10-20	3.8	39.2	3.8	42.1	3.8	45.1	3.8	50.9
20	15-25	3.8	44.2	3.8	47.1	3.8	50.1	3.8	55.1
25	20-30	3.8	49.2	3.8	52.1	3.8	55.1	3.8	60.9
30	25-35	3.8	54.2	3.8	57.1	3.8	60.1	3.8	65.9
35	30-40	3.8	59.2	3.8	62.1	3.8	65.1	3.8	70.9
40	35-45	3.8	64.2	3.8	67.1	3.8	70.1	3.8	75.9
45	40-50	3.8	69.2	3.8	72.1	3.8	75.1	3.8	80.9
50	45-55	3.8	74.2	3.8	77.1	9.5	80.1	3.8	85.9
55	50-60	3.8	79.2	3.8	82.1	9.5	85.1	3.8	90.9
60	55-65	3.8	84.2	3.8	87.1	9.5	90.1	3.8	95.9
65	60-70	3.8	89.2	3.8	92.1	9.5	95.1	9.5	100.9
70	65-75	3.8	94.2	3.8	97.1	9.5	100.1	9.5	105.9
75	70-80	3.8	99.2	9.5	102.1	9.5	105.1	9.5	110.9
80	75-85	9.5	104.2	9.5	107.1	9.5	110.1	9.5	115.9
85	80-90	—	—	—	—	9.5	115.1	9.5	120.9
90	85-95	—	—	—	—	9.5	120.1	9.5	125.9
95	90-100	—	—	—	—	9.5	125.1	9.5	130.9
100	95-105	—	—	—	—	9.5	130.1	9.5	135.9
105	100-110	—	—	—	—	9.5	135.1	9.5	140.9
110	105-115	—	—	—	—	9.5	140.1	9.5	145.9
115	110-120	—	—	—	—	9.5	145.1	9.5	150.9
120	115-125	—	—	—	—	9.5	150.1	9.5	155.9
125	120-130	—	—	—	—	—	—	9.5	160.9
130	125-135	—	—	—	—	—	—	9.5	165.9
135	130-140	—	—	—	—	—	—	9.5	170.9

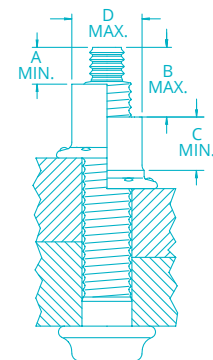

Should "A" or "B" dimensions exceed the given values, the fastener is out-of-grip. A "C" dimension less than the given value indicates an incomplete swage. A "D" dimension greater than the given values indicates an incorrect or worn anvil on the installation tool.

### Installed Fastener Values - lbf (KN)

DIA.	CLAMP	TENSILE	SHEAR
12mm (10.9)	14,600 (64.9)	19,700 (87.6)	14,700 (65.4)
14mm (8.8)	15,000 (66.7)	21,500 (95.6)	18,500 (82.3)
14mm (10.9)	19,500 (86.7)	27,000 (120.1)	21,100 (93.8)
16mm (10.9)	26,000 (115.6)	36,600 (163.0)	26,000 (115.6)
20mm (10.9)	40,700 (181.0)	57,300 (254.9)	41,000 (182.4)

### Inspection Data (metric)

DIA.	A MIN	B MAX	C MIN	D MAX
12mm	10.9mm	24.0mm	14.1mm	17.3mm
14mm	10.9mm	24.4mm	15.8mm	20.2mm
16mm	10.9mm	24.8mm	18.0mm	23.1mm
20mm	13.9mm	28.5mm	22.6mm	28.8mm

### Hole Data (metric)

DIAMETER	MAX HOLE
12mm	13.5mm (17/32")
14mm	15.5mm (39/64")
16mm	17.5mm (11/16")
20mm	22mm (7/8")



# Installation Tooling

## Lightweight, Technologically Advanced Tooling

Newly designed BobTail tooling makes the installation process quicker and easier by reducing the force required to install each fastener. More compact and lighter weight than previous Huck lockbolt production tooling, BobTail installation tools also offer greater operator flexibility as well as extended reach into difficult areas.

For tight, space-constrained applications, SWAGEFORWARD® BobTail tools allow the operator to position their hand at a safe distance from the working structure during installation.

## Cost-Efficient Operation

Smooth-operating BobTail installation tooling directly contributes to longer tool and component life, while allowing extended tool maintenance cycles. As a result, costs for parts and overall support are reduced, while system uptime is increased.

## Cost-Efficient Operation

The BobTail fastener is installed without a pin-break, contributing to the dramatic reduction of noise on the shop floor, and subsequently, improved worker hearing safety. Instances of foreign object damage (FOD) and loose pintail injuries are eliminated. Because BobTail tooling features a smooth, shock-free installation sequence, repetitive stress injuries are eliminated, and overall safety is increased.



Model SF20  
SWAGEFORWARD®



Model SF46-250-02



### Tooling Selection (inch)

DIA.	TOOL*	INSTALLATION	CUTTER
1/2"	SF20	99-7882	99-7882CX
5/8"	SF20	99-7881	99-7881CX
3/4"	SF32	99-7894	99-7893CX
7/8"	SF46-250-02	99-7863	99-7863CX
1"	SF46-250-02	99-7867	99-7867CX

### Tooling Weight and Dimensions (inch)

MODEL	WEIGHT	LENGTH	HEIGHT	WIDTH
SF20	12.7 lbs	5.52	8.48	2.88
SF32	12.5 lbs	5.58	9.03	3.40
SF46-250-02	22.3 lbs	7.33	9.455	4.00

### Nose Assembly Clearance Dimensions

INSTALL	FIG	A	B	C
99-7830	A	5.73	2.21	1.31
99-7831	A	6.29	4.28	1.75
99-7832	A	7.59	N/A	2.19
99-7834	A	5.73	2.77	1.61
99-7835	A	5.73	2.43	1.43
99-7836	A	7.58	N/A	2.19
99-7863	C	1.48	2.44	N/A
99-7867	C	1.70	2.75	N/A
99-7880	C	1.01	1.31	N/A
99-7881	C	1.06	1.75	N/A
99-7882	C	1.01	1.43	N/A
99-7884	C	1.01	1.61	N/A
99-7893	C	1.57	2.19	N/A
99-7894	C	1.21	2.19	N/A

CUTTER	FIG	A	B	C
99-7830CX	A	5.72	3.20	1.44
99-7831CX	A	6.23	4.12	1.75
99-7832CX	A	7.89	4.24	2.18
99-7834CX	A	5.72	3.61	1.75
99-7835CX	A	5.72	3.62	1.56
99-7863CX	C	1.69	2.75	N/A
99-7867CX	C	1.69	2.75	N/A
99-7880CX	C	2.32	1.31	N/A
99-7881CX	C	2.51	1.75	N/A
99-7882CX	C	2.41	1.43	N/A
99-7884CX	C	2.51	1.69	N/A
99-7894CX	C	1.69	2.19	N/A

### Tooling Selection (metric)

DIA.	TOOL*	INSTALLATION	CUTTER
12mm	SF20	99-7880	99-7880CX
14mm	SF20	99-7884	99-7884CX
16mm	SF20	99-7881	99-7881CX
20mm	SF32	99-7893	99-7893CX

### Collar Cutter Feature

While BobTail fasteners install permanently, BobTail installation tooling features a collar cutter nosepiece that makes fastener removal easier than ever.

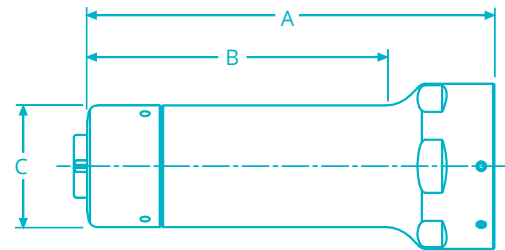

Fig. A

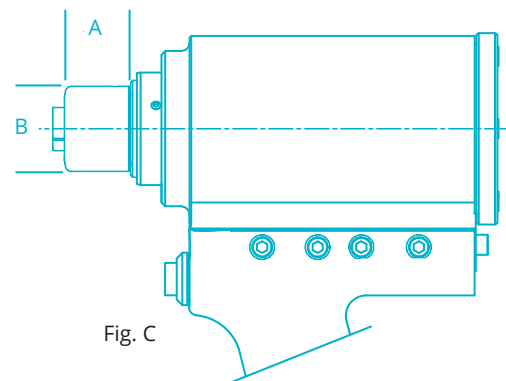

Fig. C

Other BobTail tooling options are available.



# Power Units

The standard BobTail installation system includes a Powerig® hydraulic power unit, hydraulic hoses, fittings, and a BobTail installation tool.



Powerig  
Model 918



Powerig  
Model 940

## Huck Powerig® Hydraulic Units

MODEL 918	MODEL 940	MODEL 969 (NOT SHOWN)
High-production applications	Portable; production and repair	Portable; Repair
Operates up to 2 tools; 2 gpm flow rate	70 in 3/min flow rate	6 cubic in./min.
Electrically powered; 220, 440, or 550 volts, 3 phase	Electrically powered; 115 or 220 volts, single phase	6.2 BAR/90 psi Air
Weights 708 lbs, operational	Weights 75 lbs	Weights 18.4 lbs
44"L x 25"W x 30"H	12.5"L x 10.5"W x 18"H	9.5"L x 5"W x 10.4"H

# Ordering Information

Follow the form below to construct a part number for ordering BobTail pins and their respective collars.  
Refer to the Grip Tables (pages 6-7) for grip numbers.

**Pins:** BT (HEAD STYLE) - (MATERIAL) (DIAMETER) - (GRIP NUMBER) (FINISH)

**Example:** BTR-BR20-8 is a BobTail Pin, Round Head, Grade 5 Carbon Steel, 5/8" Diameter, Grip 8, Oil Finish

**Collars:** BT (TYPE) - (MATERIAL) (DIAMETER) (FINISH)

**Example:** BTC5-R20UA is a BobTail Collar, Grade 5 Carbon Steel, 5/8" Diameter, Zinc Plated

## Inch Series

BOLT HEAD STYLE	PREFIX	BOLT MATERIAL	CODE
Grade 5			
Round	BTR	Medium Carbon Steel	BR
Truss	BT30		
90° Flush	BT90		
Grade 8			
Flanged	BT	Alloy Steel	DT

DIA.	CODE
1/2"	16
5/8"	20
3/4"	24
7/8"	28
1"	32

GRIP
Refer to Grip Tables on pages 6-7

FINISH	SUFFIX
Zinc Plate, Clear Chromate .0003"	G*
Zinc Plate, Clear Chromate .0004"	GA*
Geomet - 1 Coat	NP
Geomet - 2 Coat	D1
Oil Finish	no suffix

\*Only available for Grade 5

## Metric Series

BOLT HEAD STYLE	PREFIX	BOLT MATERIAL	CODE
Class 8.8			
Round	MBTR	Medium Carbon Steel	BR
Flanged	MBT		
Class 10.9			
Flanged	MBT	Alloy Steel	DT

DIA.	CODE
12mm	12
14mm	14
16mm	16
20mm	20

GRIP
Refer to Grip Tables on pages 6-7

FINISH	SUFFIX
Zinc Plate, Clear Chromate .0003"	G**
Zinc Plate, Clear Chromate .0004"	GA**
Geomet - 1 Coat	NP
Geomet - 2 Coat	D1
Oil Finish	no suffix

\*\*Only available for Class 8.8

## Collars

GRADE / CLASS	PREFIX	MATERIAL	CODE
Grade 5	BTC5-	Low Carbon Steel	R
Grade 8	BTC8-	Low Carbon Steel	R
Class 8.8	MBTC-	Low Carbon Steel	BR
Class 10.9	MBTC-	Low Carbon Steel	R

DIA.	CODE
1/2"	16
5/8"	20
3/4"	24
7/8"	28
1"	32
12mm	12
14mm	14
16mm	16
20mm	20

FINISH	SUFFIX
Zinc Plate	UA
Zinc Plate	BL
Zinc Plate	UA
Zinc Plate	BL



**HOWMET  
AEROSPACE**

# Howmet Fastening Systems

## Industrial Division Brands



Huck, Marson, Recoil, Keysert, Camloc, Simmonds and Snep are trademarks of Howmet Aerospace Inc. and/or its subsidiaries.

The information contained in this publication is only for general guidance, and is not intended to create any warranty, express, implied, or statutory; all warranties are contained only in Howmet Fastening Systems' written quotations, acknowledgments, and/or purchase orders. It is recommended that the user secure specific, up-to-date data and information regarding each application and/or use of such products.

© 2020 Howmet Aerospace Inc. All rights reserved. HFS5786 0220  
BobTail, Powerig, Swageforward and HuckBolt are trademarks of Howmet Aerospace Inc. and/or its subsidiaries.





Distributed by

# Applifast.

*We are committed.*



**Contact Applifast**

251 Cree Crescent

Winnipeg, MB

Canada R3J 3X4

Tel: 204 837 8361 • 1 800 563 1293

Fax: 204 837 3520 • 1 800 974 1494

info@applifast.com



[applifast.com](http://applifast.com)