



Crane Electronics Ltd
The force in torque management



Crane Electronics Product Portfolio



NEW!

Crane Electronics Ltd
The force in torque management



The NEW TorqueStar Range from Crane Electronics

The new TorqueStar Data Collector series from Crane Electronics is the latest innovation of the ground-breaking Torque measurement system.

Ranging from the **TorqueStar Lite**, the new basic Torque Data Collector & Indicator, up to the **TorqueStar Plus**, with new full-colour screen, and the **TorqueStar Pro**, the most complete stand alone TorqueStar ever made.





Contents

Torque Transducers

- Static Torque Transducers
- CheckStar Rotary Torque Transducers
- CheckStar Multi Rotary Torque Transducers

Torque Data Collectors

- TorqueStar Lite Torque Data Collector
- TorqueStar Plus Torque Data Collector
- TorqueStar Pro Torque Data Collector
- IQVu Torque Data Collector

Digital Torque Wrenches

- IQWrench 2 Opta Digital Torque Wrenches
- WrenchStar Multi Digital Torque Wrenches

Tool Torque Stations

- MTTs (Mobile Tool Torque Station)
- tJRS (threaded Joint Rate Simulator)

Torque Software

- OMS (Opta Management Software)

Torque Testers

- ReadStar TT
- CapStar TT

Lineside Controllers

- TCI (Tool Controller Interface)
- TCI Multi

Accessories

Service & Calibration

Industries

Crane Electronics Ltd
The force in torque management

Torque Transducers

Throughout the history of Crane Electronics, we have pioneered the creation and development of innovative torque transducers and our current range raises the standard for dynamic torque & angle measurement of all continuous drive and impulse tools. With proven performance in thousands of applications worldwide, you can rest assured that our transducers offer the ultimate in precision measurement.

Torque transducers from Crane Electronics, including the CheckStar and CheckStar Multi rotary torque transducers, measure and record torque on a rotating system. We also offer stationary transducers which are the quality choice for tool testing, including continuous drive, impulse and hand torque tools in the workshop and line-side production environment.

The CheckStar Multi rotary torque transducer is the latest generation of Crane Electronics' market-leading in-line rotary torque transducers.



Stationary Transducers

Workbench-mounted Static Torque Transducer

Crane's stationary torque transducers are the quality choice for the testing of all continuous drive, impulse and hand torque tools in the workshop and line-side production environments.

Stationary transducers are used off the production line in workshop or line-side test stations. Combined with joint kits that can represent the production joint condition, the stationary transducers form an effective offline test for verification of assembly tool performance.

Stationary Transducers are a vital part of the Crane UTA torque system, enabling automatic transducer recognition with Crane data collectors and readout devices. On-board intelligence means the UTA transducer is automatically recognised by the Crane readout device, eliminating set-up errors and enabling the logging of serial number against measurements for complete traceability.

An Industry Standard (IS) version is also available, where a user needs the features of the stationary transducer but already has a readout device from another manufacturer.



Key Features

- ✓ Suitable for measurement of all continuous drive and hand torque Tools
- ✓ Automatic transducer recognition with Crane data collector & readout devices (Auto ID)
- ✓ Combine with joint kits for workshop simulation of 'Hard' to 'Soft' joints
- ✓ Incorporate into custom built Mobile Tool Test Stations (MTTS)

Stationary Transducers Technical Specification

| | |
|-------------------------------|--|
| Transducer Type: | UTA: incorporate data chip enabling automatic transducer recognition operation with Crane data collector & readout devices IS: 'Industry Standard' version Bridge resistance: 350 Ohms Sensitivity: 2mV/V |
| Construction: | Steel housing Overload capacity: 125% rated torque Square drives to ANSI B107-4 -1982; BS4006 – 1992; DIN 3121 – 1987 |
| Connections: | UTA: 1m integral cable with strain relief; 25-pin 'D' port (male) for connection to CEL readouts IS: output connector to MIL –C 26482 / BS 9522 FOO 17; shell size 8 -4P |
| Zero stability: | < ± 0.1% of FSD/°C |
| Static accuracy: | ±0.25% FSD |
| Operating environment: | Temperature: 5-40°C (-10 to 60°C with reduced specification) Humidity: 10-75% non-condensing Ingress Protection rating: IP40 |
| Warranty: | 12 months parts and labour against faulty workmanship or materials |
| Calibration: | All Torque equipment should be re-calibrated every 12 months |

Weights and Dimensions

| Dimensions in mm | | | | | | |
|------------------|-----|-----|----|------|-------------------|-------------|
| Drive | A | B | C | D | E | Weight (Kg) |
| 1/4" | 54 | 100 | 25 | 76.5 | 16 | 1.62 |
| 3/8" | 54 | 100 | 25 | 86 | 24 | 1.93 |
| 1/2" | 54 | 100 | 25 | 95 | 30 | 2.10 |
| 3/4" | 50 | 100 | 25 | 112 | 44 | 2.11 |
| 1" | 59 | 100 | 25 | 124 | 53 | 2.63 |
| 1 1/2" | 762 | 140 | 25 | 130 | 1.5" Across Flats | 3.20 |

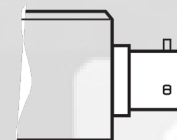
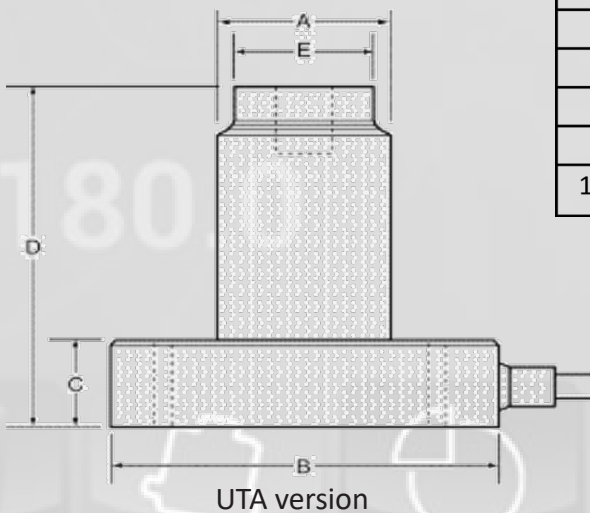

IS version connector detail

Crane Electronics Ltd
The force in torque management

CheckStar Transducers

In-line Rotary Torque Transducer

CheckStar torque transducers fit in-line between the assembly tool and the fastener, measuring the actual torque applied and the angular rotation of the fastener, under production conditions.

Whatever the vibration and shock loads experienced, CheckStar's patented contact system ensures a connection is always maintained between the readout and the strain gauges. Inferior systems suffer from "brush bounce" that leads to unreliable torque readings.

The low inertia design of the CheckStar ensures accurate and repeatable measurement of high speed transients, such as the point of shut-off on continuous drive tools and the pulsing of the impulse tools.

CheckStars forms an essential part of the Crane UTA torque system. On-board intelligence means the UTA CheckStar is automatically recognised by the Crane data collector or readout device, eliminating set-up errors and enabling the logging of the serial number against measurements for complete traceability.

An Industry Standard (IS) version is also available where a user needs the advanced features of the CheckStar but already has a readout device from another manufacturer. Both versions can be specified to include an angle encoder with 0.5° resolution.



Key Features

- ✓ Patented design ensures no "brush bounce" even when used with impulse tools
- ✓ Compatible with all continuous drive tools, impulse tools and torque wrenches
- ✓ Square and Hex drives available
- ✓ Industry Standard (IS) versions available (2mV/V; 1.475mV/V)
- ✓ Low inertia benefits accurate dynamic measurement
- ✓ Angle measurement option with no size increase (0.5° resolution)

CheckStar Technical Specification:

| | |
|------------------------------------|---|
| Plug & Play Transducer: | UTA system indicators read the following information from the UTA chip incorporated in the transducer device Torque range, angle encoder data, serial number, calibration due date |
| Transducer Types: | UTA: Incorporate data chip enabling automatic transducer recognition with compatible Crane indicators IS: 'Industry Standard' version; Bridge resistance: 350 Ohms |
| Calibration: | Issued with calibration certificate traceable to National and International Standards Standard Crane Calibration: 10 points; single direction (clockwise unless otherwise requested); 10% to 100% of nominal torque Bi-direction Crane Calibration: (optional) 10 points; each direction; from 10% to 100% of nominal torque UKAS Calibration: (optional) Calibration to BS 7882 Re-calibration is recommended every 12 months |
| Construction: | Aluminium housing Stainless steel shaft Overload capacity: 125% of rated Torque Square drives to ANSI B107-4 – 1982; BS4006 – 1992; DIN 3121 - 1987 Male square drive fitted with detent pin that may be removed if required Female square drive supplied with retaining pin that may be removed if required Female hex drive fitted with ball and spring retainer |
| Connections: | UTA version: 1m Integral curly cable with strain relief; 25-pin 'D' port (male) for connection to UTA Crane system readouts IS version: output connector to MIL-C 26482 / BS 9522 FOO 17 |
| Zero stability: | $< \pm 0.1\% \text{ FSD}/^{\circ}\text{C}$ |
| Static accuracy: | $\pm 0.25\% \text{ FSD}$ |
| Operating environment: | Temperature: $+5^{\circ}\text{C}$ to $+40^{\circ}\text{C}$ (-10°C to $+60^{\circ}\text{C}$) Humidity 10-75% non-condensing Ingress Protection rating: IP40. |
| Warranty: | 12 months parts and labour against faulty workmanship or materials |
| Patents applicable: | Slip-ring design protected by international patents |

Crane Electronics Ltd
The force in torque management

Dimensions and Weights - UTA CheckStar

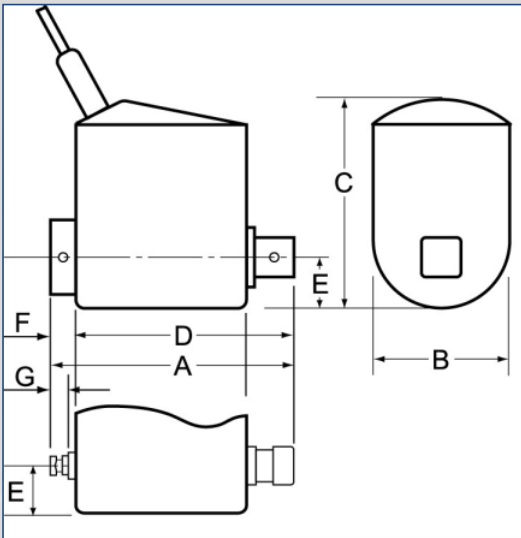

| Dimensions in mm | | | | | | | | |
|------------------|------|-----|------|------|------|----|------|-------------|
| Drive | A | B | C | D | E | F | G | Weight (Kg) |
| 1/4" Hex | 116 | 30 | 56 | 56 | 13 | 39 | 25.5 | 0.49 |
| 1/4" Sq. | 71.5 | 30 | 56 | 56 | 13 | 6 | - | 0.50 |
| 3/8" Sq. | 77 | 30 | 59.5 | 56 | 15 | 8 | - | 0.55 |
| 1/2" Sq. | 87 | 42 | 70 | 58 | 21 | 12 | - | 0.73 |
| 3/4" Sq. | 106 | 52 | 81 | 60 | 26 | 21 | - | 1.05 |
| 1" Sq. | 125 | 63 | 91.5 | 64.5 | 31.5 | 29 | - | 1.80 |
| 1 1/2" Sq. | 181 | 102 | 136 | 86.5 | 51 | 50 | - | 6.00 |

Dimensions and Weights - IS CheckStar

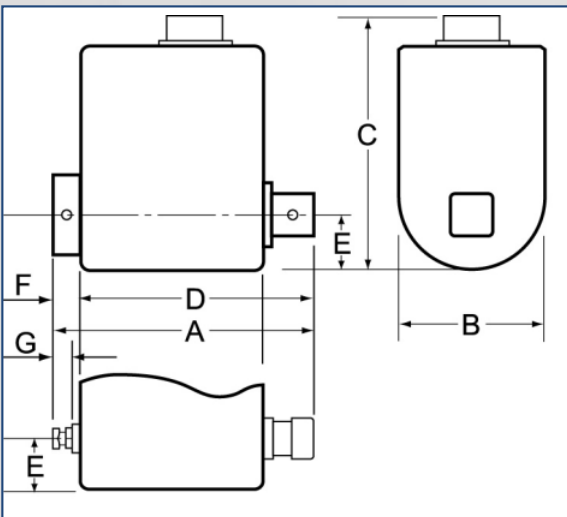

| Dimensions in mm | | | | | | | | |
|------------------|------|-----|------|------|------|----|------|-------------|
| Drive | A | B | C | D | E | F | G | Weight (Kg) |
| 1/4" Hex | 116 | 30 | 68 | 56 | 13 | 39 | 25.5 | 0.21 |
| 1/4" Sq. | 71.5 | 30 | 71.5 | 56 | 13 | 6 | - | 0.20 |
| 3/8" Sq. | 77 | 30 | 74 | 56 | 15 | 8 | - | 0.24 |
| 1/2" Sq. | 87 | 42 | 82.5 | 58 | 21 | 12 | - | 0.43 |
| 3/4" Sq. | 106 | 52 | 93.5 | 60 | 26 | 21 | - | 0.76 |
| 1" Sq. | 125 | 63 | 104 | 64.5 | 31.5 | 29 | - | 1.50 |
| 1 1/2" Sq. | 181 | 102 | 149 | 86.5 | 51 | 50 | - | 5.70 |

CheckStar Multi Transducers

In-line Rotary Torque Transducer

The CheckStar Multi is the latest generation of Crane Electronics' market leading CheckStar in-line rotary torque transducers. If angle is specified, the CheckStar Multi will include an angle encoder giving 0.125° resolution (720 PPR). It also incorporates a light ring, giving the user visual feedback of the status of a tightening when used with a Crane readout or data collector.

The CheckStar Multi fits in-line between the assembly tool and the fastener, measuring the actual torque applied and angular rotation of the fastener, under production conditions.

Whatever the vibration and shock loads experienced, CheckStar Multi's patented contact system ensures a connection is always maintained between the readout and the strain gauges. Inferior systems suffer from "brush bounce" that leads to unreliable torque readings.

The low inertia design of the CheckStar Multi ensures accurate and repeatable measurement of high speed transients, such as the point of shut-off on continuous drive tools and the pulsing of impulse Tools.

Using on-board intelligence, the CheckStar Multi is automatically recognised by a Crane data collector or readout device, eliminating set-up errors and enabling logging of serial number against measurements for complete traceability.



Key Features

- ✓ Low inertia benefits accurate and dynamic measurement
- ✓ Angle measurement option with no size increase (0.125° resolution)
- ✓ Patented design ensures no "brush bounce" even when used with impulse tools
- ✓ Low friction eliminates wear and supports high accuracy
- ✓ Suitable for use with all continuous drive tools, impulse tools and torque wrenches
- ✓ Easily viewed light ring showing status, when used with Crane data collectors and readouts



Crane Electronics Ltd
The force in torque management

CheckStar Multi Technical Specification:

| | |
|---|---|
| Special features: | Patented mechanism for reliable measurement of impulse tools. Integrated light ring giving visual indication of fastening status |
| Tool compatibility: | All torque tools, including impulse tools (not impact tools) Joint kit recommended for off-line measurement of continuous drive and impulse tools to represent joint conditions |
| Physical measurements: | Bi-directional torque (clockwise calibration unless otherwise specified) Optional bi-directional angle encoder (also enables RPM measurement on suitable indicator) |
| Automatic transducer: | A Crane readout can automatically read the following recognition information from the CheckStar Multi rotary torque transducer; torque range, angle encoder data, serial number, calibration due date |
| Calibration: | Issued w/calibration certificate traceable to National & International Standards. |
| Standard Crane Calibration: | 10 points; single direction (clockwise unless otherwise requested); 10% to 100% of nominal torque Re-calibration is recommended every 12 months |
| If required, the following calibrations are available: | |
| 5% Crane Calibration: | 11 points; single direction (clockwise unless otherwise requested). 5% to 100% of nominal torque |
| Bi-direction Crane: | 10 points; each direction; from 10% to 100% of nominal torque. |
| Class 1 Crane Calibration: | ± 0.5% of reading for the primary classification range |
| UKAS Calibration: | Calibration to BS 7882 |
| Construction: | Patented slip ring mechanism eliminating signal losses due to "brush bounce", enabling low running friction in either direction (<0.1% rated torque or 0.1Nm, whichever is greater); design is durability tested to >100 million revolutions with no measurable degradation of electrical performance Aluminium housing & stainless steel shaft Overload capacity: 125% rated Torque Square drives to ANSI B107-4 – 1982; BS4006 – 1992; DIN 3121 – 1987. Male square drive fitted with detent pin that may be removed if required. Female square drive supplied with retaining pin (may be removed if required). Female hex drive fitted with ball and spring retainer |
| Connections: | Compatible with BS 9522 - F0017 Cable mounting type 14-19S, Complies with MIL-C-26482. |
| Zero Stability: | < ± 0.1% FSD/°C |
| Static accuracy: | ± 0.25% FSD |
| Operating environment: | 5 to 40°C (-10 to 60°C with reduced specification) |
| Temperature: | Humidity: 10 to 75% non-condensing Ingress protection rating: IP40 |
| Warranty: | 2 year' parts and labour against faulty workmanship or materials. The second year of warranty is only valid if the unit has been re-calibrated at an authorised Crane Electronics Service Centre after the first year |



Crane Electronics Ltd
The force in torque management

Dimensions and Weights

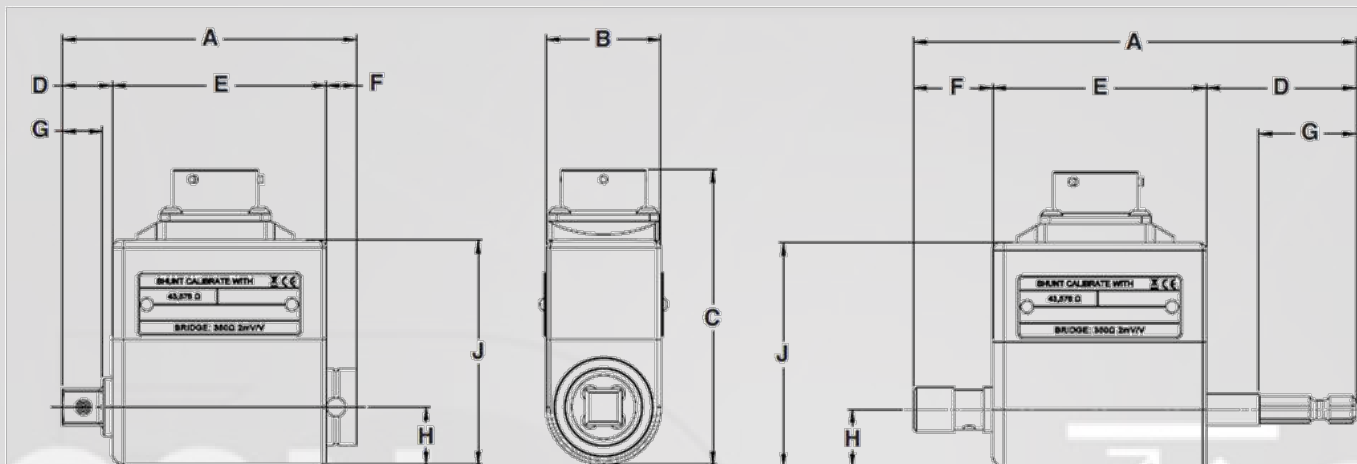

Dimensions in mm

| Drive | A | B | C | D | E | F | G | H | J | Weight (Grams) |
|------------|-------|-------|-------|------|------|------|------|------|-------|----------------|
| 1/4" Hex | 115.8 | 30.0 | 73.0 | 39.2 | 56.0 | 20.6 | 25.5 | 13.2 | 54.5 | 210 |
| 1/4" Sq. | 71.5 | 30.0 | 73.0 | 10.3 | 56.0 | 5.2 | 7.3 | 13.2 | 54.5 | 200 |
| 3/8" Sq. | 77.0 | 30.0 | 77.1 | 12.9 | 56.0 | 8.1 | 10.5 | 15.0 | 58.6 | 240 |
| 1/2" Sq. | 87.0 | 42.0 | 88.0 | 17.0 | 58.0 | 12.0 | 14.7 | 21.0 | 69.5 | 430 |
| 3/4" Sq. | 106.0 | 52.0 | 98.6 | 25.3 | 60.0 | 20.7 | 21.4 | 26.0 | 80.1 | 760 |
| 1" Sq. | 125.0 | 63.0 | 110.1 | 31.8 | 64.5 | 28.7 | 26.0 | 32.0 | 91.6 | 1500 |
| 1 1/2" Sq. | 181.0 | 102.0 | 153.7 | 43.8 | 86.5 | 50.7 | 39.3 | 51.0 | 136.0 | 5700 |

Crane Electronics Ltd
The force in torque management

Torque Data Collectors

Crane's torque data collectors allow for the accurate measurement and collection of torque, angle, pulse, peak, force and many other forms of data in the manufacturing and quality environment, including the renowned TorqueStar range and the IQVu and IQVu plus.

The TorqueStar range is the equipment of choice for the measurement and collection of torque, angle, pulse and force data. The range offers differing levels of software features that can be individually specified to give a configuration which is most suited to the requirement, from a simple no-frills readout to a comprehensive audit tool with display of torque or force curves and specialist measurement routines.

The IQVu and IQVu *plus* are one of the most revolutionary torque data collectors in the world. They combine all of the features of the established TorqueStar with a market-leading, robust tablet to give a modern and familiar product, providing the ideal solution for the manufacturing and quality environment.



Crane Electronics Ltd
The force in torque management

TorqueStar Lite

Torque Indicator and Data Collector

The TorqueStar Lite is the latest basic torque data collector in the revolutionary TorqueStar series, offering a simple and easy-to-use solution for the measurement and collection of torque data. The TorqueStar Lite is ideal for users who want a quick and straight-forward 'plug-and-play' product with the added precision that the Crane Electronics brand guarantees.



- ✓ Multiple measurement modes including **track, peak, pulse** and **click**.
- ✓ **Strong, durable and robust**, perfect for the manufacturing and quality environment.
- ✓ **Simple setup and easy operation** for a clear and concise torque measurement process.
- ✓ Includes a **white OLED screen** for basic torque data readings and alerts.
- ✓ **LED torque status** indicators with audible buzzer notification.
- ✓ Long battery life and **up to 999 readings** available in storage.

Function Keys



Measurement Modes

Switch between numerous measurement modes.



Delete

Clear/Remove selected results and data.



View

Quick view of the readings list.



Statistics / Results

View all of the current collected data results.



Settings

View and edit the TorqueStar Lite settings.

OLED Screen

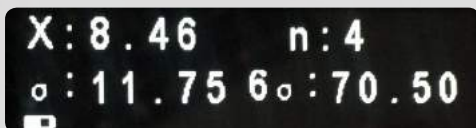
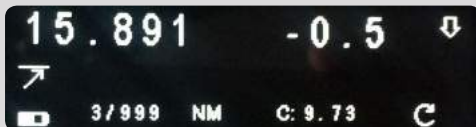

The clear and sharp screen on the TorqueStar Lite enables easy-to-view data, readings and statistics. It also has an added screen-saving ability to ensure there is no screen burn-in damage. Function keys allow the user to quickly scroll between different mode screens.

Technical Specifications - TorqueStar Lite

| | |
|---------------------------------|--|
| Measurement Units | Torque: Nm, lbft, lbin, MNm, Ncm, kgcm, kgm, kNm, klbft, Nmm, ozin |
| Measurement Modes | Track, Peak, Pulse, Click |
| Data Storage | 999 Readings in storage mode |
| Basic Statistics | Count, Range, Mean, Min, Max, Standard Deviation |
| Auto-Print / Data Output | Easy selectable output to Auto-Print |
| Cycle Status Indication | Audible buzzer and LED Hi/OK/LO torque status. All user definable |
| Operating Language | Czech,English,French,German,Hungarian,Italian,Spanish,Swedish,Polish,Portuguese,Turkish |
| Construction | High strength injection moulding and soft rubber trim Tough internal chassis (can survive 1.8m drop) White OLED Display - 79mm x 21mm Easy clean keypad - 11 keys including 5 function keys |
| Battery & Power | Lithium Ion - User swappable 3 hours charge time via USB or Universal 5V charger |
| Power Management | User selectable auto power-off: between 0 - 200 minutes |
| Input / Output Ports | 25 pin 'D' type transducer Port, Basic USB (2.0) Micro 5V DC Power Port |
| Zero Stability | 0.01% FSD/ °C |
| Static Accuracy | ± 0.25% FSD of connected transducer |
| Operating Environment | Temperature: -20 to +50 °C Humidity 10-75% non-condensing Ingress protection rating: IP45 |
| Angle Measurement | Display angle to 0.1 degrees, Sample every 1000 micro seconds |
| Warranty | 12 months parts and labour against faulty workmanship or materials |
| Accessories | Neck Strap |

Crane Electronics Ltd
The force in torque management

TorqueStar Pro & Plus

Torque Indicator and Data Collectors

The TorqueStar Plus and Pro are the latest innovations from Crane Electronics in torque management. The Plus and Pro add a completely updated and fresh-looking torque indicator and data collector to our current product portfolio.

With a whole host of measurement modes available, a series of basic and advanced statistics, visual graphical analysis, high-quality backlit screen and expansive storage; the TorqueStar Plus and Pro model really do offer a complete solution for all budgets and applications in the manufacturing and quality environments.



- ✓ Numerous measurement modes including **track, peak, pulse, click, audit, move-on, re-tighten** and **yield**.
- ✓ **Strong, durable and robust**, perfect for the manufacturing and quality environment.
- ✓ A **full-colour backlit screen** for clear and concise torque measurement.
- ✓ Both ranges are compatible with **label printers**, connected via USB port.
- ✓ The **TorqueStar Pro** has the capability to add '**jobs**', '**rounds**' & **advanced statistics** to your measurement process.
- ✓ **TorqueStar Pro** is also compatible with our own torque management software packages, **OMS** and **OMS Lite**.
- ✓ **TorqueStar Pro** also offers **torque traces** and **RF comms** to connect to our WrenchStar Multi and CheckStar Multi via RFm.



Crane Electronics Ltd
The force in torque management



Real-time data capture

The clear screen on the TorqueStar Plus & Pro allows for easy-to-view torque measurements. Colour-coded statistics give the operator all the required information on one screen.



Easy to navigate

The simple menu and page structure allows for easy navigation and straight-forward use. The clear values and readings within all measurement modes improves the user experience.



Torque traces & graphical analysis

The TorqueStar Pro allows the user to view torque traces on the screen, to visualise the torque data measurement process.

Graphical Analysis also delivers a more in-depth examination of vital assembly data. 'zoom', 'change axis', 're-size', 'move' and USB trace export available on both units, with the addition of 'trend' available on the TorqueStar Pro.



Jobs, rounds & advanced statistics

The TorqueStar Pro includes the addition of preset 'jobs' and 'rounds' (groups of jobs) for increased efficiency. Advanced statistics allows the user to review results in detail and improve processes.

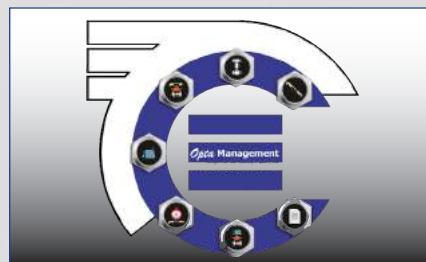

OMS software compatibility

The TorqueStar Pro is compatible with Crane's torque management software system, OMS. This allows data to be collated and transported to the customer's system, offering a company-wide solution for torque management.



Technical Specifications - TorqueStar Plus & Pro

| | | Plus | Pro |
|--------------------------------------|--|------|-----|
| Measurement Units | Torque: Nm, lbft, lbin, MNm, Ncm, kgcm, kgm, kNm, klbft, Nmm, ozin | X | X |
| Measurement Modes | Track, Peak, Pulse, Click, Force, Audit | X | X |
| | Move-On, Yield, Re-tighten | | X |
| Data Storage | 999 Readings in storage mode | X | X |
| | 16GB Storage - Internal Micro SDHC | * | X |
| Basic Statistics | Count, Range, Mean, Min, Max, Standard Deviation | X | X |
| Advanced Statistics | Cm, Cmk, Cp, Cpk | * | X |
| Jobs & Rounds | Capability and storage and jobs and rounds data | | X |
| Auto-Print / Data Output | Easy selectable output to Auto-Print (via USB Cable) or CSV (via USB Flash Drive) | X | X |
| Cycle Status Indication | Audible buzzer and LED Hi/OK/LO torque status. All user definable | X | X |
| Graphs & Graphic Analysis | Zoom, Change Axis, Resize, Move, Trend (Pro only), Export Trace to USB Flash Drive | * | X |
| Operating Language | Chinese,Czech,English,French,German,Hungarian,Italian,Spanish,Swedish, Polish,Portuguese,Turkish | X | X |
| Construction | High strength injection moulding and soft rubber trim | X | X |
| | Tough internal chassis (can survive 1.8m drop) | X | X |
| | Backlit LCD colour display - 86mm x 52mm (4") | X | X |
| | Easy clean keypad - 11 keys including 5 soft keys | X | X |
| Battery & Power | Lithium Ion - User swappable | X | X |
| | 3 hours charge time via USB or Universal 5V charger | X | X |
| Power Management | User selectable auto power-off: between 0 - 200 minutes | X | X |
| | Brightness adjustment | X | X |
| Input / Output Ports | 25 pin 'D' type transducer Port, Basic USB (2.0) Micro | X | X |
| | Standard USB OTG, 5V DC Power Port | X | X |
| Printer Compatibility | Serial Printer (via USB) | X | X |
| Zero Stability | 0.01% FSD/ °C | X | X |
| Static Accuracy | ± 0.25% FSD of connected transducer | X | X |
| Operating Environment | Temperature: -20 to +50 °C | X | X |
| | Humidity 10-75% non-condensing | X | X |
| | Ingress protection rating: IP45 | X | X |
| Angle Measurement | Display angle to 0.1 degrees, Sample every 1000 micro seconds | X | X |
| Warranty | 12 months parts and labour against faulty workmanship or materials | X | X |
| Accessories | Protective Case | | X |
| | Neck Strap | X | X |
| Barcode Capability | Optional | | X |

*Optional Upgrade.

Crane Electronics Ltd
The force in torque management

IQVu & IQVu *plus* Torque Data Collector

The IQVu is the most revolutionary torque data collector in the world. It combines all of the features of the established TorqueStar with a market-leading, robust tablet, to give a modern and familiar product. It provides the ideal solution for the measurement and collection of torque, angle, and pulse data in the manufacturing and quality environment.

The tablet is sleek and thin, yet tough, certified to a 1.8m (6') drop rating along with IP65 ingress protection. It has been carefully engineered, down to the chassis, to be protected against drops, shocks, spills, vibration and more. The screen of the IQVu uses tempered glass and features LumiBond™ optical bonding. This results in a display that is not only extremely robust and scratch-resistant, but also very durable and easy-to-read in most lighting conditions.

The comprehensive audit tool performs bi-directional measurement in Peak, Click, Pulse, MoveOn, Yield and Track measurement modes. The "Quick Check" function allows the operator to take measurements as required. Work can be scheduled using 'Jobs' and 'Rounds' to allow a planned approach to collecting data. Input of information is either via the soft keypad on the screen or downloaded from OMS Software. The IQVu can also be interfaced with a customer's existing data management system.



Key Features

- ✓ High resolution colour display made from fully rugged & tempered "Gorilla" glass
- ✓ Peak, Click, Pulse, MoveOn, Yield and Track measurement modes
- ✓ Torque, angle and impulse count plus RPM
- ✓ Upper and lower specification limits, plus control limits for torque and angle
- ✓ Display of real time torque curves
- ✓ Time and date stamped readings
- ✓ Communicates with your PC system



| | |
|---------------------------------|--|
| Ports: | 25-pin female D-type for transducer connection. DC Power port mains power and charging batteries. USB port to accept connection to PC or USB memory stick. SD card slot. Communications USB ver 2.0 (host and client), Bluetooth (v2.1+EDR class 2), WLAN 802.11 b/g/n |
| Barcode: | Optional Reader available |
| Operating Temperature: | -20°C to +50°C |
| Humidity: | 10-75% non-condensing. |
| IP Rating: | Tablet is MIL-STD-810G and IP65 certified |
| Warranty: | 2 years parts and labour against faulty workmanship or materials. The second year of warranty is only valid if the unit has been recalibrated at an authorised Crane Electronics Service Centre after the first year |
| Dimensions/Weight: | 218mm x 162mm x 44mm, 1040gm (including handstrap) |
| DC Tool connection: | The IQVu can talk to a DC tool controller using Open Protocol over Wi-Fi and associate the tool reading with a reading from transducer |
| Physical measurements: | Bi-directional torque and angle*; Pulse count, Pulse rate; RPM* (*when using a rotary torque transducer with angle encoder in Track mode) |
| Measurement Units: | Nm, Ncm, lb ft, lb in, oz in, kNm, klb ft, kg m, kg cm |
| Measurement Modes: | Peak, Click, Pulse, MoveOn, Yield and Track |
| Automatic Transducer: | Torque range, angle encoder PPR, transducer serial number, calibration due date recognition torque@2mV/V (CheckStar Multi only) |
| Types of Transducer: | CheckStar Multi, UTA and IS (CheckStars and Wrenches) |
| PC compatibility: | Communicates with OMS and Opta Comms |
| Data storage: | 16GB storage, Micro SDHC (up to 32GB) slot |
| Processor: | 1GHz Dual Core Processor |
| Operating system: | Android 4.1 |
| Statistics: | Count, Mean, Standard Deviation, Range |
| Print: | Wi-Fi printer (TBC) |
| Display: | 7.0" TFT LCD WSVGA, 1024 x 600 pixels resolution, adjustable brightness. Touch-sensitive with gloves worn. Tempered glass featuring LumiBond® |
| Cycle status indicators: | Colour, Sound and Vibration (all user definable). External light ring indication on CheckStar Multi |
| Graph of tightening: | Available in realtime, resolution down to 1mS. Zoom feature available. Trace: Torque vs Time (default), Angle versus Time and Torque versus Angle |
| Operating language: | English; French; German; Spanish; and Chinese - Toggle between multiple languages |
| Transducer calibration: | Transducer out of calibration warning |
| Construction: | Soft rubber trim surrounding tough internal chassis. Tablet will survive 1.8m (6 ft) drop |
| Torque measurement: | 5 digit display with resolution to 0.006% of Transducer span. Sampled every 20 micro seconds (50,000 per second) |
| Zero stability: | < 0.1% FSD / °C |
| Static accuracy: | +/-0.25% FSD of connected Transducer |
| Angle measurement: | Display angle to 0.01 degrees. Sample every 1,000 micro seconds. Adapts to PPR of angle. Transducer using quadrature phase measurement. |
| Security: | IQVu protected by SOTI MobiControl, which allows preset control of downloads and uploads to the device. Multiple user logins with password protection. |
| Frequency response: | User selectable 75Hz to 5000Hz low pass Bessel Filter is employed for conditioning the transducer signal to eliminate 'noise' from tool measurement. |
| Power: | International Charger 12V @ 2 A from 100-240VAC; 50/60Hz. |
| Batteries: | Internal Lithium Polymer battery pack with 7600mAh capacity. 8-hour shift with normal usage. The IQVu <i>plus</i> model comes with additional external battery pack allowing for continued use with a battery management system. |

Crane Electronics Ltd
The force in torque management

| Name | S/N | Type | Span, Nm | Port | PPR | Battery |
|-------------|-------|------|----------|------|------|---------|
| 75Nm T&A | 77307 | 0 | 75 | 2 | 180 | N/A |
| 75Nm T&A | 86635 | 0 | 75 | 3 | 720 | N/A |
| 180Nm T&A | 91996 | 0 | 180 | 4 | 180 | N/A |
| 10Nm T Only | 12345 | 0 | 10 | 5 | 180 | N/A |
| ---- | ---- | ---- | ---- | RF1 | ---- | ---- |
| ---- | ---- | ---- | ---- | RF2 | ---- | ---- |
| ---- | ---- | ---- | ---- | RF3 | ---- | ---- |

Transducers

- ✓ Designed to work perfectly with the CheckStar Multi
- ✓ Compatible with in-line UTA & IS rotary torque transducers
- ✓ Torque, angle and pulse count
- ✓ Setup user defined names for all connected transducers
- ✓ Automatic recognition of Crane transducers

| Job | Reading type | Compatible | Done |
|---|--------------|------------|------|
| FL15 [Front left wheel] 2014-08-07 14:56:40 <small>[Name: Txd; Txd: SN 90595; Completed: 0]</small> | Click | ✓ | ✗ |
| FR15 [Front right wheel] 2014-08-07 14:56:43 <small>[Name: Txd; Txd: SN 90595; Completed: 0]</small> | Click | ✓ | ✗ |
| RTB [Right trunk bolt] 2014-08-07 15:00:27 <small>[Name: Txd; Txd: SN 90595; Completed: 0]</small> | Peak | ✓ | ✗ |
| MB15.5 | | | |

Jobs

- ✓ Assign photos and instructions to 'Jobs'
- ✓ Simply add a name to convert Check measure into a 'Job'
- ✓ Clear and simple 'Job' list including progress monitor
- ✓ Download 'Jobs' from PC via existing Crane PC Software
- ✓ Sort 'Jobs' into 'Rounds'
- ✓ Provide statistical analysis

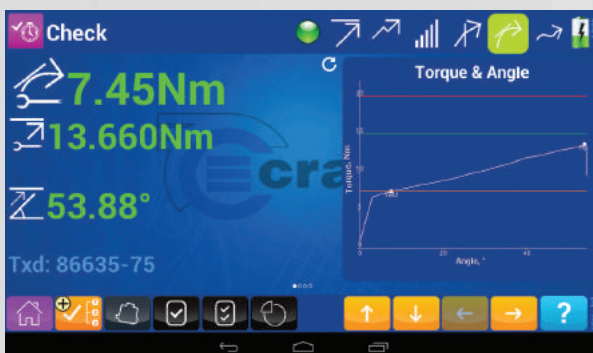

Check Measure

- ✓ Take measurements with minimal key presses
- ✓ 1-click change between measurement modes
- ✓ Large display with reading values & rundown trace
- ✓ Peak, Click, Pulse, MoveOn, Yield, Track measure modes
- ✓ Zoom into trace
- ✓ Save details to USB/email

Settings: 8/9 Readings

Reading type

Track Frequency: 384 Hz Update graph freq, ms: 100

Peak Frequency: 542 Hz Update values freq, ms: 100

Click Frequency: 768 Hz Immediately start saving readings every, count: 1

Reading timeout, s: 120

Use Peak angle Final angle Factory mode

Settings and Users

- ✓ Easily configure global settings
- ✓ Add users with permissions, access rights & photos
- ✓ Password protection available
- ✓ User selectable languages
- ✓ Trace readings to user
- ✓ Easy backup and restore of settings

Crane Electronics Ltd
The force in torque management

Digital Torque Wrenches

Crane specialises in torque wrenches for production, quality & auditing applications in numerous manufacturing industries. The IQWrench2 Opta & WrenchStar Multi torque wrenches enable the digital recording of torque data, perfect for logging and tracing vital information.

Manufactured in the UK, our range of electronic torque wrenches connect seamlessly with our market-leading torque data collectors for recording torque and angle data.

The WrenchStar Multi digital torque wrench is for customers who require torque and angle data to be recorded electronically. The WrenchStar Multi has a 360° light ring that is completely visible at any angle and the torque wrench can be used wirelessly or with a cable option.

The IQWrench2 Opta combines all of the features of a high specification digital torque wrench with a built-in torque data collector system in one ergonomic, versatile and incredibly powerful package.



IQWrench 2 Opta Intelligent Digital Torque Wrench

The IQWrench2 combines all of the features of a high specification digital torque wrench with a data collection system in one ergonomic, versatile and incredibly powerful package. Its software can also be upgraded at any time to give greater flexibility. Basic to advanced versions are available depending on the customer's application and requirements. A barcode reader and RF wireless transfer version are also available. Its robust design and rugged construction is suitable for harsh production environments.

The IQWrench2 has easy selection of quick release interchangeable ID heads. The Crane auto ID system can be fitted to standard DIN heads and offers up to 999 unique IDs programmed into OMS. The use of available automatic digital ID heads ensures a highly accurate reading every time. ID heads can also be used for automatic Job selection which minimizes the input required by the operator.

IQWrench2 operates at a user-programmable RF frequency of 868/915MHz according to country of installation. This allows for data transfer from the wrench to PC/PLC and integration into the OMS software system to collect production data against multiple 'Jobs'. RF also allows for the remote selection and transfer of Jobs to the wrench and for integration into 3rd party systems.

The IQWrench2 features an optional barcode reader capable of scanning all major 1D barcode formats allowing the user to access Job or Round selections, access user details to login and store against the data, and also link data to the part/VIN number on an assembly.



Key Features

- ✓ Torque range of 0.5 to 1500Nm
- ✓ Torque and angle measurement technology
- ✓ Vibrating handle giving a clear indication of fastener status
- ✓ Advanced software: RF communication, barcode, MoveOn, Trace, Yield
- ✓ Head type versions: SR, fixed, DIN interfaces to Crane OMS software
- ✓ Job/Rounds settings

IQWrench2 Technical Specification:

| | |
|--------------------------------|---|
| Measurement units: | Nm, Ncm, kgfcm, kgfm, ozin, lbin, lbft (depends on span) |
| Measurement modes: | Track, Peak (Auto-reset), Angle, Yield, Audit, MoveOn |
| Data storage: | 200 reading memory of both parameter values with time and date stamp Up to 50,000 readings in job store mode Up to 50 graphs |
| Printer compatability: | Via RS232 output: 40/80 columns English; German; French; Spanish; Italian; Swedish; Czech; Portuguese; Turkish |
| Construction: | Shaft material: Steel Housing: Aluminium Overload capacity: 125% of rated torque Square drives fitted with pin and spring socket retainer DIN sockets with quick release function |
| Display: | Backlit graphic LCD display with backlight auto off to save power |
| Zero stability: | < ± 0.1% FSD/°C |
| Static accuracy: | ± 0.5% FSD |
| Operating Environment: | Temperature: +5°C to +40°C Ingress protection rating: IP40. Can be used outdoors |
| Optional Angle measure: | +/- 1% |
| Warranty: | 12 months parts and labour against faulty workmanship or materials |

| | | Torque Range | | | Length* | | Weight | |
|-------|--------------|--------------|------------|-------|---------|--------|--------|-------|
| Size | Head | Nm | lbft | Drive | mms | inches | gms | lbs |
| 10/25 | Fixed or Din | 1-25 | 0.74-7.4 | 1/4" | 313 | 12.32 | 890 | 1.96 |
| 10/25 | Din | 1-25 | 1.8-18.4 | 1/4" | 368 | 14.49 | 960 | 2.12 |
| 75 | Din | 7.5-75 | 5.5-55.3 | 3/8" | 382 | 15.04 | 1030 | 2.27 |
| 180 | Din | 18-180 | 13.2-132.7 | 1/2" | 660 | 23.62 | 1546 | 3.41 |
| 340 | Din | 34-340 | 25-250.6 | 1/2" | 775 | 30.51 | 2012 | 4.44 |
| 600 | Din | 60-600 | 44.2-442.5 | 3/4" | 1100 | 43.31 | 3500 | 10.36 |
| 750 | Fixed | 75-750 | 55.2-552.7 | 3/4" | 1165 | 45.87 | 5600 | 12.35 |
| 1500 | Fixed | 150-1500 | 110.5-1105 | 1" | 1908 | 75.12 | 10900 | 24.03 |

WrenchStar Multi Digital Torque Wrench

The WrenchStar Multi digital torque wrench is perfect for users who require torque and angle data to be digitally recorded via a reliable, versatile and robust torque wrench.

The WrenchStar has a clear OLED display screen to view the current task information, combined with a 360° light ring that is completely visible at any Angle plus a vibration alert to indicate results.

The WrenchStar Multi works in combination with our revolutionary IQVu torque data collector or our TCI lineside controller via either an RF wireless connection or via a cable. Together, they are a perfect solution to accurately measure and tighten critical fasteners to your preset torque specifications.

For versatility, if the digital torque wrench goes out of range of its paired controller, it can continue to collect data with storage for up to 200 readings, allowing you to work offline. Once back in range, the WrenchStar Multi then automatically connects to the IQVu or TCI and communicates with and downloads the data.

Key Features

- ✓ 360° light ring displaying the colour status of readings and vibration alert
- ✓ Can be used wirelessly (RF) or with a cable option
- ✓ Quick change battery pack for extended shift time use – chargeable internally & externally
- ✓ Interchangeable heads with ID for auto length compensation
- ✓ OLED display that is clear and bright
- ✓ Capable of recording up to 200 readings offline before having to return to the data collector
- ✓ Compatible with the most advanced torque data collector the IQVu and our TCI lineside controller



Crane Electronics Ltd
The force in torque management

WrenchStar Multi Technical Specifications:

| | |
|--------------------------------------|--|
| Operating temp range: | -20 to +50°C |
| Storage temp range: | -20 to +50°C |
| Humidity: | 10-75% non-condensing |
| IP Rating: | IP40 (Indoor use only) |
| Reading storage: | 200 readings |
| Sampled: | Every 20 micro seconds (50,000) per second |
| Zero Stability: | <0.1% FSD/°C |
| Static Accuracy: | ±0.25% FSD |
| Angle Measurement: | Sample every 1000 micro seconds |
| Frequency Response: | 75Hz to 4608Hz |
| Battery: | Rechargeable 3.7v Lithium Ion |
| Capacity: | 2600mAh |
| Communication with IQVu plus: | 2.4GHz RF & Cable |
| Communication with TCI: | 2.4GHz RF with Open Protocol or Crane Protocol |

| Sales Code WSM plus Battery and Cradle | Range | Insert | Weight (gr) | Length (mm) |
|--|-------------------|-------------|----------------|----------------|
| WS1JX-0010-C1DARX | 10Nm DIN Insert | 9X12 mm | 833 | 380 |
| WS1AX-0010-C1FARX | 10Nm Fixed Head | | 720 | 330 |
| WS1JX-0025-C1DARX | 25Nm DIN Insert | | 904 | 380 |
| WS1AX-0025-C1FARX | 25Nm Fixed Head | | 725 | 330 |
| WS1JX-0075-C1DARX | 75Nm DIN Insert | | 914 | 395 |
| WS1JX-0120-C1DARX | 120Nm DIN Insert | | 967 | 395 |
| WS1KX-0180-C1DARX | 180Nm DIN Insert | 14x18 mm | 1474 | 613 |
| WS1KX-0250-C1DARX | 250Nm DIN Insert | | 1710 | 640 |
| WS1KX-0340-C1DARX | 340Nm DIN Insert | | 1925 | 788 |
| WS1KX-0500-C1DARX | 500Nm DIN Insert | Fixed | 3173 | 887 |
| WS1DX-0750-C1FARX | 750Nm Fixed Head | | 5279 | 1178 |
| WS1FX-1000-C1FARX | 1000Nm Fixed Head | | 8527 | 1433 |
| WS1FX-1500-C1FARX | 1500Nm Fixed Head | | 10377 | 1921 |

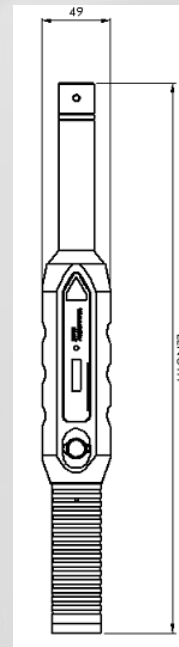

Crane Electronics Ltd
The force in torque management

Tool Torque Stations

Crane specialises in the supply of complete tool torque stations including standard and bespoke kitted Mobile Tool Torque Stations (MTTS) and the threaded Joint Rate Simulator (tJRS) bench.

The MTTs is a portable tool station which also provides a reliable platform and surface to test the torque readings of your tools at the side of the production line and a useful storage trolley for all of your tools and torque testing equipment. The MTTs is compatible with the complete range of torque management and measurement tools from Crane Electronics and can be supplied as a simple tool station or equipped to your specifications.

The tJRS is the only fully automated joint simulator that is based on a threaded fastener. Combining all of Crane's innovative torque tools and techniques provides the user with complete confidence in the results of their tool testing.



Crane Electronics Ltd
The force in torque management

MTTS

Mobile Tool Torque Station

The Mobile Tool Torque Station (MTTS) is a portable tool station which also provides a reliable platform and surface to test the torque readings of your tools at the side of the production line and a useful storage trolley for all of your tools and torque testing equipment.

The MTTS is compatible with the complete range of torque management and measurement tools from Crane Electronics and can be supplied as a simple tool station or equipped to your specifications.

The Mobile Tool Torque Station is perfect for the measurement of all continuous drive, impulse and hand torque tools.



Key Features

- ✓ Solutions for various torque ranges from 0.2Nm upwards
- ✓ Line-side tool testing
- ✓ Flexible design and easy to manoeuvre
- ✓ Optional rotary or static torque transducers, joint kits or torque data collectors
- ✓ Can be customised with barcode scanners, printers and various screen and panel options
- ✓ Can be configured to communicate with your system or Crane's OMS torque software.



Crane Electronics Ltd
The force in torque management

The MTTs can be supplied as a simple, stand alone torque tool station or it can be configured to your specifications with a bespoke finish, utilising our torque transducers, data collectors, joint kits and torque Software.

All MTTs trolleys are supplied with a lockable compartment for safe tool storage and with a robust handle for easy pushing, pulling and manoeuvring.



Crane Electronics Ltd
The force in torque management

tJRS Joint Test Bench Threaded Joint Rate Simulator

The tJRS Opta is the only fully automated joint simulator bench that is based on a threaded fastener. This means that joint conditions can be set up in the same way as real fastener applications, and also the joint can be automatically “backed off”. As a result, tools can be tested offline under the most realistic conditions of any automated joint simulator, in a quick and efficient manner.

The tJRS Opta combines many of Crane’s proven industry leading products along with innovative techniques based on simple mechanical principles, allowing the user complete confidence in the results of their tool testing.

Traditionally, automated joint simulators have used friction brake systems in place of a threaded fastener. The reasons for this were to overcome the two main issues which are having to reverse, or “back-off”, after each rundown and the cumbersome nature of reconfiguring the joint characteristic. Whilst friction brakes can easily be reset, removing the back off issue, they introduce many of their own problems often resulting in the simulator having significantly different properties to actual joints the tools will be used on.

The revolutionary tJRS Opta combines the benefits of using a threaded fastener with the convenience of a fully automated simulator.



Key Features

- ✓ Fully automated quick release of fastener
- ✓ Fully automated variable joint rate from ‘Soft’ to ‘Hard’
- ✓ Torque or force indicator and data collector
- ✓ Automatic greasing facility
- ✓ Comprehensive management software (OMS)
- ✓ Torque, angle and impulse count and Track, Peak, 1st Peak (click) and Pulse measurements
- ✓ 8 hours battery life with internal charger



tJRS Opta Technical Specification:

| | |
|---------------------------|---|
| Measurement units: | <p>330Nm tJRS Opta Maximum torque: 330Nm Minimum torque: 1Nm</p> <p>500Nm tJRS Opta Maximum torque: 500Nm Minimum torque: 1Nm</p> <p>1000Nm tJRS Opta Maximum torque: 1000Nm Minimum torque: 1Nm</p> |
| Weight: | Depends on configuration |
| Beams: | <p>500Nm tJRS Opta 500Nm, 100Nm and 10Nm beam</p> <p>1000Nm tJRS Opta 1000Nm, 330Nm and 25Nm beam</p> |
| Bolts and Nuts: | <p>Bolts and nuts are replaceable and removable from the top Each bolt, thread and under collar nut has its own automatic greasing system</p> <p>Adaptors provided to connect the transducer to the nut on the bolt</p> |
| TorqueStar Opta: | Standard TorqueStar Opta with Opta Management Software automatically selects the required CheckStar |
| CheckStar: | <p>Each CheckStar has a military connector allowing it to be removed The tJRS Opta identifies which CheckStar Opta and beam are being used</p> <p>500Nm tJRS Opta $\frac{3}{4}$" drive rotary UTA with angle for use on the 500Nm beam $\frac{1}{2}$" drive rotary UTA with angle for use on 100Nm beam $\frac{1}{4}$" drive rotary UTA with angle for use on 10m beam</p> <p>1000Nm tJRS Opta 1" drive rotary UTA with angle for use on the 1000Nm beam $\frac{1}{2}$" drive rotary UTA with angle for use on 330Nm beam $\frac{3}{8}$" drive rotary UTA with angle for use on 25m beam</p> |
| Dimensions: | <p>330Nm & 500Nm tJRS Opta 1100mm (1200mm including handle) x 600mm x 940mm (L x W x H) Base above floor = 230mm</p> <p>1000Nm tJRS Opta 1400mm x 700mm x 940mm (L x W x H) Base above floor = 140mm</p> |
| Reaction posts: | <p>Standard reaction posts at appropriate positions that can take the forces generated by the torque The posts will slide fit in their holders for ease of use</p> |

| | |
|-----------------------|---|
| Mounting: | <p>330Nm & 500Nm tJRS Opta On 4 wheels: 2 fixed, 2 swivel with brakes Wheel diameter 200mm</p> <p>1000Nm tJRS Opta On a carrier that can accept pull truck or be left in a fixed location Mounted on 4 feet</p> |
| Surface: | Oil-resistant engineering plastic |
| Power/Battery: | <p>Powered by 2 x 12V sealed lead acid batteries that gives approximately 8 hours of typical use on a full charge</p> <p>Internal battery charger is fitted to charge batteries in 10 hours from a 100 - 240V mains voltage</p> <p>Operates when the batteries are being charged</p> <p>PC receives power from the internal batteries, but if mains voltage is available, then this will be used instead to conserve battery charge</p> <p>Self-powered USB hub with 4 connections is provided for peripherals to be attached to the PC</p> |
| Hydraulics: | <p>Working pressure is 200 bar</p> <p>Smaller beams work at lower pressure</p> <p>Hydraulic washers take the clamp load and will be used to release the clamp load at the end of the tightening</p> |
| Controller: | <p>Touch panel PC with solid state hard drive</p> <p>Single licence of OMS for standalone use on the tJRS</p> <p>OMS modules and SQL database</p> <p>Threaded JRS controller</p> |
| Operation: | <p>Follows the guidelines in VDI/VDE 2647</p> <p>A traffic light system operates to inform the operator when to run down the tool</p> <p>There are safety mechanisms in case the operator ignores the NO GO signal</p> <p>Peak, Impulse and Click testing are permitted on the beam Joints</p> <p>The operation time allows 30 rundowns in 3 minutes dependent on tool and joint type selected</p> <p>The joint is automatically reset without the tool needing to be removed</p> |
| Environment: | <p>Operates between +10C and +30C</p> <p>Indoor use only</p> |
| Product codes: | <p>TJMXX-0330-CRJEXX 330Nm tJRS Opta</p> <p>TJMXX-0500-CRABCX 500Nm tJRS Opta</p> <p>TJ3FX-1000-CR01XX 1000Nm tJRS Opta</p> |

Crane Electronics Ltd
The force in torque management

The tJRS Opta system removes the need to reverse the fastener, or remove the tool drive during the back off process. This makes it an ideal tool for improving the efficiency of tool certification. It is particularly important when testing higher torque tools, many of which do not have a reverse gear.

Another major advantage of using a joint simulator is the ability to change the joint conditions through a software interface rather than time-consuming mechanical re-configuration. Crane has pioneered the use of its patented twin beam systems using high quality precision materials.

This not only simplifies the setup process, but also provides the user with an incredibly linear and repeatable test facility. As the joint conditions are stored in the database against each tool, the user can also be assured that the same conditions are recalled whenever a given tool needs testing.

The linearity and repeatability of the tJRS Opta follows the guidelines in VDI/VDE 2647 - "Transducers for nutrunning systems – Guideline for dynamic checking of tools according to ISO 5393". The tJRS Opta is designed with the latest 3D solid modelling tools and built on Crane excellence.

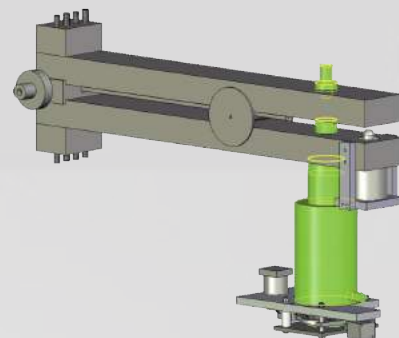

The tJRS Opta is a modular system which allows the user to select from a number of torque ranges or beams. This ensures the configuration of a unit which best meets customer requirements. The modular design also enables specific custom units.

For units with multiple beams, the tJRS Opta automatically selects the transducer to use and informs the operator via a clear graphical notification. For an even greater degree of control when testing tools that are particularly susceptible to excessive inertia, or when tools have non-standard drive sizes, the transducer on the beam can be changed for a more suitable size. This ensures the user is always using the appropriate device and removing the need for drive adapters that often cause inaccuracies.

The tJRS Opta can either be configured as a stationary unit or mounted on wheels to provide mobile operation. The onboard batteries are designed to give a full shift of normal operation on a single charge.

In addition to the mobile operation, tJRS Opta also allows the operator to use in-line transducers and the readout to certify tooling in-situ when it cannot be readily accessible for testing directly on the simulator. This ensures all tool management is performed in correspondence within the same database.

Crane Electronics Ltd
The force in torque management

Torque Software

Crane's Opta Management System (OMS) software packages feature a range of functions that help provide a complete company-wide solution to all torque-related activities including tool and joint management, tool maintenance history, torque auditing, data collection, bespoke reports and much more.

We can provide a solution to fit your company system to help provide a completely tailored solution for managing your torque tool data and critical quality data that must be recorded, stored and protected.

As part of our torque software offering, we can supply our full OMS software package which includes all aspects and capabilities possible, or we can supply you with OMS Lite, which includes just the core capabilities required for simple torque data management.



OMS Software Torque Software

OMS features a range of functions to provide a complete company-wide solution to all torque-related activities including tool and joint management, tool repair/maintenance histories, quality torque auditing and production data, and transducer/readout calibrations. In addition, OMS allows the user to generate a series of bespoke reports and records.

Calibration and scheduled re-calibration dates for production tools and auditing devices can also be managed maintaining not only an efficient and traceable record, but providing the user with an effective management tool to view upcoming work. OMS allows the user to track the location of tools by assigning them to processes (joints). It also offers the facility to certify tools.

Tool management within OMS enables the user to track both in-house or 3rd party repair/maintenance records and associated costs for assembly and audit tools. This allows the user to configure Jobs and Rounds. Used in conjunction with any of the Crane family of products OMS provides the perfect quality system for periodic sampling of both residual and dynamic torque/angle measurements.

A key and unique feature in OMS is the custom report module. The user can select any field(s) within the database and create their own custom reports, tying together data to produce bespoke management information. This powerful tool provides the user with unprecedented access to their data, cost and efficiency tracking of tools, workload scheduling and traceable calibration/certification records in addition to in-depth data analysis.



Key Features

- ✓ Single database to store all torque information
- ✓ Cross reference production, quality and tooling information
- ✓ All Data completely traceable and secure
- ✓ User-friendly operation with intuitive icons (click or touch)
- ✓ Tool management inc. repair/service history
- ✓ Management of production & audit tools
- ✓ Advanced report generator

Crane Electronics Ltd
The force in torque management

Torque Testers

Crane offers a range of basic, easy-to-use torque testers for the simple measurement, collection and storage of torque data. Torque testers capture peak torque and also display simple torque measurement in real-time on a small display. These are particularly popular where tool torque measurements are required to ensure a general torque level is being reached, without the advanced capabilities that a full specification torque data collector offers.

Our range of torque testers includes the ReadStar TT and also the CapStar II torque tester built specifically for applications in the food, beverage bottling and pharmaceutical industries.



ReadStar TT

Torque Tester

The ReadStar TT is a basic, easy-to-use readout which allows measurement and collection of torque data, with storage of up to 200 readings and built-in torque transducer. The multilingual software and consistent interface ensures ease of use.

This product has a variety of modes and can measure Track, Peak, 1st Peak (Click) and Pulse. Results are shown on an easy read display. Time and date stamped readings can be set to print automatically.

The ReadStar TT can be powered using "C" cells, rechargeable batteries, or from the mains. The batteries must be recharged externally to the product (charger not provided). It can also either be fixed permanently or used as a portable device.

Key Features

- ✓ Accurate and simple to operate
- ✓ Robust but lightweight unit
- ✓ Tricolour LED identification of torque status
- ✓ 200 date and time stamped reading memory
- ✓ Download data to a PC or Printer
- ✓ Available in sizes 1Nm, 4Nm or 30Nm



CapStar II Torque Tester

The CapStar II torque tester is a simple and easy to operate digital torque tester specifically designed for usage in the pharmaceutical, food & beverage and cosmetic industries.

The ability to accurately measure the release torque on a bottle and container closures is an essential discipline to meet the required torque for child-resistant closures, whilst ensuring the end user can open the product and that product freshness is maintained.

The multilingual software and consistent interface ensures ease of use when working with external torque transducers. The CapStar II has a variety of modes and can measure Track, Peak, 1st Peak (Click) and Pulse. Results are shown on an easy read display. Time and date stamped readings can be set to print automatically.

The CapStar II can be powered using "C" cells, rechargeable batteries or from the mains. The batteries must be recharged externally to the product (charger not provided). The CapStar II can either be fixed permanently or used as a portable device.

Key Features

- ✓ Drip-proof, durable and portable
- ✓ Accurate digital measurement of bottle top closure torque (sigma, mean and range)
- ✓ 200 date and time stamped reading memory
- ✓ Data can be downloaded to a PC or Printer
- ✓ Programmable torque threshold for fast and easy testing



Crane Electronics Ltd
The force in torque management

Lineside Controllers

TCI & TCI Multi

The TCI (Tool Control Interface) allows the user to connect a digital torque wrench to be used in assembly production. The WrenchStar Multi can be connected to the TCI at the push of a button.

The TCI allows easy management, set up and diagnostics of itself via Web Browsers and it can be used as a stand-alone and where Jobs can be selected and results sent to a PC or web page. The unit accepts Open Protocol commands via Ethernet to select a Job to use with the WrenchStar Multi.

The TCI has a 'Web Status' page that allows Ethernet properties, RF properties, logging of messages, and wrench status to be monitored. The web page mirrors the last torque and angle reading from the wrench, plus its torque status (LO, OK and HI). Built-in LED lights show the real-time status of the torque wrench connection on the unit.



Key Features

- ✓ Connect between 1 (TCI) and 5 (TCI Multi) torque wrenches at the push of a button
- ✓ Easy management, set up and diagnostics via web browsers
- ✓ Jobs can be selected and results sent to a PC
- ✓ Ethernet properties, RF properties, logging and wrench status can be monitored
- ✓ 'Web Status' page mirrors last torque and angle reading from the wrench plus its torque status
- ✓ LED lights show real-time status of all connections

Accessories

Joint Kits

The performance of an assembly tool is highly dependent on the conditions of the actual production joint on which it is used. Tooling engineers are well aware of the 'mean shift' term used to describe the different torque delivered by the same tool when applied to a 'Soft' or 'Hard' joint. It is therefore essential in testing and setting up tools off the production line to allow for the joint condition which the tool will experience on the job.

Crane's joint kits satisfy this requirement by using a bolt and suitably configured disc washers allowing free running of the bolt and a subsequent torque gradient to closely match the production Joint condition.

Two versions are available: female 'Transducer Top' joint kits are used in conjunction with female stationary transducers, while 'Table Top' joint kits are used with CheckStar rotary transducers. The latter are fixed to a workbench and are particularly suitable for off-line testing of impulse tools. Both versions incorporate a selection of disc washers and spacers that may be configured to simulate various joint conditions.



Crane Electronics Ltd
The force in torque management

Wrench ID Heads

Crane Electronics can also offer a number of interchangeable torque wrench heads for our range of torque wrenches. These are perfect for applications that require quick, efficient and repetitive head changes for wrench operation.

The torque wrench heads can be supplied as standalone heads or they can be supplied with an ID chip installed. This allows the heads to communicate with our series of torque wrenches.

The ID chip allows the wrench to automatically adjust its torque readings, accommodating for the size and length of the particular attached head, making it quick and easy to swap between Jobs and giving complete peace of mind for the customer.



WrenchLoader

The WrenchLoader from Crane works by simulating the conditions of a particular torque application, allowing the user to test torque wrenches by measuring the torque applied, via a transducer, allowing the wrench to be calibrated with precision accuracy and complete confidence.

The WrenchLoader allows for quick and simple calibration of digital torque wrenches and the easy-to-use system removes the risk of human error and inaccurate readings during the calibration process.

The flexible design of the WrenchLoader allows for the testing and calibrating of various torque wrench lengths and types.



Crane Electronics Ltd
The force in torque management

Service & Calibration

Service & Repair

As a specialist manufacturer of torque measuring equipment we take pride in maintaining and restoring our products after wear and tear in the industry. Our experienced and highly trained staff have a broad range of technical expertise and are able to offer a fast, efficient turnaround whether your product requires a general service, repair or both.

At both of our service and calibration labs in the UK and USA, we stock a wide range of spare parts and components to be able to deliver a rapid response to the requirements of our customers.

Key Features

- Full Service and Repair Facility
- Torque Calibration
- Angle Verification
- Technical Customer Support Team
- UKAS Accredited Calibration Laboratory
- ISO 17025 Accredited
- ISO 14001 Registered
- ISO 9001 Registered
- NIST (Nat. Institute of Standards & Technology) Accredited



Crane Electronics Ltd
The force in torque management

Calibration

Our mission is to offer a free of charge initial assessment, which is carried out upon receipt of equipment. We then supply a quote for the calibration of the equipment, plus any repairs if required. Our aim is to return the equipment electronically and mechanically as new. We also offer software upgrades on all equipment where applicable.

The importance of calibration for torque measurement equipment can never be underestimated.

Equipment, such as torque wrenches, transducers and data collectors, are used across a number of industries including the manufacture of automobiles and aircraft. Such industries place heavy importance on high quality production with safety and security of the end user being paramount.

Manufacturers must ensure that all tools used to tighten critical fasteners, and all torque measuring equipment used to validate these tools and joints, are accurate and providing the correct and safe level of torque tightening.

We are backed up by a range of high specification torque calibration equipment and instrumentation in our calibration lab. We also stock a large variety of spare parts and our experienced and highly trained staff are always on hand to provide a first-class service.

NEW! Angle certification now available

We are now proud to be able to offer rotary torque transducer and digital torque wrench angle certification, thanks to our new dedicated Angle Certification rigs.

We now have 2 rigs in action which can certify torque Wrenches up to 340Nm and torque transducers, up to 1400Nm. The process is quick and easy and is accurate to within 1% for each reading.



Industries

Automotive

Torque measurement and management tools are used across the Automotive industry, where the assurance of the correct level of tightening torque is mandatory for health & safety, legal compliance, providing a high quality guarantee and so on.

Crane supplies torque equipment across a number of high profile OEMs and Tier 1 & 2 Suppliers in the Automotive industry, covering applications in production, research & development, inspection, auditing and quality control.

Long-term partnerships with multi-national vehicle and component manufacturers testify to Crane's innovative approach in the industry, with the majority of the world's leading car manufacturers believing in our products.

Construction, Mining & Agriculture

All Construction, Mining and Quarrying equipment suppliers have a critical requirement for accurate torque management and measurement. Equipment failure onsite can result in down-time which proves extremely costly in an industry with such high demand and importance on delivery. Our torque tools and management systems are utilised in the Construction & Mining industry by manufacturers of heavy duty machinery.

Key components of this machinery, such as engines and moving parts on excavators, require precision levels of torque tightening on the critical joints and connections.

Crane Electronics' products can provide peace of mind for manufacturers and end users in this industry with our high quality torque management and measurement tools, ensuring safe and secure fastening of equipment and structures.

Aerospace

Torque measurement and management tools are used across the Aerospace industry where the assurance of the correct level of torque is vital for critical components and parts. As well as being mandatory for health & safety, legal compliance, a high-quality guarantee, etc.

To achieve the high quality and safety standards required, measurement, control and the recording of torque, angle and pulse during the assembly process is essential. Crane has many products that will meet this requirement as well as an innovative problem-solving approach.

Crane supplies equipment to a number of high profile companies in the Aerospace Industry covering applications within production, research & development, inspection & auditing departments, such as the auditing of assembly tools and the quality control of parts and components such as jet engines, fuel lines and much more.

Renewable Energy

Power generation, utilising both fossil fuels or nuclear power, are the current typical methods in the Energy industry today. However, as global reserves slowly become depleted, the influence and investment within renewable energy methods is increasing.

With new technologies evolving and becoming more widespread, the requirement for torque management and measurement is becoming increasingly evident. For example, with the growing popularity and ease of access to renewable wind energy, the production, installation and maintenance of wind turbines requires the correct torque levels within critical components.

This is vital as they will often have to operate in extremely hostile environments such as offshore and in regions that are exposed to harsh weather conditions.

Our Industrial Measurements (IM) brand also has a wide range of products and solutions for the Renewable Energy industry for accurate torque measurement within critical components, often moving parts and generators that require higher torque & industrial sized solutions.

Crane Electronics Ltd
The force in torque management

Marine & Offshore

Correct torque levels are vital during the manufacturing and auditing of ship and boat builds and across the Marine industry. Key components, which are likely to be tested by heavy use and severe weather conditions, need to be safe and secure meaning Joint and Fastener Torque levels must be completely accurate, reliable and traceable. Crane equipment can ensure this process is taken care of, giving peace of mind to our customers.

Similarly, in the Offshore industry, equipment also has to withstand harsh environments or must perform maintenance tasks quickly and accurately. Cranes torque measurement equipment and torque tool auditing and management systems are the perfect choice.

For the measurement and management of much larger torque levels up to 10 million Nm, our Industrial Measurements brand includes a wide range of products & solutions for the Marine & Offshore markets for industrial-sized applications.

Rail

Crane Electronics' torque measurement and management solutions are utilised across the Rail industry in a number of applications. We have supplied rail carriage manufacturers with a number of our torque tool auditing equipment, ensuring the correct and safe assembly of their carriages for both rail and subway applications.

In addition, manufacturers of key components such as braking systems and actuators have utilised our torque wrench & data collector pairing to ensure all component assemblies are secure and all of important production data is collected and stored for their records.

The requirement for Rail safety is just as paramount as in all other transport areas such as Automotive and Aerospace. Our torque tool testing and auditing solutions ensure that manufacturers, end-users and passengers have peace of mind that the fastening of all critical joints, parts and components are correct, recorded and traceable.

Crane Electronics Ltd
The force in torque management

Pharmaceutical, Food & Beverage and Bottling

Crane Electronics has a history of supplying torque management tools for various bottling and packaging applications in the pharmaceutical and food & beverage markets.

The proper and correct compression and sealing of pharmaceutical packaging for example, is a vital area of torque measurement and management that companies in this industry must comply to.

Our products can help accurately and efficiently measure the tightening of this packaging, such as ensuring the correct level of tension is in place on the caps placed on medicinal bottles: enough to keep potentially harmful medication away from children, for example, but not too much so that the elderly or frail who need the medicine cannot open them.

Our products help to assure safety of products, prevent leaks and also reduce the ergonomic issues associated with these products without compromising safety or quality.

Other Industries

Our torque measurement and management equipment is also utilised across a number of other industries and specialist applications. For example, our torque transducers, wrenches and data collectors are used in the manufacture of products ranging from white good and appliances, consumer electronics and even office chairs.

In any application where tightening of a fastener is required and traceability is key, Crane Electronics can offer our expertise to find a solution for you.



Crane Electronics Ltd
The force in torque management





Distributed by

Applifast.

We are committed.



Contact Applifast

251 Cree Crescent

Winnipeg, MB

Canada R3J 3X4

Tel: 204 837 8361 • 1 800 563 1293

Fax: 204 837 3520 • 1 800 974 1494

info@applifast.com



applifast.com