



# ARCONIC

Innovation, engineered.

## Instruction Manual

### 2025 series

#### Pneudraulic Installation Tools

*Patent Pending*



*Standard 2025 shown with Nose Assembly (not included)*

**Declaration of Conformity**  
2

**Safety Instructions**  
3

**Specifications**  
4-6

**Principle of Operation**  
7

**Preparation for Use**  
7

**Operating Instructions**  
8

**Maintenance**  
8

**Disassembly Instructions**  
9-10

**Assembly Instructions**  
11-12

**Fill and Bleed**  
13

**Measuring Tool Stroke**  
14

**Components Drawings**  
15-17

**Kits and Accessories**  
18

**Troubleshooting**  
18



**ARCONIC**

## EC Declaration of Conformity

**Manufacturer:**

Huck International, LLC, Industrial Products Group, 1 Corporate Drive, Kingston, NY, 12401, USA

**Description of Machinery:**

Models 202, 202#, ERT9, & ERT9# families of pneudraulic installation tools and specials based on their design (e.g. PR#####).

**Relevant provisions complied with:**

Council Directive related to Machinery (2006/42/EC)

British Standard related to hand held, non-electric power tools (ISO 11148-1:2011)

**European Representative:**

Rob Pattenden, Huck International, Ltd. Unit C Stafford Park 7, Telford Shropshire TF3 3BQ, England, United Kingdom

**Authorized Signature/date:**

I, the undersigned, do hereby declare that the equipment specified above conforms to the above Directive(s) and Standard(s).

Signature:

Full Name: Robert B. Wilcox

Position: Engineering Manager

Location: Huck International, LLC d/b/a Arconic Fastening Systems and Rings  
Kingston, New York, USA

Date: 01/11/2016 (November 1, 2016)



### Declared dual number noise emission values in accordance with ISO 4871

A weighted sound power level, LWA: **81** dB (reference 1 pW) Uncertainty, KWA: 3 dB

A weighted emission sound pressure level at the work station, LpA: **70** dB (reference 20 µPa) Uncertainty, KpA: 3 dB

C-weighted peak emission sound pressure level, LpC, peak: **115** dB (reference 20 µPa) Uncertainty, KpC: 3 dB

Values determined according to noise test code ISO 3744. The sum of a measured noise emission value and its associated uncertainty represents an upper boundary of the range of values which is likely to occur in measurements.

### Declared vibration emission values in accordance with EN 12096

Measured Vibrations emission value, a:	<b>.57 m/s<sup>2</sup></b>
Uncertainty, K:	<b>.28 m/s<sup>2</sup></b>

Values measured and determined according to ISO 28662-1, ISO 5349-2, and EN 1033

Test data to support the above information is on file at:  
Arconic Fastening Systems and Rings, Kingston Operations, Kingston, NY, USA.





# Safety Instructions

## GLOSSARY OF TERMS AND SYMBOLS:

 Product complies with requirements set forth by the relevant European directives.

 Read manual prior to using this equipment.

 Eye protection is required while using this equipment.

 Hearing protection is required while using this equipment.

Notes: are reminders of required procedures.

***Bold, Italic type, and underline:*** emphasize a specific instruction.

 **WARNINGS: Must be understood to avoid severe personal injury.**

 **CAUTIONS: Show conditions that will damage equipment or structure.**

### I. GENERAL SAFETY RULES:

1. A half hour long hands-on training session with qualified personnel is recommended before using Huck equipment.
2. Huck equipment must be maintained in a safe working condition at all times. Tools and hoses should be inspected at the beginning of each shift/day for damage or wear. Any repair should be done by a qualified repairman trained on Huck procedures.
3. For multiple hazards, read and understand the safety instructions before installing, operating, repairing, maintaining, changing accessories on, or working near the assembly power tool. Failure to do so can result in serious bodily injury.
4. Only qualified and trained operators should install, adjust or use the assembly power tool.
5. Do not modify this assembly power tool. This can reduce effectiveness of safety measures and increase operator risk.
6. Do not discard safety instructions; give them to the operator.
7. Do not use assembly power tool if it has been damaged.
8. Tools shall be inspected periodically to verify all ratings and markings required, and listed in the manual, are legibly marked on the tool. The employer/operator shall contact the manufacturer to obtain replacement marking labels when necessary. Refer to assembly drawing and parts list for replacement.
9. Tool is only to be used as stated in this manual. Any other use is prohibited.
10. Read MSDS Specifications before servicing the tool. MSDS specifications are available from the product manufacturer or your Huck representative.
11. Only genuine Huck parts shall be used for replacements or spares. Use of any other parts can result in tooling damage or personal injury.
12. Never remove any safety guards or pintail deflectors.
13. Never install a fastener in free air. Personal injury from fastener ejecting may occur.
14. Where applicable, always clear spent pintail out of nose assembly before installing the next fastener.
15. Check clearance between trigger and work piece to ensure there is no pinch point when tool is activated. Remote triggers are available for hydraulic tooling if pinch point is unavoidable.
16. Do not abuse tool by dropping or using it as a hammer. Never use hydraulic or air lines as a handle or to bend or pry the tool. Reasonable care of installation tools by operators is an important factor in maintaining tool efficiency, eliminating downtime, and preventing an accident which may cause severe personal injury.
17. Never place hands between nose assembly and work piece. Keep hands clear from front of tool.
18. Tools with ejector rods should never be cycled with out nose assembly installed.
19. When two piece lock bolts are being used always make sure the collar orientation is correct. See fastener data sheet for correct positioning.

### II. PROJECTILE HAZARDS:

1. Risk of whipping compressed air hose if tool is pneudraulic or pneumatic.
2. Disconnect the assembly power tool from energy source when changing inserted tools or accessories.
3. Be aware that failure of the workpiece, accessories, or the inserted tool itself can generate high velocity projectiles.
4. Always wear impact resistant eye protection during tool operation. The grade of protection required should be assessed for each use.
5. The risk of others should also be assessed at this time.
6. Ensure that the workpiece is securely fixed.
7. Check that the means of protection from ejection of fastener or pintail is in place and operative.

8. There is possibility of forcible ejection of pintails or spent mandrels from front of tool.

### III. OPERATING HAZARDS:

1. Use of tool can expose the operator's hands to hazards including: crushing, impacts, cuts, abrasions and heat. Wear suitable gloves to protect hands.
2. Operators and maintenance personnel shall be physically able to handle the bulk, weight and power of the tool.
3. Hold the tool correctly and be ready to counteract normal or sudden movements with both hands available.
4. Maintain a balanced body position and secure footing.
5. Release trigger or stop start device in case of interruption of energy supply.
6. Use only fluids and lubricants recommended by the manufacturer.
7. Avoid unsuitable postures, as it is likely for these not to allow counteracting of normal or unexpected tool movement.
8. If the assembly power tool is fixed to a suspension device, make sure that fixation is secure.
9. Beware of the risk of crushing or pinching if nose equipment is not fitted.

### IV. REPETITIVE MOTION HAZARDS:

1. When using assembly power tool, the operator can experience discomfort in the hands, arms, shoulders, neck or other parts of the body.
2. When using tool, the operator should adopt a comfortable posture while maintaining a secure footing and avoid awkward or off balanced postures.
3. The operator should change posture during extended tasks to help avoid discomfort and fatigue.
4. If the operator experiences symptoms such as persistent or recurring discomfort, pain, throbbing, aching, tingling, numbness, burning sensations or stiffness, these warnings should not be ignored. The operator should tell the employer and consult a qualified health professional.

### V. ACCESSORIES HAZARDS:

1. Disconnect tool from energy supply before changing inserted tool or accessory.
2. Use only sizes and types of accessories and consumables that are recommended. Do not use other types or sizes of accessories or consumables.

### VI. WORKPLACE HAZARDS:

1. Be aware of slippery surfaces caused by use of the tool and of trip hazards caused by the air line or hydraulic hose.
2. Proceed with caution while in unfamiliar surroundings; there could be hidden hazards such as electricity or other utility lines.
3. The assembly power tool is not intended for use in potentially explosive environments.
4. Tool is not insulated against contact with electrical power.
5. Ensure there are no electrical cables, gas pipes, etc., which can cause a hazard if damaged by use of the tool.

### VII. NOISE HAZARDS:

1. Exposure to high noise levels can cause permanent, disabling hearing loss and other problems such as tinnitus, therefore risk assessment and the implementation of proper controls is essential.
2. Appropriate controls to reduce the risk may include actions such as damping materials to prevent workpiece from 'ringing'.
3. Use hearing protection in accordance with employer's instructions and as required by occupational health and safety regulations.
4. Operate and maintain tool as recommended in the instruction handbook to prevent an unnecessary increase in the noise level.
5. Select, maintain and replace the consumable / inserted tool as recommended to prevent an unnecessary increase in noise.
6. If the power tool has a silencer, always ensure that it is in place and in good working order when the tool is being operated.

### VIII. VIBRATION HAZARDS:

1. Exposure to vibration can cause disabling damage to the nerves and blood supply to the hands and arms.
2. Wear warm clothing when working in cold conditions and keep hands warm and dry.
3. If numbness, tingling, pain or whitening of the skin in the fingers or hands, stop using the tool, tell your employer and consult a physician.
4. Support the weight of the tool in a stand, tensioner or balancer in order to have a lighter grip on the tool.

### IX. PNEUMATIC / PNEUDRAULIC TOOL SAFETY INSTRUCTIONS:

1. Air under pressure can cause severe injury.
2. Always shut off air supply, drain hose of air pressure and disconnect tool from air supply when not in use, before changing accessories or when making repairs.
3. Never direct air at yourself or anyone else.
4. Whipping hoses can cause severe injury, always check for damaged or loose hoses and fittings.
5. Cold air should be directed away from hands.
6. Whenever universal twist couplings (claw couplings) are used, lock pins shall be installed and whip-check safety cables shall be used to safeguard against possible hose to hose or hose to tool connection failure.
7. Do not exceed maximum air pressure stated on tool.
8. Never carry an air tool by the hose.



## Specifications

### Models 2025, 2025L, 2025S & 2025SL

**STROKE:**

0.675 in. (1.715 cm)

**WEIGHT:**

2025 & 2025L: 5 lbs 12 oz (2.61 kg)  
2025S & 2025SL: 7 lbs 4 oz (3.29 kg)

**MAX AIR PRESSURE:**

90 psi (6.2 bar)

**MAX FLOW RATE:**

8.5 scfm (241 l/m)

**POWER SOURCE:**

90 psi (6.2 bar) MAX shop air

**MAX OPERATING TEMP:**

125° F (51.7° C)

**PULL CAPACITY:**

5290 lbs @ 90 psi (23.531 kN @ 6.2 bar)

**SPEED / CYCLES:**

30 per minute

**HYDRAULIC FLUID:** Hydraulic fluid shall meet DEXRON III, DEXRON VI, MERCON, Allison C-4 or equivalent ATF specifications. Fire-resistant fluid may be used if it is an ester-based fluid such as Quintolubric HFD or equivalent. Water-based fluid shall NOT be used as serious damage to equipment will occur.

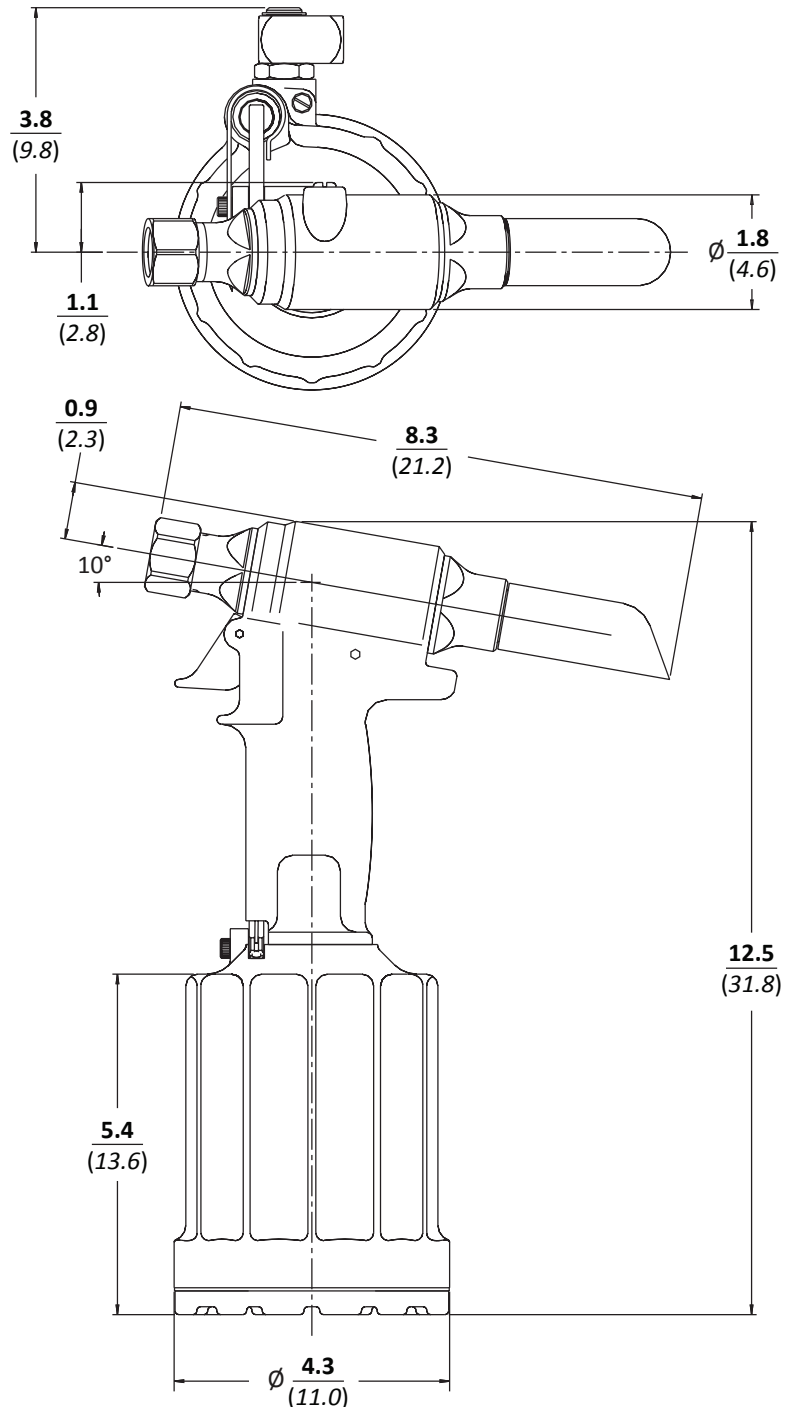



## Specifications

### Models 2025V & 2025LV

**STROKE:**

0.675 in. (1.715 cm)

**WEIGHT:**

5 lbs 12 oz (2.61 kg)

**MAX AIR PRESSURE:**

90 psi (6.2 bar)

**MAX FLOW RATE:**

8.5 scfm (241 l/m)

**POWER SOURCE:**

90 psi (6.2 bar) MAX shop air

**MAX OPERATING TEMP:**

125° F (51.7° C)

**PULL CAPACITY:**

5290 lbs @ 90 psi (23.531 kN @ 6.2 bar)

**SPEED / CYCLES:**

30 per minute

**HYDRAULIC FLUID:** Hydraulic fluid shall meet DEXRON III, DEXRON VI, MERCON, Allison C-4 or equivalent ATF specifications. Fire-resistant fluid may be used if it is an ester-based fluid such as Quintolubric HFD or equivalent. Water-based fluid shall NOT be used as serious damage to equipment will occur.

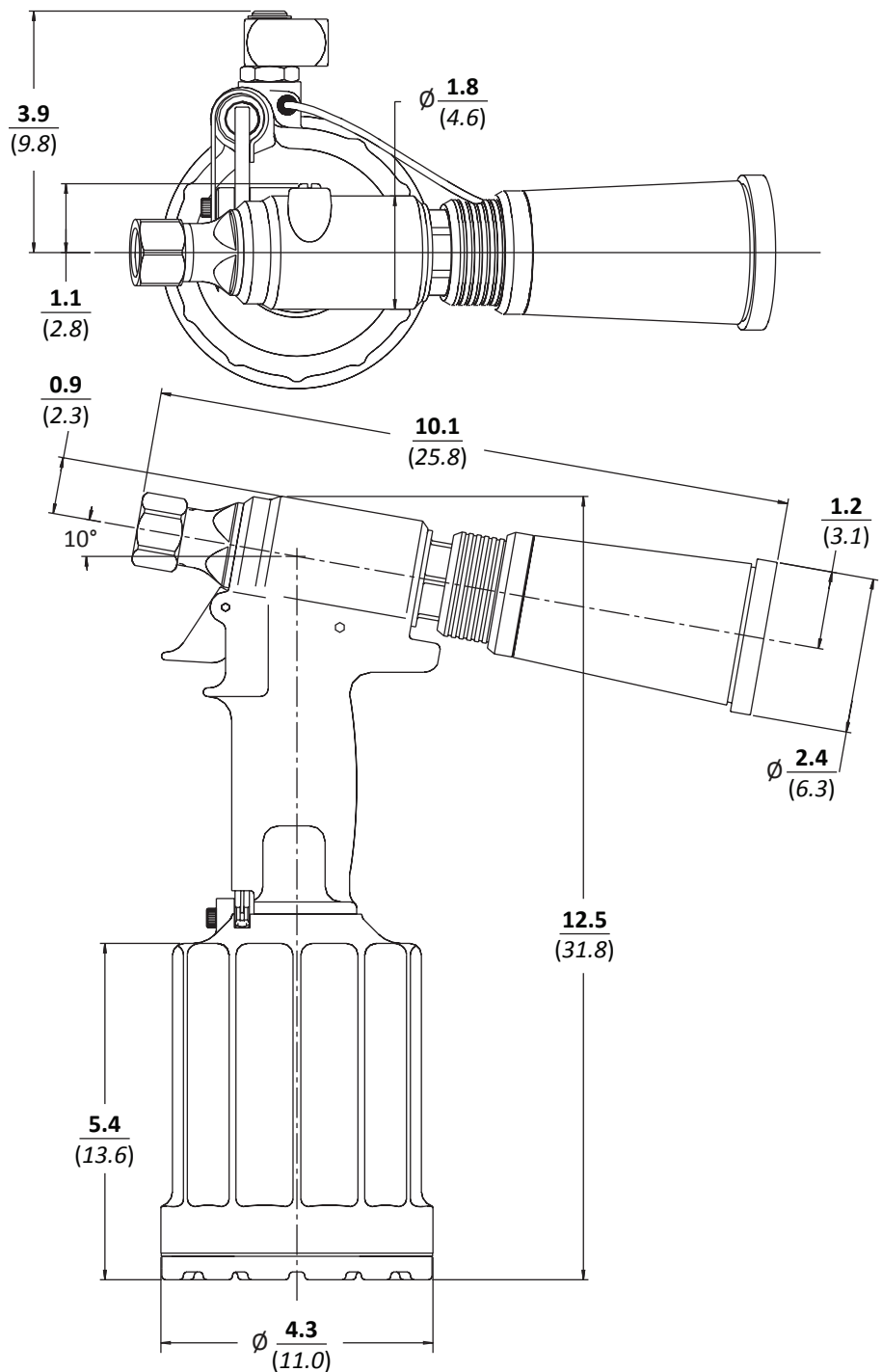



## Specifications

### Models 2025B & 2025LB

**STROKE:**

0.675 in. (1.715 cm)

**WEIGHT:**

5 lbs 12 oz (2.61 kg)

**MAX AIR PRESSURE:**

90 psi (6.2 bar)

**MAX FLOW RATE:**

8.5 scfm (241 l/m)

**POWER SOURCE:**

90 psi (6.2 bar) MAX shop air

**MAX OPERATING TEMP:**

125° F (51.7° C)

**PULL CAPACITY:**

5290 lbs @ 90 psi (23.531 kN @ 6.2 bar)

**SPEED / CYCLES:**

30 per minute

**HYDRAULIC FLUID:** Hydraulic fluid shall meet DEXRON III, DEXRON VI, MERCON, Allison C-4 or equivalent ATF specifications. Fire-resistant fluid may be used if it is an ester-based fluid such as Quintolubric HFD or equivalent. Water-based fluid shall NOT be used as serious damage to equipment will occur.

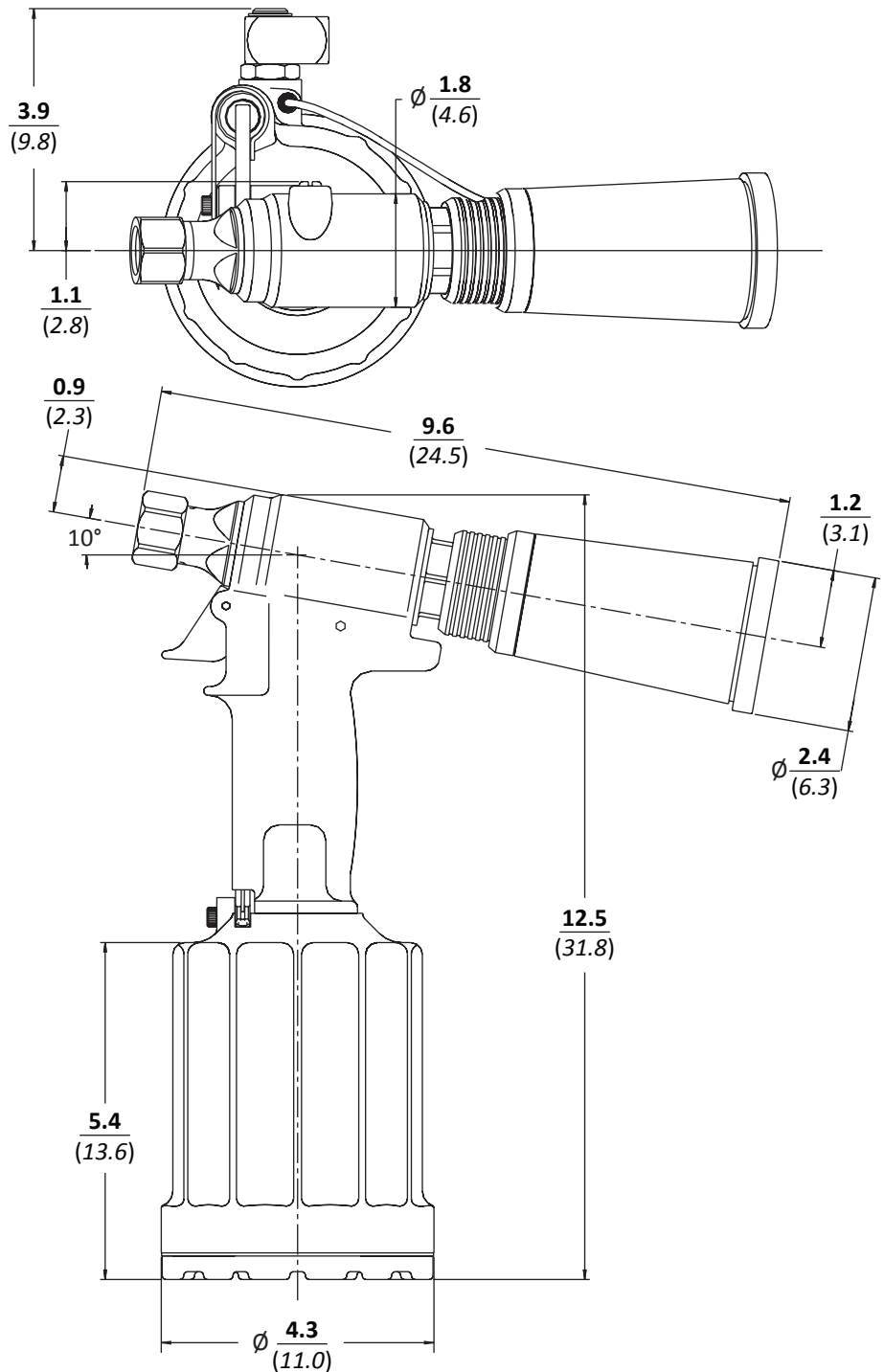



## Principle of Operation

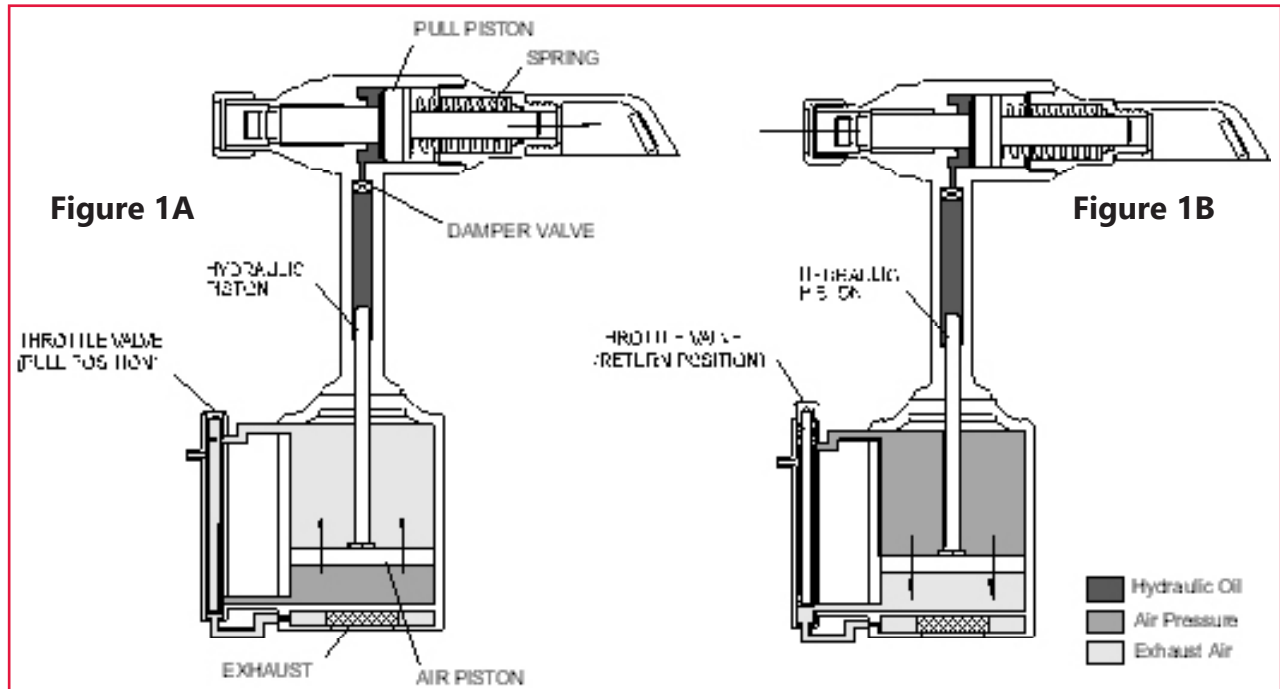

When the trigger is pressed, the throttle valve moves downward to the PULL position, and pressurized air is directed to the bottom of the air piston, causing it to move upward (Figure 1A). The air above the air piston is exhausted and directed through the center of the throttle valve and out the bottom of the tool.

As the hydraulic rod moves upward, a column of fluid is forced into head, which moves the pull piston backward. The attached nose assembly moves with the pull piston to start fastener installation.

When fastener installation is completed, the trigger is released. Air pressure, with the assistance of a spring, sends the throttle valve to the up (RETURN) position. Pressurized air is re-directed to the top of the air piston (Figure 1B), causing the air piston and hydraulic rod to move downward.

The air from below the piston is exhausted through the bottom of the tool, and springs force the pull piston to return to its home position. The damper valve (Figure 1A) impedes oil flow at pin break to prevent “tool kick.”

## Preparation for Use

The 2025 series of tools ship with a plug in the air inlet connector. The connector has 1/4-18 female pipe threads to accept the air hose fitting. Huck recommends quick-disconnect fittings and a 1/4" inside-diameter air hose. The air supply should be equipped with a filter-regulator-lubricator unit, and access to a 90 psi (6.2 bar) air supply capable of 20 ft<sup>3</sup>/s (.57 m<sup>3</sup>/s).

**NOTE: Air quick-disconnect fittings and air hoses are not available from Huck.**

1. Remove the shipping plug from air inlet connector and add a few drops of an approved hydraulic fluid.
2. Screw the quick-disconnect fitting into the air inlet connector.



**CAUTION: Do not use Teflon® tape on pipe threads. Tape could shred, resulting in malfunctions. Threadmate® is available in a 4oz. tube from Huck (P/N 508517).**

3. Set the air pressure on the regulator to 90–100 psi (6.2–6.9 bar), and connect the air hose to the tool.
4. Press and release the trigger a few times to cycle the tool. Disconnect the air hose from the tool, and

remove the retaining nut.

5. Select the proper nose assembly for the fastener being installed.
6. Screw the collet assembly (including the lock collar and shim if applicable) onto the spindle and tighten with a wrench.
7. Slide the anvil over the collet assembly and into the counterbore. Slide the retaining nut over the anvil, and screw the nut onto the head.
8. Connect the air hose to the tool and install fasteners in a test plate of proper thickness with proper size holes. Inspect the fasteners.

If fasteners do not pass inspection, see TROUBLESHOOTING to investigate possible causes.

**NOTE: On older nose assemblies with lock collars, use Loctite® 243™ on collet threads, because the 2025 pull piston does not have staking holes. Refer to the nose assembly drawings that shipped with nose assemblies.**



## Operating Instructions

### BLIND FASTENER INSTALLATION

The fastener can be placed in either the work hole or the end of the nose assembly. For both methods, the tool and nose assembly must be held against the work and at a right angle (90-degrees) to it. Press and hold the trigger until the fastener is installed and the pintail breaks. Release the trigger.

### MAGNA-GRIP® FASTENER INSTALLATION

Place the pin in the work-hole and place the collar over the pin. See WARNINGS. (If the collar has only one tapered end, that end must be out toward tool.) Hold the pin in the hole. Push the nose assembly onto the pin protruding from the collar until the anvil touches the collar. Press and hold the trigger until the collar is swaged and the pintail breaks. Release the trigger.



**CAUTION:** Remove excess gap from between sheets so that enough of the pintail protrudes from the collar that all of the jaw teeth can grip the pintail grooves. Jaws that are not fully gripping pintail grooves will be stripped or broken.



### WARNINGS:

**Inspect tools for damage and wear before using. Do not use if damaged or worn; serious personal injury may occur.**

**Pulling a pin without a collar, or with collar chamfer against workpiece, may result in the pin becoming a high-speed projectile when the pin grooves are stripped or the pintail breaks off. Serious personal injury may occur to anyone in the pin's "flight path." This includes pins that ricochet.**

**Broken pintails eject from the deflector with speed and force. Be sure the pintail deflector is directed safely away from all personnel. Ejecting pintails striking anyone may cause serious personal injury. Always use pintail bottles with models 2025B and 2025V. Replace damaged pintail deflectors and bottles to avoid serious personal injury.**

## Maintenance

### GENERAL

The operating efficiency of your tool is directly related to the performance of the entire system. Regular inspection and the immediate correction of minor problems will keep the tool operating efficiently, and prevent downtime. A schedule of "preventive" maintenance of the tool, nose assembly, hoses, trigger and control cord, and POWERIG will ensure your tool's proper operation and extend its life. **NOTE: Huck tools should be serviced only by personnel who are thoroughly familiar with their operation.**

- Service the tool in a clean, well-lighted area. Take special care to prevent contamination of pneumatic and hydraulic systems.
- Have available all necessary hand tools—standard and special.
- Carefully handle all parts. Before reassembly, examine them for damage and wear. Always replace seals when a tool is disassembled.
- Disassemble and assemble tool components in a straight line. Do NOT bend, cock, twist, or apply undue force. Follow the DISASSEMBLY and ASSEMBLY procedures in this manual.
- Have Service Parts Kit 2025KIT available when servicing the tool; it includes important consumable parts. Other components, as experience dictates, should also be available.

### DAILY

- If a Filter-Regulator-Lubricator unit is not being used, uncouple the air disconnects and add a few drops of hydraulic fluid or a light-weight oil to the air inlet of the tool.

**NOTE: If the tool is in continuous use, add a few drops of oil in every 2–3 hours.**

- Before connecting an air hose to the tool, bleed the air lines to clear dirt or water.
- Check all hoses and couplings for damage and air leaks; tighten or replace if necessary.
- Check the tool for damage and air or hydraulic leaks; tighten, repair, or replace if necessary.
- Check the nose assembly for tightness and damage; tighten or replace if necessary.
- Periodically, check the tool stroke. If the stroke is short, add fluid. For more information, see MEASURING TOOL STROKE.

### WEEKLY

- Disassemble, clean, and reassemble nose assembly in accordance with applicable instructions.
- Check the tool and all connecting parts for damage and fluid/air leaks; tighten or replace if necessary.

**Where the following trade names are used in this manual, please note:**

**DEXRON** is a registered trademark of General Motors Corporation.

**GLYD Ring** is a registered trademark of Trelleborg Sealing Solutions Germany GmbH

**Loctite** is a registered trademark of Henkel Corporation, U.S.A.

**LUBRIPLATE** is a registered trademark of Fiske Brothers Refining Co.

**MERCON** is a registered trademark of Ford Motor Corp.

**MOLYKOTE** is a registered trademark of Dow Corning Corporation

**Never-Seez** is a registered trademark of Bostik, Inc.

**Quintolubric** is a registered trademark of Quaker Chemical Corp.

**Slic-tite** is a registered trademark of LA-CO Industries, Inc.

**Spirolox** is a registered trademark of Smalley Steel Ring Company

**Teflon** is a registered trademark of Chemours Company FC.

**Threadmate** is a registered trademark of Parker Intangibles LLC.

**TRUARC** is a trademark of TRUARC Co. LLC.

**Vibra-Tite** is a registered trademark of ND Industries, Inc. USA.





## Disassembly Instructions



**WARNING: Disconnect the air hose from the tool before performing any maintenance. Serious personal injury could result if the air hose is connected.**

This procedure is for complete disassembly of the tool. Disassemble only those components necessary to replace damaged O-rings, Quad-rings, Back-up rings, and worn or damaged components. For component identification, see Figures 2, 14, 14A & 15.



**CAUTION: Always use a soft-jaw vise to avoid damaging the tool.**

### GENERAL

NOTE: **For models 2025S & 2025SL, follow the procedures for models 2025 & 2025L.**

1. Disconnect the tool from the air source.
2. Unscrew the retaining nut, and remove the nose assembly.
3. Unscrew the bleed plug from top of the handle/head. Turn over the tool and drain the fluid into a container. (Figures 10 & 14A)
4. Models 2025 & 2025L: Pull the pintail deflector off the end cap.

Models 2025B & 2025LB: Reach in the window of the pintail bottle and remove the retaining ring and washer; then remove the pintail bottle and adapter. (Figures 14A & 15)

Models 2025V & 2025LV: See PINTAIL BOTTLE/VACUUM SYSTEM.

5. Remove the throttle arm pivot screw and the lever guard. Lift out the throttle arm, and disconnect ball end of the cable assembly from it.
6. Secure the tool in a vise, upside-down. (Figure 2) Remove the button head screws with 1/8" hex key. Remove the end cap and gasket, and remove the muffler from the end cap. Remove the spring from the throttle valve. (Figure 14)

7. Tap down the cylinder head with a soft mallet (to take pressure off the ring), and remove the retaining ring. (Figure 2)
8. Screw the button head screws into the cylinder head, and carefully pry on the screws to remove the head. Remove the O-ring.
9. Pull on lock nut with vise-grips to remove air piston from cylinder. Remove piston Quad-ring.



**CAUTION: DO NOT scratch the piston rod or cylinder when removing them.**

10. Remove the bumper from the gland assembly. Unscrew gland assembly with 1-3/8" socket wrench and extension.
11. Remove the Spirolox® Retaining Ring from the gland, and then pull out the spacer and Polyseal. Remove the O-rings, Quad-ring, and Back-up ring. (Figure 14)
12. Lift the cylinder from the handle/head.
13. Turn over the tool and drain the fluid into a container; discard the fluid.
14. Remove the throttle valve from the air cylinder, and remove the O-rings. (Figure 14)

**Figure 2**

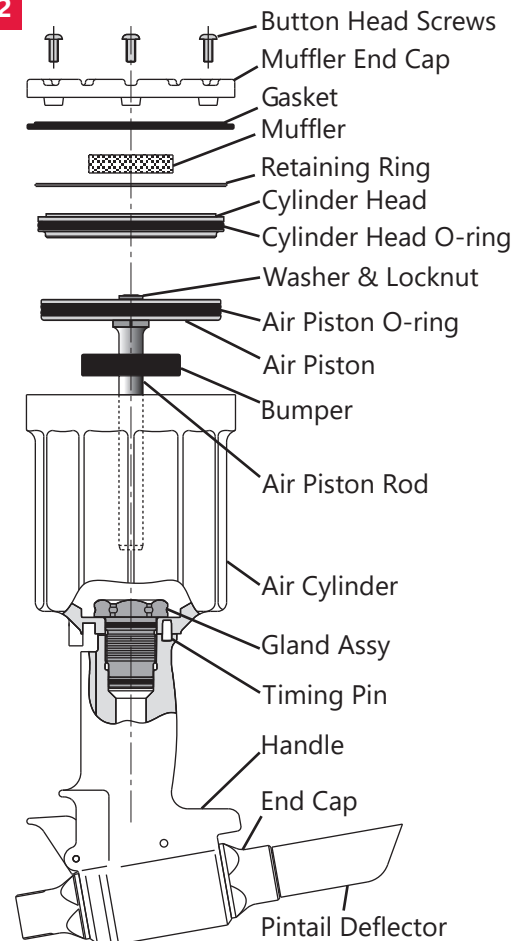



## Disassembly Instructions (continued)

### HEAD/HANDLE

This procedure is applicable to models 2025 and 2025L. For component identification, see Figures 3, 4, & 14A.

**NOTE: For 2025V, see PINTAIL BOTTLE/VACUUM SYSTEM.**

1. Unscrew end cap; remove spring, spacer, and wiper seal.
2. Thread the Polyseal Insertion Tool into the rear of the handle/head. (Figure 3)
3. Slide the spacer onto the piston; then thread the Piston Assembly Tool onto the piston (Figure 3).
4. Push the piston and front gland assemblies out the back of the handle/head. Allow clearance, with stand-off, as the piston leaves the tool. (Figure 4)
5. Unscrew the Piston Assembly Tool and remove Spacer from the piston. Re-thread the Piston Assembly Tool onto the piston, then slide the front gland assembly off the piston. (Figure 4)
6. Remove the Piston Assembly Tool from the piston, and remove the Polyseal Insertion Tool from the rear of the head/handle.
7. Remove the retaining ring, washer, and Polyseal from the piston. **NOTE: Inspect the hydraulic piston for wear, scoring, and damage; replace if necessary.**

8. Unscrew the adapter. (Figure 14A) Inspect all seals and parts.
9. If trigger cable assembly is damaged, remove it by driving the pin out with punch. Remove dowel pin to disconnect cable from trigger.

### PINTAIL BOTTLE/VACUUM SYSTEM

This procedure is applicable to models 2025V and 2025LV only; it should be used in conjunction with the previous sections, GENERAL and HEAD/HANDLE. For component identification, see Figures 5, 6, & 15.

1. Reach through the window of pintail bottle and remove the retaining ring and washer. (Figure 5)
2. Remove the pintail bottle, and then disconnect the tube from the connector. (Figure 15)
3. Remove the adapter and Tubing & Slide Assembly.
4. Remove the end cap and spring. (Figure 6)
5. Remove the spacer and O-ring from the spring side of the end cap.
6. Remove the retaining ring, wiper housing, wiper seal, washer and O-ring from the bottle side of the end cap.
7. Remove the O-rings from inside the adapter and Tubing & Slide Assembly. (Figure 15)

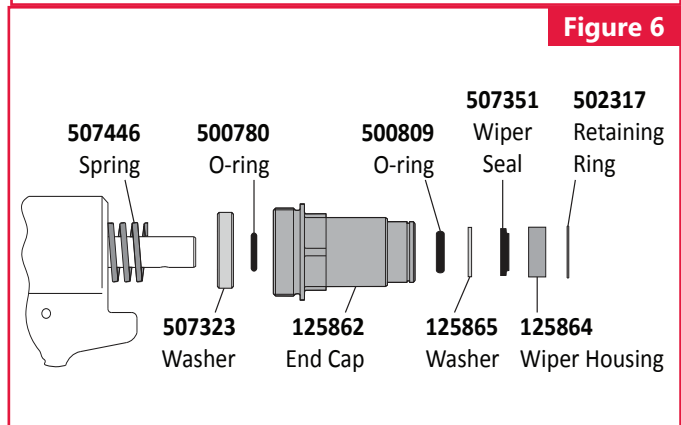
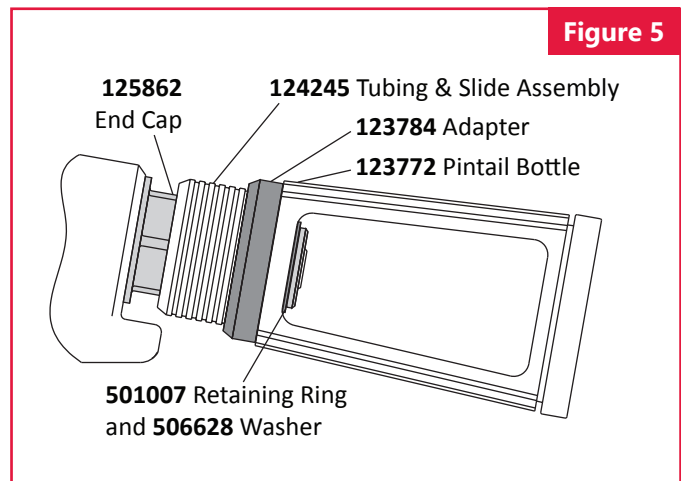
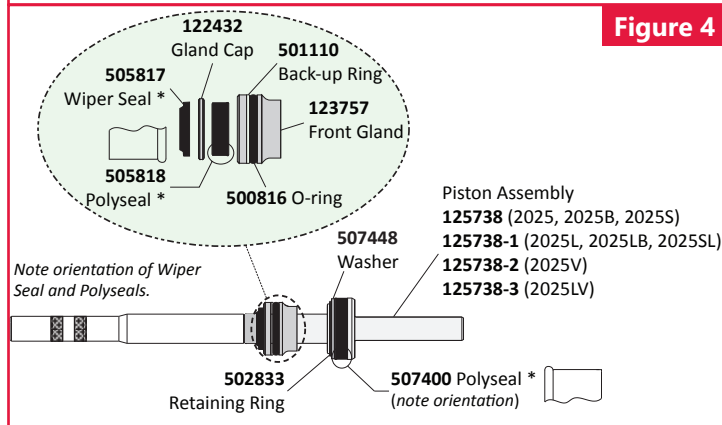
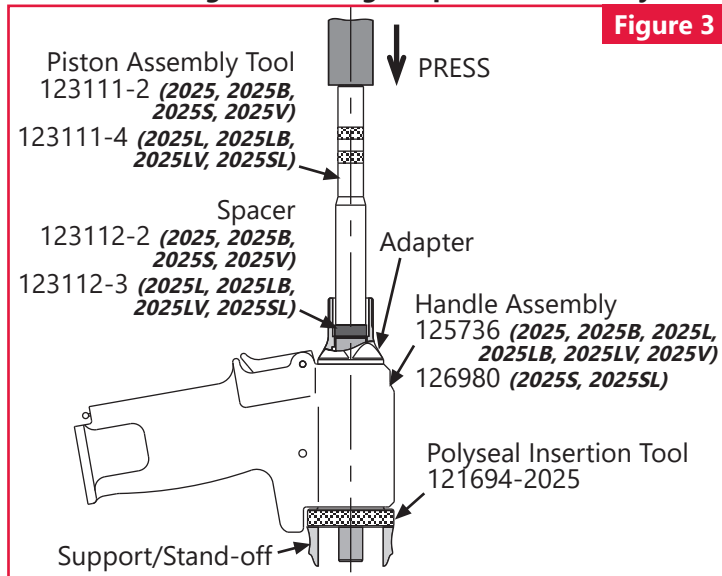



## Assembly Instructions

### HEAD/HANDLE

This procedure is for the assembly of the head/handle of models 2025, 2025B, 2025L, and 2025LB. For models 2025S and 2025SL, follow the procedures for models 2025 and 2025L. For component identification, see Figures 7, 8, & 14A.

### PRIOR TO RE-ASSEMBLING THE TOOL:

Clean components with mineral spirits or a similar solvent. Inspect for wear/damage and replace as necessary.

- Replace all seals of disassembled components.
- Use the O-rings, Quad-rings, and Back-up rings from Huck Service Parts Kits (P/N 2025KIT or 2025VKIT).

When assembling the tool, take care not to damage O-rings, Quad-rings, Back-up rings.

Smear LUBRIPLATE® 130-AA (Huck P/N 502723) or Parker O-Lube® (Huck P/N 505476) on O-rings, Quad-rings, Back-up rings, and mating parts to ease assembly.

### TO RE-ASSEMBLE THE TOOL:

If removed, position cable assembly in the trigger slot and slide dowel pin through holes in the trigger and the cable assembly. Position the assembled trigger in the handle and drive the pin through the holes in the handle and trigger. (Figure 14A)

1. Screw nose adapter into head and tighten.
2. Thread the Polyseal Insertion Tool (P/N 121694-2025) into the head.
3. Assemble the piston, Polyseal, and retaining ring. (Note the orientation of the Polyseal in Figure 7.)
4. Assemble the front gland, O-ring, Back-up ring, Polyseal, and gland cap. (Note the orientation of the Polyseal in Figure 7.)
5. Thread the Piston Assembly Tool (P/Ns in Figure 8) onto the piston. Slide the complete gland assembly and wiper seal onto piston.
6. Use a press to gently install the assembled components through the rear of the tool. (Figure 8)

7. Remove the Piston Assembly Tool and Polyseal Insertion Tool.
8. Install rear wiper seal into end cap. (Figure 14A)
9. Slide spacer and spring into end cap, and then thread end cap assembly into rear of head.

**NOTE: For 2025V, see PINTAIL BOTTLE/VACUUM SYSTEM on the next page.**

### GENERAL

For component identification, see Figures 2, 5, 7, 14A, & 15.

1. Secure the head/handle upside-down in a soft-jaw vise. (Figure 2) Place the inverted cylinder assembly on the base of the handle. (The timing pin maintains orientation.)
2. Assemble the gland assembly with new seals. (Note the orientation of the Polyseal in Figure 7.) Apply Anti-Seize Compound (P/N 508183) to the threads of the gland assembly. Screw the gland assembly into the head/handle and torque it to 36–66 ft.-lbs. using a 1-3/8" socket wrench.
3. Push bumper firmly over gland.  
**NOTE: The side of the bumper with two slots must face the bottom of the tool.**
4. Install the Quad-ring onto the air piston.
5. Lubricate the piston rod. Press the assembled air piston/rod into the cylinder just enough to allow installation of the cylinder head.
6. Assemble O-ring onto the cylinder head and then push the cylinder head squarely into the cylinder, taking care not to damage O-ring. Install retaining ring; align the screw holes with the muffler end cap.
7. Position the muffler in center of cylinder head. Position the gasket on cylinder. (Figure 2) Note the direction of the lip in Figure 7. *continued*

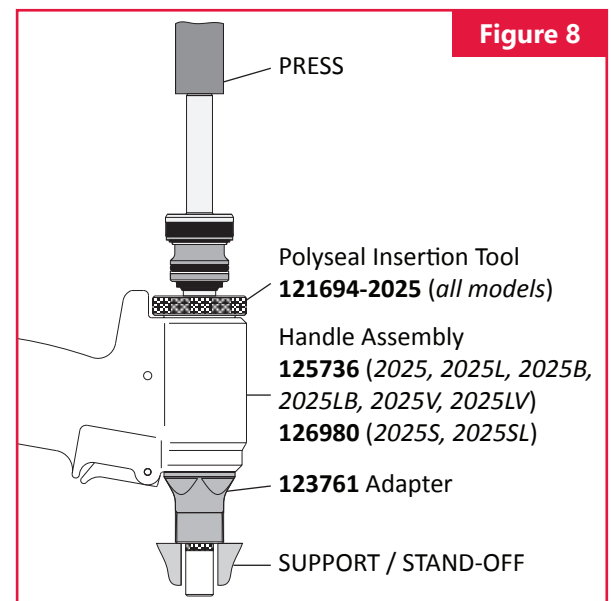
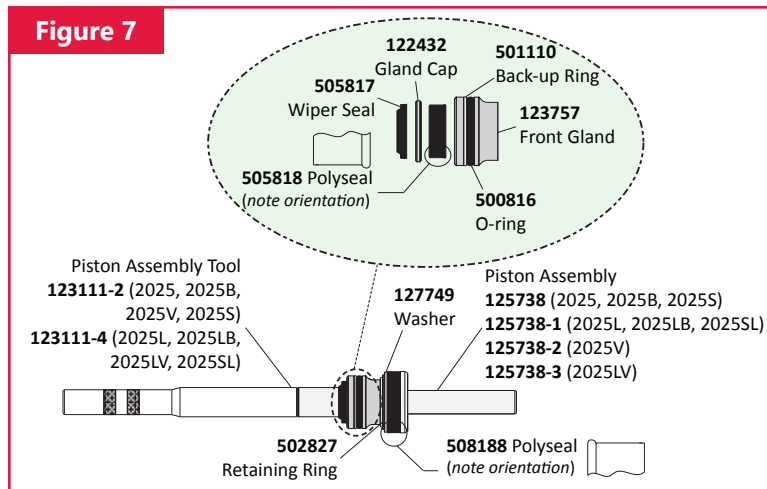



## Assembly Instructions (continued)

8. Carefully position the bottom plate on cylinder.  
Make sure that the muffler is properly positioned in the recess of the bottom plate. (Figures 2 & 14A)
9. Secure the bottom plate with the three button head screws using a 1/8" hex key. (Figure 2)
10. Assemble O-rings on throttle valve. (Figure 14)
11. Place the tool upright on a level surface. Drop the spring into the throttle valve bore in the cylinder, and push the throttle valve into the cylinder.
12. Place the ball end of the throttle cable into the end of the throttle arm, then slide the throttle arm into the slot on the cylinder. (Figure 14)
13. Snap the lever guard in place, and install the pivot screw in the cylinder to retain the throttle arm.
14. Models 2025 & 2025L: Push the pintail deflector onto the end cap.  
Models 2025B & 2025LB: Position the adapter and pintail bottle on the end cap. Reach in the window of the pintail bottle and install the retaining ring and washer. (Figure 15)

The tool is now assembled and must be filled with hydraulic fluid prior to use. See FILL AND BLEED.

### PINTAIL BOTTLE/VACUUM SYSTEM

This procedure is applicable to models 2025V and 2025LV only; it should be used in conjunction with the previous sections, GENERAL and HEAD/HANDLE. For component identification, see Figures 5, 6, & 15.

1. Assemble adapter and tube/slide assembly and new O-rings.
2. From bottle side of end cap install O-ring, washer, wiper seal, wiper housing and retaining ring as shown in Figure 6.
3. From spring side of end cap install O-ring, spacer, and spring. (Figure 6) Screw the entire assembly into the head; tighten.
4. Assemble the tube/slide assembly and O-rings; slide the complete assembly onto the end cap, and push tube into the connector. (Figure 15)
5. Position the adapter and pintail bottle on the end cap (Figures 5 & 15)
6. Reach through the window of the pintail bottle and install the washer and retaining ring as shown in Figure 5.



## Fill and Bleed

This section documents the “bleed-&-fill” procedure. For component identification, see Figures 9, 10, & 11.

### REQUIRED EQUIPMENT

- Automatic Transmission Fluid (ATF) DEXRON III or equivalent (Refer to SPECIFICATIONS for more information.)



**WARNING:** Avoid contact with hydraulic fluid. Hydraulic fluid must be disposed of in accordance with local regulations. See MSDS for hydraulic fluid shipped with tool.

- Shop air-line with 90 psi (6.2 bar) max.
- Air regulator
- Fill Bottle Assembly (P/N 120337, supplied with tool)
- Large flat-blade screwdriver
- Stall Nut (P/N 124090 or 125340, optional)
- Nose assembly
- Fasteners (optional)

### PREPARATION

- Install air regulator in the air-line and set the pressure to 20–40 psi (1.4–2.8 bar).
- Add an approved hydraulic fluid to the fill point of the Fill Bottle.

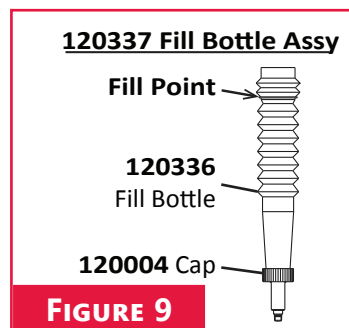

**FIGURE 9**

### TO FILL AND BLEED THE TOOL:

- Lay the tool on its side with the fill port facing up, and remove the bleed plug from the fill port.



**CAUTION:** All fluid must be purged from the tool before refilling. The tool stroke will be diminished if the fluid is aerated.

For optimal performance, refill with a fluid that is recommended in [SPECIFICATIONS](#).

- Connect the tool to shop air-line. If fluid is present, hold the tool over a suitable container with fill port facing into container. Cycle the tool several times to drain old fluid, air, and foam. (Figure 10)
- Screw the fill bottle into the fill port.



**WARNING:** Air pressure must be set at 20–40 psi (1.4–2.8 bar) to prevent possible injury from high-pressure spray.

If the bleed plug is removed, the Fill Bottle must be in place before cycling the tool.

- Stand the tool upright on a bench. Trigger the tool slowly (20–30 cycles), and bend the fill bottle at a right-angle to the tool. (Figure 11)

**FIGURE 10**

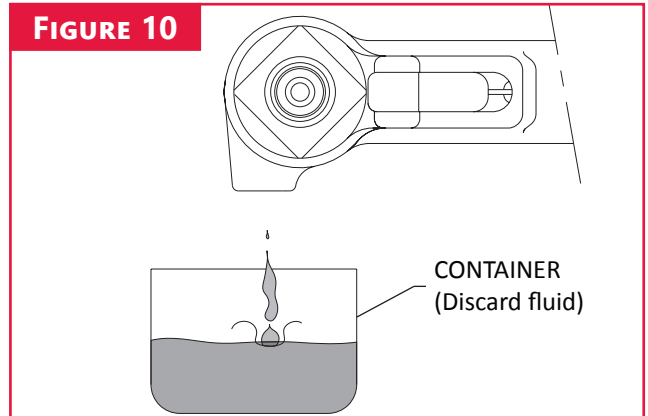

**FIGURE 11**

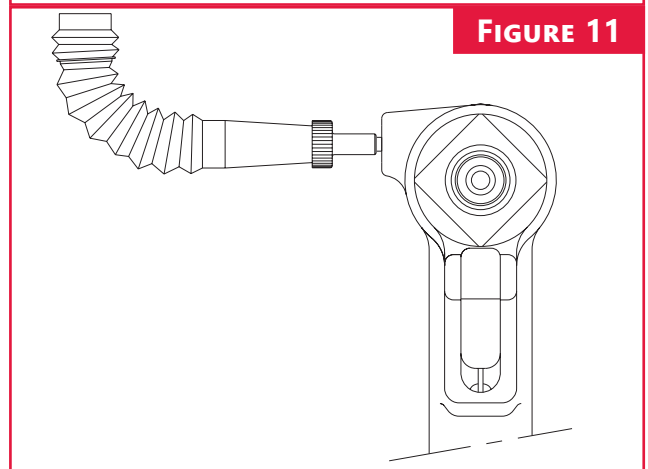

When air bubbles stop accumulating at top of the bottle, stop cycling the tool. When the trigger is released, the pull piston returns to the idle position (full-forward).

- Disconnect the tool from the air-line.
- Lay the tool on its side and remove the fill bottle. Top off the fluid in the fill port, and install and tighten the bleed plug.
- Connect the air-line to the tool and measure the stroke as described in [MEASURING TOOL STROKE](#). If the stroke is less than specified, remove the bleed plug and add fluid. Re-insert the bleed plug and recheck the stroke.
- Increase the air pressure to specifications. Install two fasteners to check the function and installation in a single stroke, or cycle the tool with a stall nut fully threaded onto the piston to load up the tool. Measure the stroke again. Remove the plug and add fluid. Re-insert the plug and cycle and measure again. Repeat this process until the stroke meets the minimum requirements.

## Measuring Tool Stroke

Figure 12

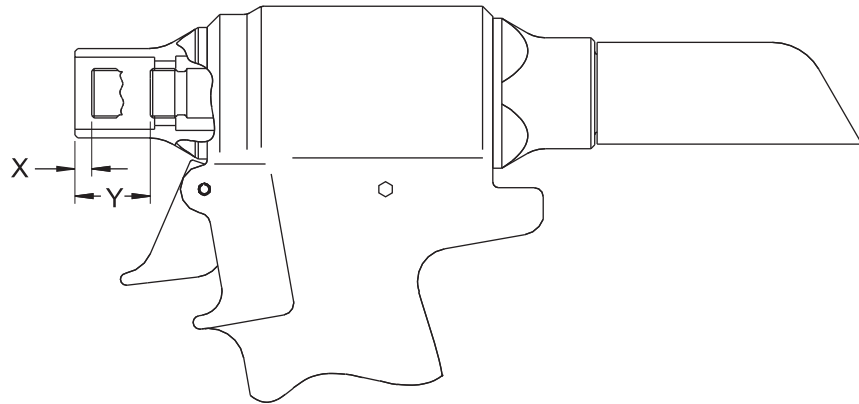

2025, 2025B, 2025S & 2025V

1. Cycle the piston all the way forward and measure X.
2. Cycle and hold the piston back and measure Y.

Stroke = Y-X

Figure 13

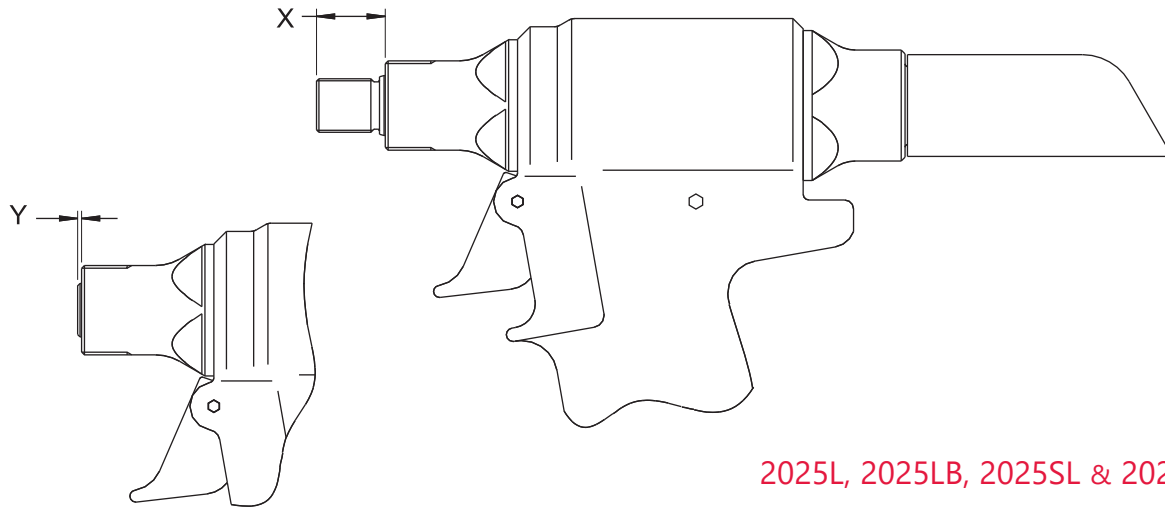

2025L, 2025LB, 2025SL & 2025LV

1. Cycle the piston all the way forward and measure X.
2. Cycle and hold the piston back and measure Y.

Stroke = X-Y



# Tool Base (all models)

**Figure 14**

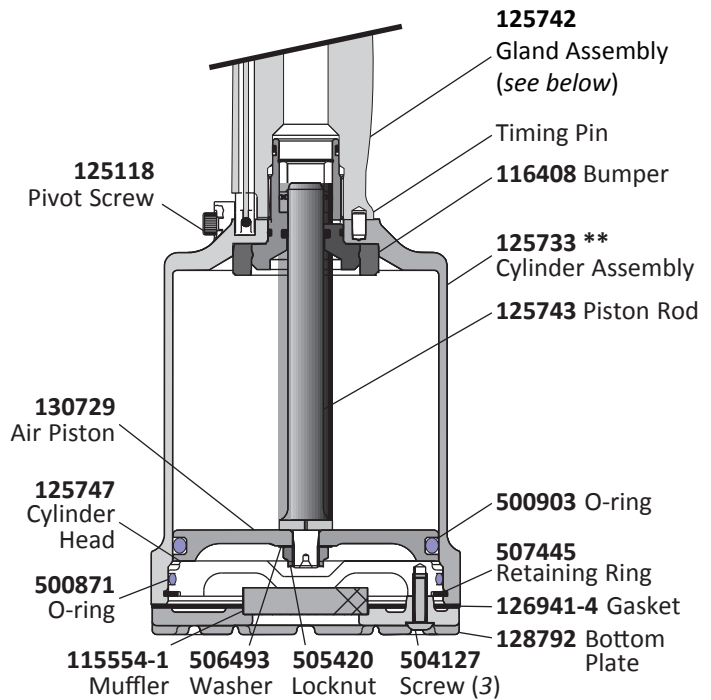
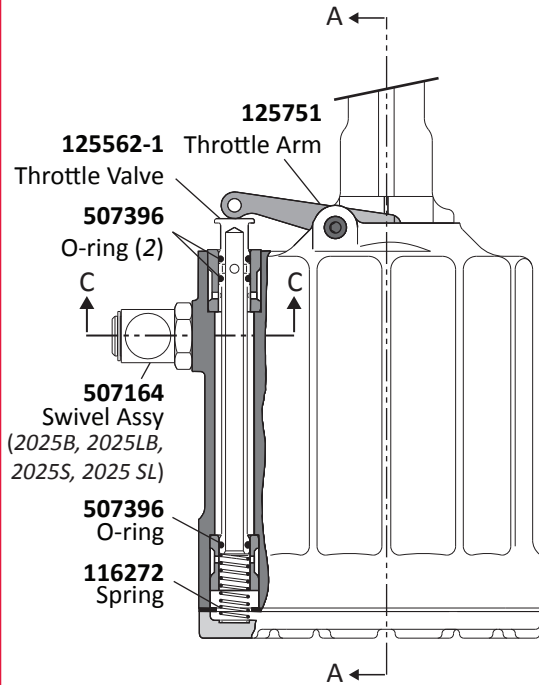

**SECTION A-A**

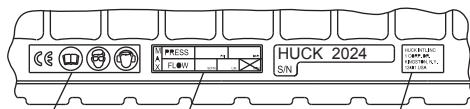

- 590350 CE Sticker
- 590351 Max. Pressure and Flow Sticker
- 590347 HUCK Address Sticker

\*\* These stickers are at the base of Cylinder Assembly 125733; they MUST be purchased and placed as shown if they become damaged, lost, or unreadable, or if the Cylinder Assembly is replaced.

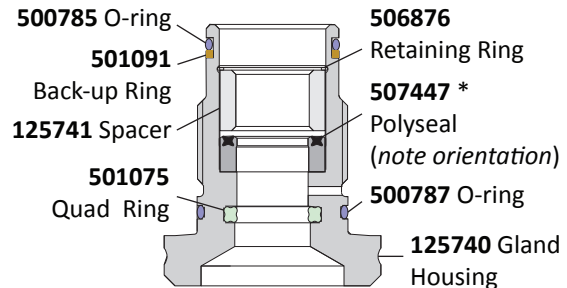

**125742 GLAND ASSEMBLY**  
 Tighten and torque to 36–66 ft.-lbs.

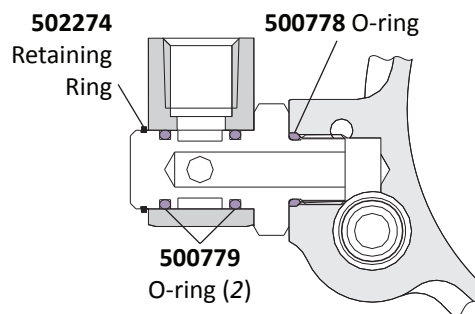

**507164 SWIVEL ASSEMBLY**  
**SECTION C-C**



# Tool Head (2025, 2025L, 2025S & 2025SL)

Figure 14A

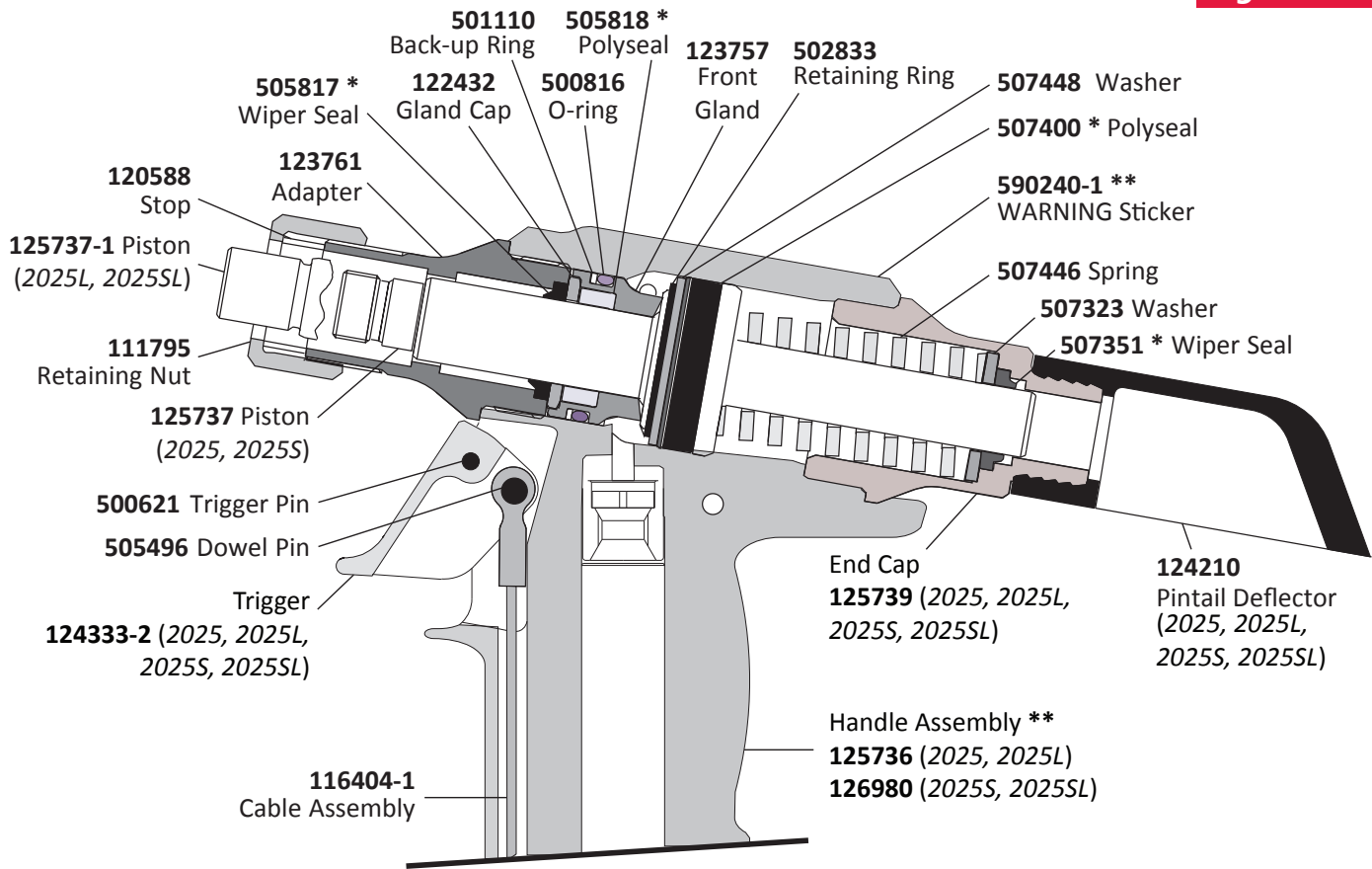

SECTION A-A

\* Note orientation of Wipers and Polyseals.

\*\* WARNING sticker (590240-1) MUST be purchased and placed as shown when it becomes damaged, lost, or unreadable, or if the *Handle Assembly* is replaced.

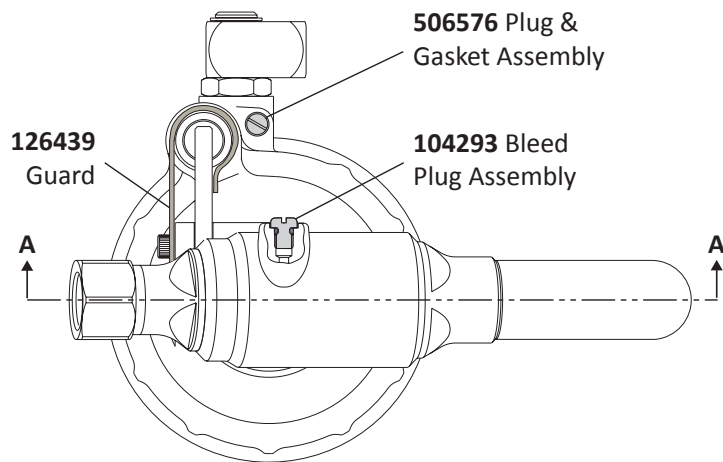

TOOL HEAD (Top View)





# Tool Head (2025V, 2025LV, 2025B & 2025LB)

Figure 15

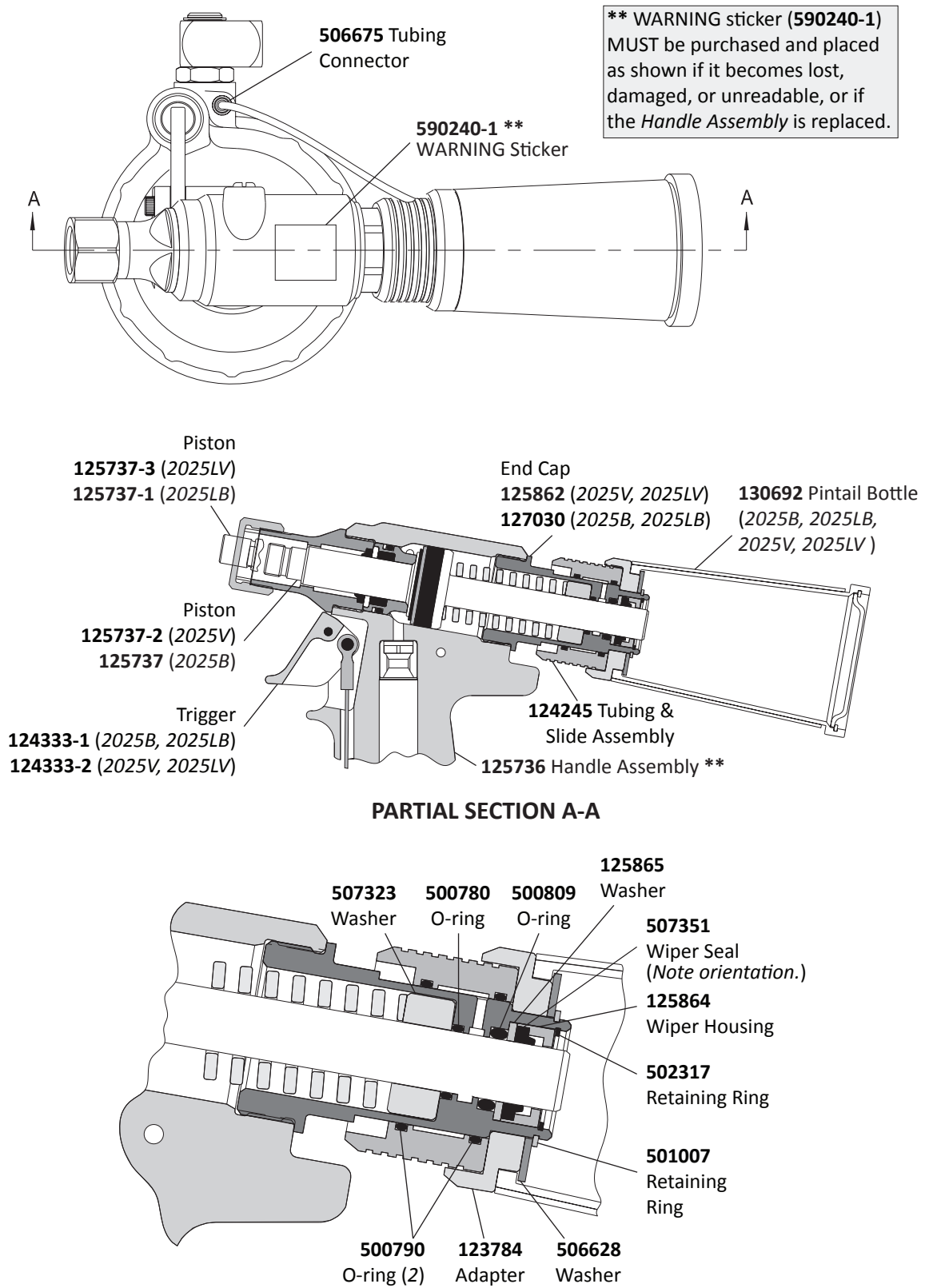



## Kits & Accessories

**Fill Bottle Assembly** (Figure 9) - 120337

### Stall Nuts

2025, 2025B, 2025S, 2025V - 124090

2025L, 2025LB, 2025SL, 2025LV - 125340

### Assembly Tool Kits

 (Figure 3)

2025, 2025B, 2025S, 2025V - 123110-6  
 Polyseal Insertion Tool - 121694-2025  
 Piston Assembly Tool - 123111-2  
 Spacer - 123112-2

2025L, 2025LB, 2025SL, 2025LV - 123110-8  
 Polyseal Insertion Tool - 121694-2025  
 Piston Assembly Tool - 123111-4  
 Spacer - 123112-3

### Service Kits

2025, 2025B, 2025L, 2025S, 2025SL, 2025LB - 2025KIT  
 2025V, 2025LV - 2025VKIT

### Conversion Kits

Convert 2025L to 2025LV - 126190  
 Pintail Collection Bottle - 123772  
 Tubing & Slide Assembly - 124245  
 Piston Assembly - 125738-3  
 End Cap Assembly - 125863

Convert 2025 to 2025V - 126432  
 Pintail Collection Bottle - 123772  
 Tubing & Slide Assembly - 124245  
 Piston Assembly - 125738-2  
 End Cap Assembly - 125863  
 Vacuum Attach Adapter - 123784  
 Retaining Ring Ext. - 501007  
 Flat Washer - 506628  
 Straight Connector - 506675

## Troubleshooting

Always check the simplest possible cause (such as a loose or disconnected trigger line) of a malfunction first. Then proceed logically, eliminating other possible causes until the cause is discovered. Where possible, substitute known good parts for suspected defective parts. Use this Troubleshooting information to aid in locating and correcting trouble.

1. Tool fails to operate when trigger is pressed.
  - a. Air line not connected.
  - b. Throttle valve O-rings worn or damaged.
  - c. Throttle valve cable is broken.
2. Tool does not complete fastener installation and break pintail.
  - a. Air pressure too low.
  - b. Worn or damaged air piston Quad-ring.
  - c. Tool is low on hydraulic fluid. See the FILL AND BLEED section.
  - d. Air in hydraulic system. See the FILL AND BLEED section.
3. Pintail stripped and/or swaged collar not ejected.
  - a. Check for broken or worn jaws in nose assembly.
  - b. Check for worn anvil.
4. Hydraulic fluid exhausts with air or leaks at base of handle.
  - a. Worn or damaged gland assembly. Inspect Polyseal, O-rings, Quad-ring, and Back-up ring. Replace if necessary.
5. Hydraulic fluid leaks at rear of pull piston.
  - a. Worn or damaged piston Polyseal. Replace if necessary.
6. Hydraulic fluid leaks at front of pull piston.
  - a. Worn or damaged front gland. Inspect Polyseal, O-ring, and Back-up ring. Replace if necessary.
7. Pull piston will not return.
  - a. Throttle valve stuck; lubricate O-rings.
  - b. Throttle arm, cable, or trigger binding.
8. Air leaks at air Cylinder Head.
  - a. Worn or damaged O-ring. Replace if necessary.



## Limited Warranties

### Limited Lifetime Warranty on BobTail® Tools:

Huck International, Inc. warrants to the original purchaser that its BobTail® installation tools manufactured after 12/1/2016 shall be free from defects in materials and workmanship for its **useful lifetime**. This warranty does not cover special order / non-standard products, or part failure due to normal wear, tool abuse or misapplication, or user non-compliance with the service requirements and conditions detailed in the product literature.

### Two Year Limited Warranty on Installation Tools:

Huck International, Inc. warrants that its installation tools and Powerig® hydraulic power sources manufactured after December 1, 2016 shall be free from defects in materials and workmanship for a period of two years from date of purchase by the end user. This warranty does not cover special order / non-standard products, or part failure due to normal wear, tool abuse or misapplication, or user non-compliance with the service requirements and conditions detailed in the product literature.

### 90 Day Limited Warranty on Nose Assemblies and Accessories:

Huck International, Inc. warrants that its nose assemblies and accessories shall be free from defects in materials and workmanship for a period of 90 days from date of purchase by the end user. This warranty does not cover special clearance noses, or special order / non-standard product, or part failure due to normal wear, abuse or misapplication, or user non-compliance with the service requirements and conditions detailed in the product literature.

**Useful lifetime** is defined as the period over which the product is expected to last physically, up to the point when replacement is required due to either normal in-service wear, or as part of a complete overhaul. Determination is made on a case-by case basis upon return of parts to Huck International, Inc. for evaluation.

### Tooling, Part(s) and Other Items not manufactured by Huck:

HUCK makes no warranty with respect to the tooling, part(s), or other items manufactured by third parties. HUCK expressly disclaims any warranty expressed or implied, as to the condition, design, operation, merchantability, or fitness for use of any tool, part(s), or other items thereof not manufactured by HUCK. HUCK shall not be liable for any loss or damage, directly or indirectly, arising from the use of such tooling, part(s), or other items or breach of warranty or for any claim for incidental or consequential damages.

Huck shall not be liable for any loss or damage resulting from delays or non-fulfillment of orders owing to strikes, fires, accidents, transportation companies or for any reason or reasons beyond the control of the Huck or its suppliers.

### Huck Installation Equipment:

Huck International, Inc. reserves the right to make changes in specifications and design and to discontinue models without notice.

Huck Installation Equipment should be serviced by trained service technicians only.

Always give the serial number of the equipment when corresponding or ordering service parts.

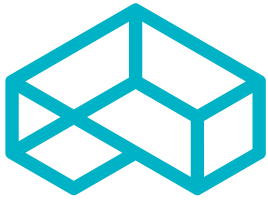

**ARCONIC**

Arconic Inc. (NYSE: ARNC) creates breakthrough products that shape industries. Working in close partnership with our customers, we solve complex engineering challenges to transform the way we fly, drive, build and power.

Through the ingenuity of our people and cutting-edge advanced manufacturing, we deliver these products at a quality and efficiency that ensures customer success and shareholder value.

	<p>© 2018 Huck International, Inc. <b>Arconic Fastening Systems</b></p>
---	---



Huck provides technical assistance regarding the use and application of Huck fasteners and tooling. **NOTICE:** The information contained in this publication is only for general guidance with regard to properties of the products shown and/or the means for selecting such products, and is not intended to create any warranty, express, implied, or statutory; all warranties are contained only in Huck's written quotations, acknowledgments, and/or purchase orders. It is recommended that the user secure specific, up-to-date data and information regarding each application and/or use of such products.

This product distributed by

# Applifast.

251 Cree Crescent Winnipeg Manitoba Canada R3J 3X4

Tel: 204 837 8361 | Fax: 204 837 3520 | [info@applifast.com](mailto:info@applifast.com)  
1 800 563 1293 | 1 800 974 1394 | [applifast.com](http://applifast.com)



*"We succeed when you succeed"*