

**Alcoa  
Fastening  
Systems**



**INSTRUCTION MANUAL**

**202 SERIES**

***PNEUDRAULIC INSTALLATION TOOLS***

**ALL MODELS**

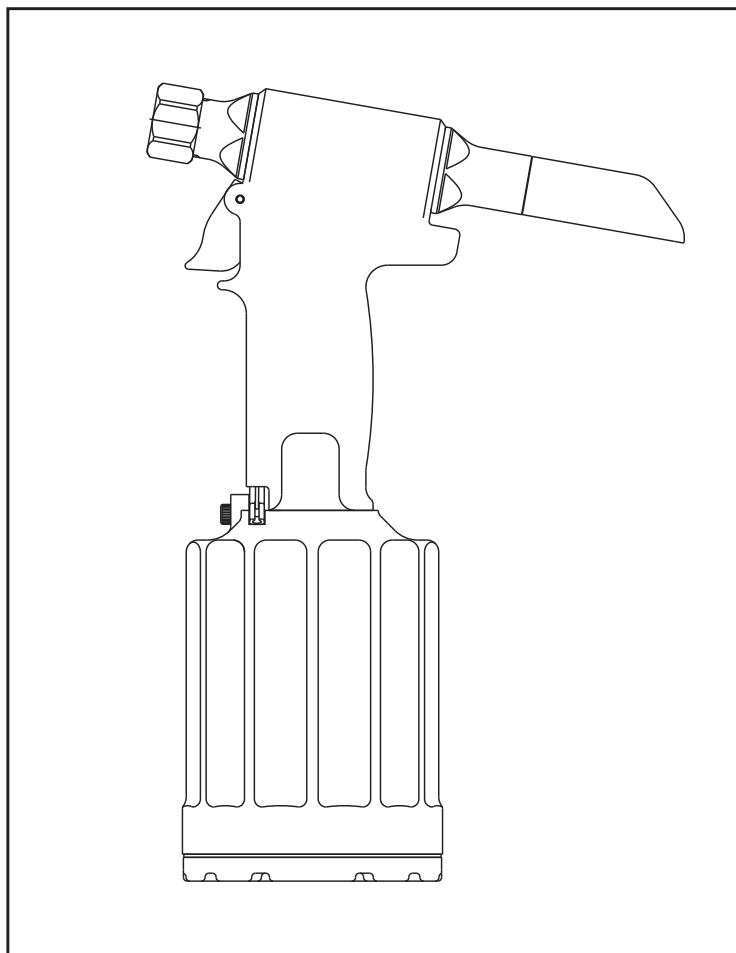

Makers of Huck®, Marson®, Recoil®  
Brand Fasteners, Tools & Accessories





# EC Declaration of Conformity

**Manufacturer:**

Huck International, LLC, Industrial Products Group, 1 Corporate Drive, Kingston, NY, 12401, USA

**Description of Machinery:**

Models 202, 202#, ERT9, & ERT9# series pneudraulic installation tools and specials based on their design (e.g. PR####).

**Relevant provisions complied with:**

Council Directive related to Machinery (2006/42/EC)

British Standard related to hand held, non-electric power tools (ISO 11148-1:2011)

**European Representative:**

Rob Pattenden, Huck International, Ltd. Unit C Stafford Park 7, Telford Shropshire TF3 3BQ, England, United Kingdom

**Authorized Signature/date:**

I, the undersigned, do hereby declare that the equipment specified above conforms to the above Directive(s) and Standard(s).

Signature:

Full Name: Robert B. Wilcox

Position: Engineering Manager

Location: Huck International, LLC d/b/a Alcoa Fastening Systems  
Kingston, New York, USA

Date: 27/02/2013

**Declared dual number noise emission values in accordance with ISO 4871**

A weighted sound power level, LWA: **81** dB (reference 1 pW)  
Uncertainty, KWA: 3 dB

A weighted emission sound pressure level at the work station, LpA: **70** dB  
(reference 20  $\mu$ Pa)  
Uncertainty, KpA: 3 dB

C-weighted peak emission sound pressure level, LpC, peak: **115** dB  
(reference 20  $\mu$ Pa)  
Uncertainty, KpC: 3 dB

Values determined according to noise test code ISO 15744, using as basic standards ISO 3744 and ISO 11203. The sum of a measured noise emission value and its associated uncertainty represents an upper boundary of the range of values which is likely to occur in measurements.

**Declared vibration emission values in accordance with EN 12096**

Measured Vibrations emission value, a: **.57** m/s<sup>2</sup>

Uncertainty, K: **.28** m/s<sup>2</sup>

Values measured and determined according to ISO 28662-1, ISO 5349-2, and EN 1033

*Test data to support the above information is on file at Alcoa Fastening Systems, Industrial Products Group, Kingston Operations, Kingston, NY, USA.*



## **CONTENTS**

<b>EU DECLARATION OF CONFORMITY</b> .....	<b>.2</b>
<b>SAFETY</b> .....	<b>.4</b>
<b>SPECIFICATIONS</b> .....	<b>.5-7</b>
<b>PRINCIPLE OF OPERATION</b> .....	<b>.8</b>
<b>PREPARATION FOR USE</b> .....	<b>.9</b>
<b>OPERATING INSTRUCTIONS</b> .....	<b>.9</b>
<b>SERVICING THE TOOL</b> .....	<b>.10</b>
<b>DISASSEMBLY</b> .....	<b>.11-13</b>
<b>ASSEMBLY</b> .....	<b>.14-15</b>
<b>FILL AND BLEED</b> .....	<b>.16</b>
<b>MEASURING TOOL STROKE</b> .....	<b>.17</b>
<b>ASSEMBLY DRAWINGS</b> .....	<b>.18-19</b>
<b>PARTS LIST</b> .....	<b>.20-21</b>
<b>TROUBLESHOOTING</b> .....	<b>.22</b>
<b>KITS &amp; ACCESSORIES</b> .....	<b>.22</b>



# SAFETY INSTRUCTIONS

## GLOSSARY OF TERMS AND SYMBOLS:



- Product complies with requirements set forth by the relevant European directives.



- **READ MANUAL** prior to using this equipment.



- **EYE PROTECTION IS REQUIRED** while using this equipment.



- **HEARING PROTECTION IS REQUIRED** while using this equipment.



**WARNINGS: Must be understood to avoid severe personal injury.**



**CAUTIONS: show conditions that will damage equipment and or structure.**

**Notes:** are reminders of required procedures.

**Bold, Italic type and underlining:** emphasizes a specific instruction.

### I. GENERAL SAFETY RULES:

1. A half hour long hands-on training session with qualified personnel is recommended before using Huck equipment.
2. Huck equipment must be maintained in a safe working condition at all times. Tools and hoses should be inspected at the beginning of each shift/day for damage or wear. Any repair should be done by a qualified repairman trained on Huck procedures.
3. For multiple hazards, read and understand the safety instructions before installing, operating, repairing, maintaining, changing accessories on, or working near the assembly power tool. Failure to do so can result in serious bodily injury.
4. Only qualified and trained operators should install, adjust or use the assembly power tool.
5. Do not modify this assembly power tool. This can reduce effectiveness of safety measures and increase operator risk.
6. Do not discard safety instructions; give them to the operator.
7. Do not use assembly power tool if it has been damaged.
8. Tools shall be inspected periodically to verify all ratings and markings required, and listed in the manual, are legibly marked on the tool. The employer/operator shall contact the manufacturer to obtain replacement marking labels when necessary. Refer to assembly drawing and parts list for replacement.
9. Tool is only to be used as stated in this manual. Any other use is prohibited.
10. Read MSDS Specifications before servicing the tool. MSDS specifications are available from the product manufacturer or your Huck representative.
11. Only genuine Huck parts shall be used for replacements or spares. Use of any other parts can result in tooling damage or personal injury.
12. Never remove any safety guards or pintail deflectors.
13. Never install a fastener in free air. Personal injury from fastener ejecting may occur.
14. Where applicable, always clear spent pintail out of nose assembly before installing the next fastener.
15. Check clearance between trigger and work piece to ensure there is no pinch point when tool is activated. Remote triggers are available for hydraulic tooling if pinch point is unavoidable.
16. Do not abuse tool by dropping or using it as a hammer. Never use hydraulic or air lines as a handle or to bend or pry the tool. Reasonable care of installation tools by operators is an important factor in maintaining tool efficiency, eliminating downtime, and preventing an accident which may cause severe personal injury.
17. Never place hands between nose assembly and work piece. Keep hands clear from front of tool.
18. Tools with ejector rods should never be cycled with out nose assembly installed.
19. When two piece lock bolts are being used always make sure the collar orientation is correct. See fastener data sheet for correct positioning.

### II. PROJECTILE HAZARDS:

1. Risk of whipping compressed air hose if tool is pneudraulic or pneumatic.
2. Disconnect the assembly power tool from energy source when changing inserted tools or accessories.
3. Be aware that failure of the workpiece, accessories, or the inserted tool itself can generate high velocity projectiles.
4. Always wear impact resistant eye protection during tool operation. The grade of protection required should be assessed for each use.
5. The risk of others should also be assessed at this time.
6. Ensure that the workpiece is securely fixed.
7. Check that the means of protection from ejection of fastener or pintail is in place and operative.

8. There is possibility of forcible ejection of pintails or spent mandrels from front of tool.

### III. OPERATING HAZARDS:

1. Use of tool can expose the operator's hands to hazards including: crushing, impacts, cuts, abrasions and heat. Wear suitable gloves to protect hands.
2. Operators and maintenance personnel shall be physically able to handle the bulk, weight and power of the tool.
3. Hold the tool correctly and be ready to counteract normal or sudden movements with both hands available.
4. Maintain a balanced body position and secure footing.
5. Release trigger or stop start device in case of interruption of energy supply.
6. Use only fluids and lubricants recommended by the manufacturer.
7. Avoid unsuitable postures, as it is likely for these not to allow counteracting of normal or unexpected tool movement.
8. If the assembly power tool is fixed to a suspension device, make sure that fixation is secure.
9. Beware of the risk of crushing or pinching if nose equipment is not fitted.

### IV. REPETITIVE MOTION HAZARDS:

1. When using assembly power tool, the operator can experience discomfort in the hands, arms, shoulders, neck or other parts of the body.
2. When using tool, the operator should adopt a comfortable posture while maintaining a secure footing and avoid awkward or off balanced postures.
3. The operator should change posture during extended tasks to help avoid discomfort and fatigue.
4. If the operator experiences symptoms such as persistent or recurring discomfort, pain, throbbing, aching, tingling, numbness, burning sensations or stiffness, these warnings should not be ignored. The operator should tell the employer and consult a qualified health professional.

### V. ACCESSORIES HAZARDS:

1. Disconnect tool from energy supply before changing inserted tool or accessory.
2. Use only sizes and types of accessories and consumables that are recommended. Do not use other types or sizes of accessories or consumables.

### VI. WORKPLACE HAZARDS:

1. Be aware of slippery surfaces caused by use of the tool and of trip hazards caused by the air line or hydraulic hose.
2. Proceed with caution while in unfamiliar surroundings; there could be hidden hazards such as electricity or other utility lines.
3. The assembly power tool is not intended for use in potentially explosive environments.
4. Tool is not insulated against contact with electrical power.
5. Ensure there are no electrical cables, gas pipes, etc., which can cause a hazard if damaged by use of the tool.

### VII. NOISE HAZARDS:

1. Exposure to high noise levels can cause permanent, disabling hearing loss and other problems such as tinnitus, therefore risk assessment and the implementation of proper controls is essential.
2. Appropriate controls to reduce the risk may include actions such as damping materials to prevent workpiece from 'ringing'.
3. Use hearing protection in accordance with employer's instructions and as required by occupational health and safety regulations.
4. Operate and maintain tool as recommended in the instruction handbook to prevent an unnecessary increase in the noise level.
5. Select, maintain and replace the consumable / inserted tool as recommended to prevent an unnecessary increase in noise.
6. If the power tool has a silencer, always ensure that it is in place and in good working order when the tool is being operated.

### VIII. VIBRATION HAZARDS:

1. Exposure to vibration can cause disabling damage to the nerves and blood supply to the hands and arms.
2. Wear warm clothing when working in cold conditions and keep hands warm and dry.
3. If numbness, tingling, pain or whitening of the skin in the fingers or hands, stop using the tool, tell your employer and consult a physician.
4. Support the weight of the tool in a stand, tensioner or balancer in order to have a lighter grip on the tool.

### IX. PNEUMATIC / PNEUDRAULIC TOOL SAFETY INSTRUCTIONS:

1. Air under pressure can cause severe injury.
2. Always shut off air supply, drain hose of air pressure and disconnect tool from air supply when not in use, before changing accessories or when making repairs.
3. Never direct air at yourself or anyone else.
4. Whipping hoses can cause severe injury, always check for damaged or loose hoses and fittings.
5. Cold air should be directed away from hands.
6. Whenever universal twist couplings (claw couplings) are used, lock pins shall be installed and whipcheck safety cables shall be used to safeguard against possible hose to hose or hose to tool connection failure.
7. Do not exceed maximum air pressure stated on tool.
8. Never carry an air tool by the hose.



## SPECIFICATIONS

### Models 202, & 202L

**STROKE:** .75 in (1.90 cm)

**WEIGHT:**

**202 & 202L:** 5.1 lbs (2.31 kg)

**MAX AIR PRESSURE:** 90 psi (6.2 BAR)

**MAX FLOW RATE:** 8.5 scfm (241 l/m)

**CAPACITY:**

3889 lbs (17.3 kN) @ 90 psi (6.2 BAR)

**SPEED/CYCLES:** 20 per minute

**MAX OPERATING TEMPERATURE:**

125° F (52° C)

**POWER SOURCE:**

90psi MAX shop air

**HYDRAULIC FLUID:**

ATF meeting DEXRON III, DEXRON IV, MERCON, Allison C-4 or equivalent specifications. Fire resistant hydraulic fluid may also be used, and is required to comply with OSHA regulation 1926.302 paragraph (d): "the fluid used in hydraulic power tools shall be fire resistant fluid approved under schedule 30 of the US Bureau of Mines, Department of Interior, and shall retain its operating characteristics at the most extreme temperatures to which it will be exposed."

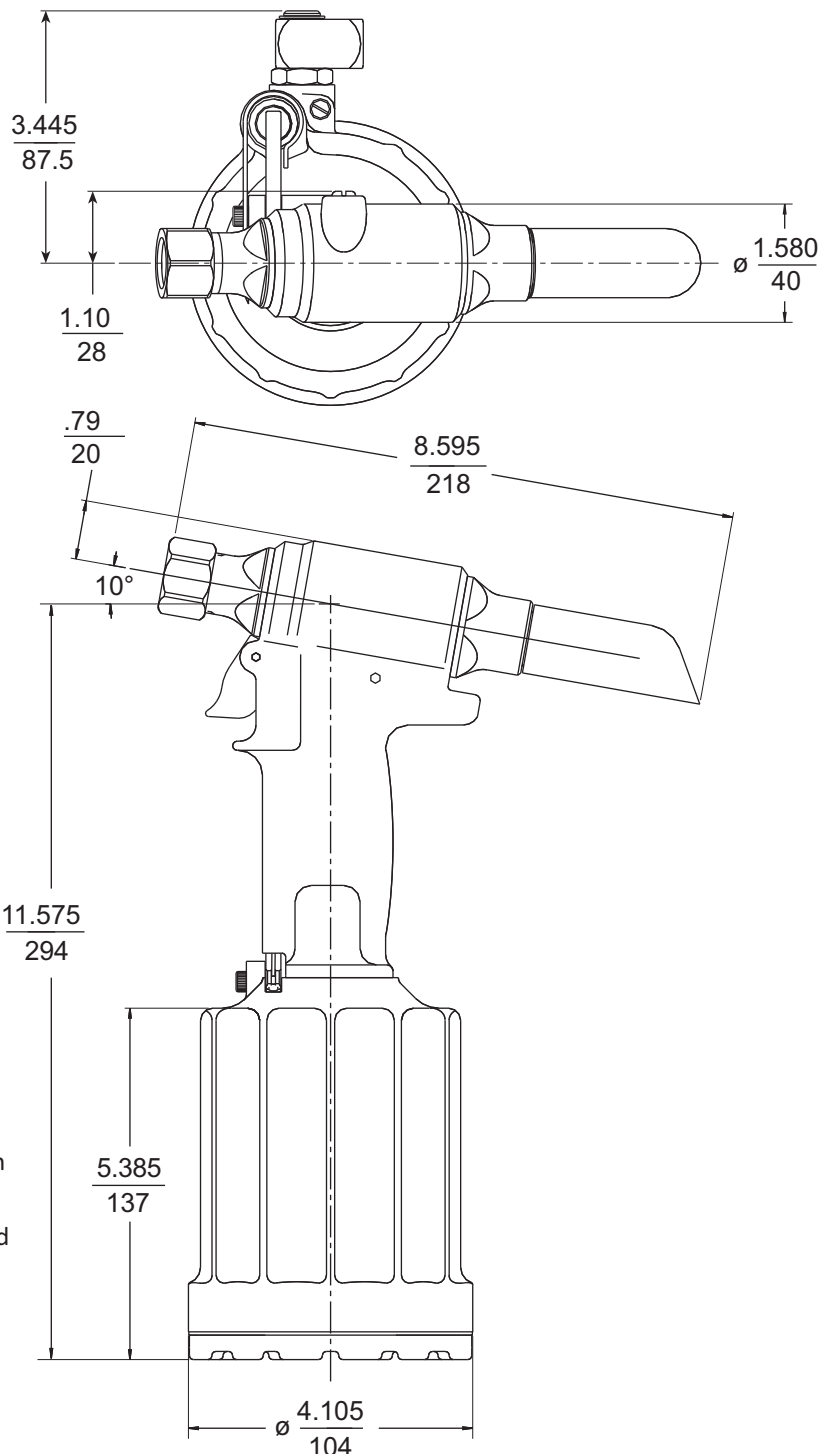





## SPECIFICATIONS

### Models 202V, & 202LV

**STROKE:** .75 in (1.90 cm)

**WEIGHT:**

**202V & 202LV:** 5.4 lbs (2.45 kg)

**MAX AIR PRESSURE:** 90 psi (6.2 BAR)

**MAX FLOW RATE:** 8.5 scfm (241 l/m)

**CAPACITY:**

3889 lbs (17.3 kN) @ 90 psi (6.2 BAR)

**SPEED/CYCLES:** 20 per minute

**MAX OPERATING TEMPERATURE:**

125° F (52° C)

**POWER SOURCE:**

90psi MAX shop air

**HYDRAULIC FLUID:**

ATF meeting DEXRON III, DEXRON IV, MERCON, Allison C-4 or equivalent specifications.

Fire resistant hydraulic fluid may also be used, and is required to comply with OSHA regulation 1926.302 paragraph (d): "the fluid used in hydraulic power tools shall be fire resistant fluid approved under schedule 30 of the US Bureau of Mines, Department of Interior, and shall retain its operating characteristics at the most extreme temperatures to which it will be exposed."

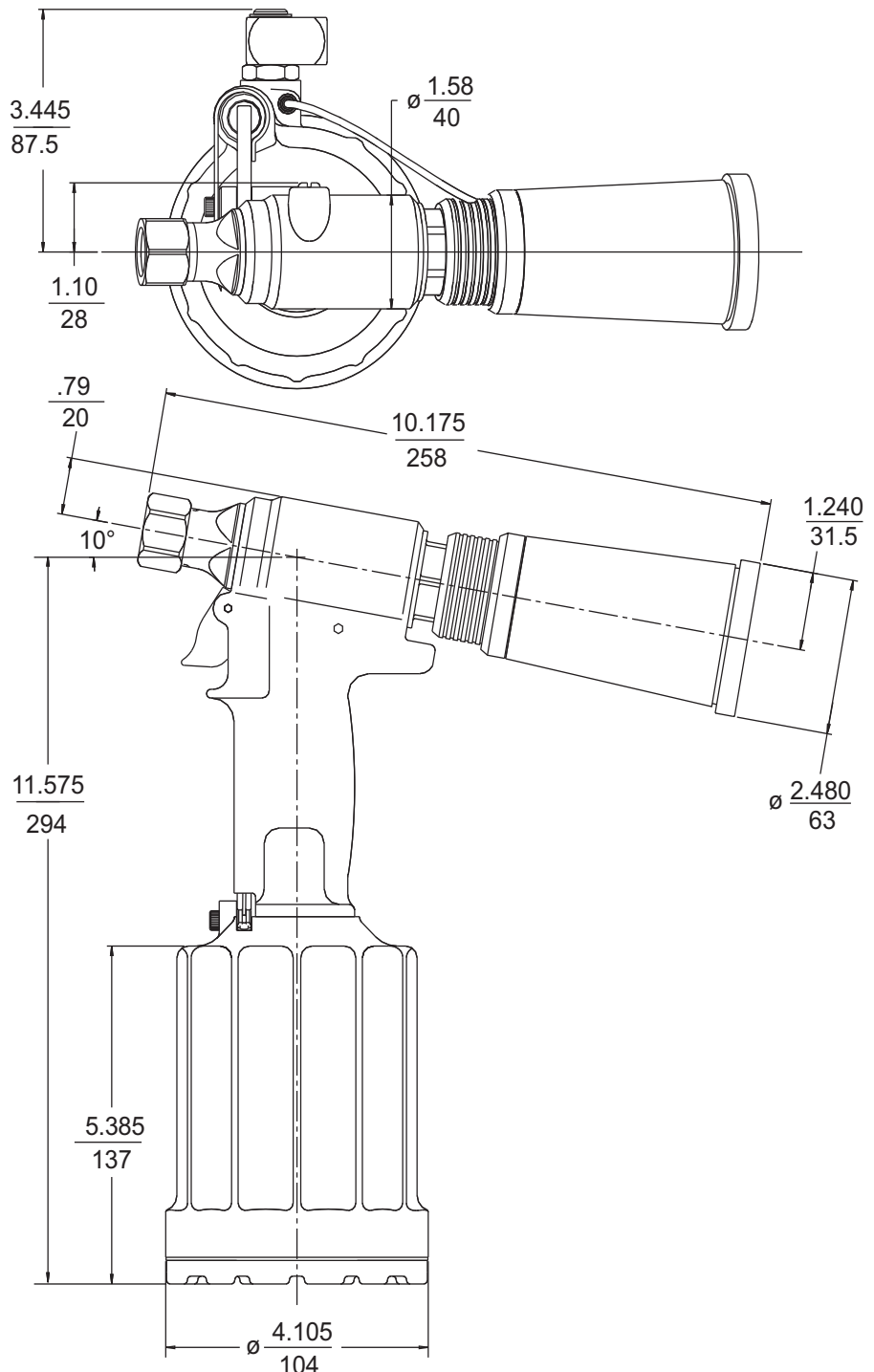



## SPECIFICATIONS

# Model 202B

**STROKE:** .75 in (1.90 cm)

**WEIGHT:**

**202V & 202LV:** 5.4 lbs (2.45 kg)

**MAX AIR PRESSURE:** 90 psi (6.2 BAR)

**MAX FLOW RATE:** 8.5 scfm (241 l/m)

**CAPACITY:**

3889 lbs (17.3 kN) @ 90 psi (6.2 BAR)

**SPEED/CYCLES:** 20 per minute

**MAX OPERATING TEMPERATURE:**

125° F (52° C)

**POWER SOURCE:**

90psi MAX shop air

**HYDRAULIC FLUID:**

ATF meeting DEXRON III, DEXRON IV, MERCON, Allison C-4 or equivalent specifications.

Fire resistant hydraulic fluid may also be used, and is required to comply with OSHA regulation 1926.302 paragraph (d): "the fluid used in hydraulic power tools shall be fire resistant fluid approved under schedule 30 of the US Bureau of Mines, Department of Interior, and shall retain its operating characteristics at the most extreme temperatures to which it will be exposed."

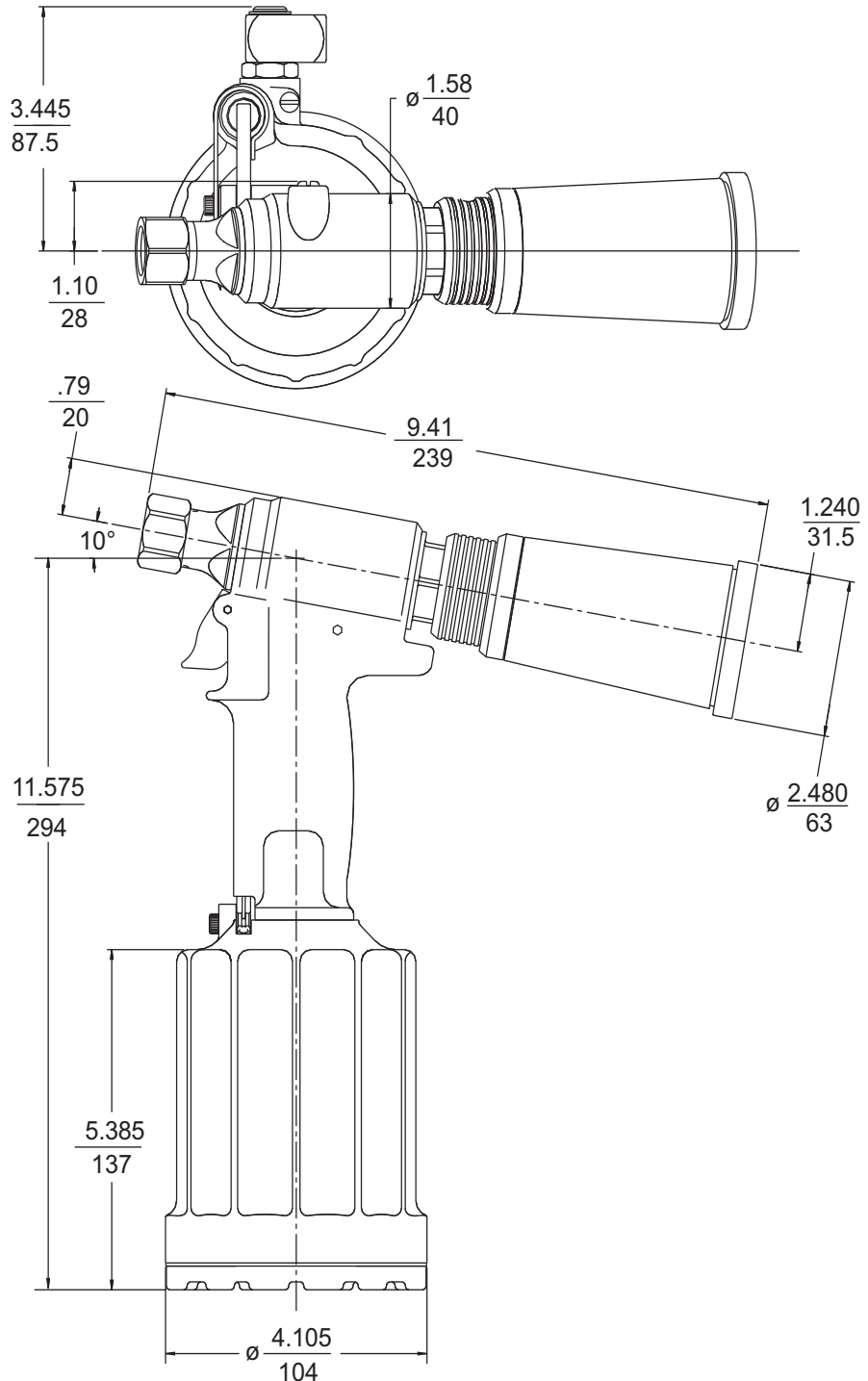



## PRINCIPLE OF OPERATION

When the tool is connected to proper air supply, the air pressure holds the Throttle Valve in the up (RETURN) position.

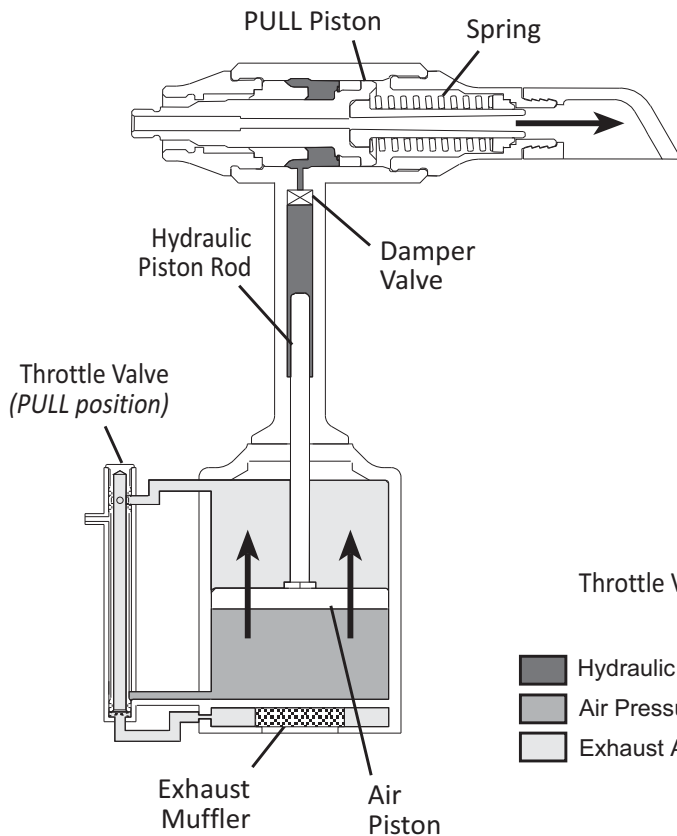

Fig. 2a

### PULL STROKE

When the tool is connected to the air supply, air pressure holds the **Throttle Valve** in the UP position, and air pressure is directed to the top of the **Air Piston** keeping it down.

When the trigger is depressed, the **Throttle Valve** moves to the DOWN position, and pressurized air is directed to the bottom of the **Air Piston**, causing it to move upward (Fig.2a). The air above the piston is exhausted and directed through the center of the **Throttle Valve** and out the bottom of the tool through the **Muffler**.

As the **Hydraulic Piston Rod** moves upward, a column of fluid is forced into the tool head, which moves the **PULL Piston** rearward. The attached nose assembly moves with the **PULL Piston** to start fastener installation.

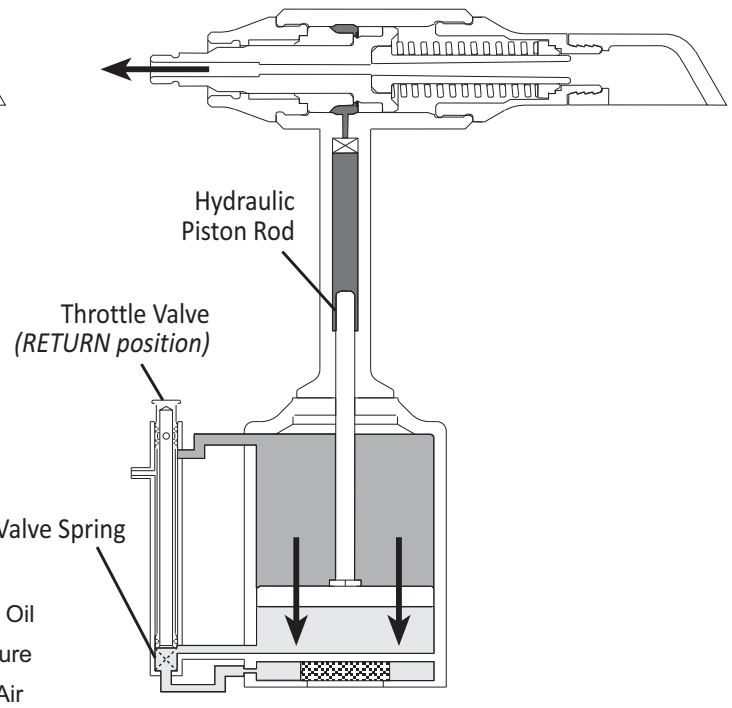

Fig. 2b

### RETURN STROKE

When fastener installation is completed, and upon trigger release, air pressure with the assistance of a **Throttle Valve Spring** causes the **Throttle Valve** to return to its UP position.

Pressurized air is re-directed to the top of the **Air Piston** (Fig.2b), causing the **Air Piston** and **Hydraulic Piston Rod** to move downward. The air from below the piston is exhausted through the **Muffler** at the bottom of the tool.

As the **Hydraulic Piston Rod** moves downward and hydraulic pressure is released from the **PULL Piston**, a **Spring** behind the **PULL Piston** returns it to its forward position.

The **Damper Valve** impedes oil flow at pinbreak helping prevent “Tool Kick”.





## PREPARATION FOR USE

The Model 202 Installation Tools are shipped with a plastic plug in the air inlet connector. The connector has 1/4-18 female pipe threads to accept the air hose fitting. Quick disconnect fittings and 1/4" inside diameter air hose are recommended. An air supply of 90 - 100 psi capable of 20 CFM must be available. Air supply should be equipped with a filter-regulator-lubricator unit.

1. Remove plastic shipping plug from Air Inlet Connector and put in a few drops of Automatic Transmission Fluid, DEXRON III, or equivalent.
2. Screw quick disconnect fitting into Air Inlet Connector.



**CAUTION: Do not use TEFLON tape on threads. Use TEFLON in stick form only. (Huck P/N 503237)**

3. Set air pressure on regulator to 90-100 psi.
4. Connect air hose to tool.
5. Cycle tool a few times by depressing and releasing trigger.
6. Disconnect air hose from tool.

7. Remove Retaining Nut at front of tool.
8. Select proper Nose Assembly for fastener to be installed.
9. Screw Collet Assembly (including lock collar and shim if applicable) onto Spindle. (Wrench Tight)
10. Slide Anvil over Collet Assembly and into counterbore.
11. Slide Retaining Nut over Anvil and screw Nut onto Head.
12. Connect air hose to tool and install fastener(s) in test plate of proper thickness with proper size holes. Inspect fastener(s).

### **NOTES:**

- 1 Air quick disconnect fittings and air hoses are not available from Huck International, Inc.
- 2 On old style nose assemblies with lock collars, **VIBRA-TITE**, or equivalent, should be used on collet threads, since there is no staking hole provided on the 202 Pull Piston.

## OPERATING INSTRUCTIONS

**NOTE:** 202V and 202LV are sold with the ribbed vacuum control ON/OFF slide in the forward or OFF position. See Figure 10 for slides location which is shown in the ON (rear) position. While tool is not being used, move slide to the OFF (forward) position to prevent unnecessary air loss.

### **Blind Fastener Installation:**

The fastener may be placed either in the work hole or in the end of the nose assembly. In either case, tool and nose assembly must be held against work and at right angles to it. Depress trigger and hold it depressed until fastener is installed and pintail breaks. Release trigger.

### **MAGNA-GRIP® Fastener Installation:**

Place pin in work-hole and place collar over pin. See **WARNINGS**. (If collar has only one tapered end, that end **MUST** be out toward tool.) Hold pin in hole. Push nose assembly onto pin protruding from collar until anvil touches collar. Press trigger and hold down until collar is swaged and pintail breaks. Release trigger.



**CAUTION: Remove excessive gap from between sheets for enough of the pintail to stick out of the collar for all of the jaw teeth to grip into the pintail grooves. Jaws not fully gripping pintail grooves will be stripped or broken.**



### **WARNINGS:**

**Inspect tool for damage or wear before each use. Do not operate if damaged or worn as severe personal injury may occur.**

**Pulling on a pin (fastener) without a collar, or with collar chamfer against workpiece, may result in pin becoming a high speed projectile when pin grooves are stripped or pintail breaks off. Fatal or severe injury is possible to anyone in the pins line of flight. This includes pins that ricochet.**

**Broken pintails eject from deflector with speed and force. Be sure pintail deflector is directed safely away front operator or the personnel in the area. Ejecting pintails striking anyone may cause serious personal injury. For Models 202B and 202V, pintail bottles must always be used. Replace damaged pintail deflectors and bottles as serious personal injury may occur from pintails when using these defective parts.**



## SERVICING THE TOOL

### GENERAL

1. The efficiency and life of any tool depends upon proper maintenance. Regular inspection and correction of minor problems will keep tool operating efficiently and prevent downtime. The tool should be serviced by personnel who are thoroughly familiar with how it operates.
2. A clean, well-lighted area should be available for servicing the tool. Special care must be given to prevent contamination of pneumatic and hydraulic systems.
3. Proper hand tools, both standard and special, must be available.
4. All parts must be handled carefully and examined for damage or wear. Always replace Seals, when tool is disassembled for any reason. Components should be disassembled and assembled in a straight line without bending, cocking, or undue force. Disassembly and assembly procedures outlined in this manual should be followed.
5. **Service Parts Kits 202KIT, 202BKIT, and 202VKIT** include consumable parts and should be available at all times. Other components, as experience dictates, should also be available.



**WARNING: Inspect tool for damage or wear before each use. Do not operate if damaged or worn, as severe personal injury may occur.**

### DAILY

1. If a Filter-Regulator-Lubricator unit is not being used, uncouple air disconnects and put a few drops of Automatic Transmission Fluid or light oil into the air inlet of the tool. If the tool is in continuous use, put a few drops of oil in every two to three hours.
2. Bleed the air line to clear it of accumulated dirt or water before connecting air hose to the tool.
3. Check all hoses and couplings for damage or air leaks, tighten or replace if necessary.
4. Check the tool for damage or air/hydraulic leaks, tighten or replace if necessary.
5. Check the nose assembly for tightness or damage, tighten or replace if necessary.
6. Check stroke periodically, if stroke is short add oil.

### WEEKLY

1. Disassemble, clean, and reassemble nose assemblies per applicable nose assembly instructions.
2. Check the tool and all connecting parts for damage or oil/air leaks, tighten or replace if necessary.



## DISASSEMBLY INSTRUCTIONS - ALL MODELS



**WARNING:** Be sure air hose is disconnected from tool before cleaning, or performing maintenance. Severe personal injury may occur if air hose is not disconnected.

For component identification, refer to Figures 14 & 15 and Parts Lists on pages 20 & 21.

**NOTE:** The following procedure is for complete disassembly of tool. Disassemble only components necessary to replace damaged O-rings, Quad rings, Back-up rings, and worn or damaged components. Always use soft jaw vice to avoid damage to tool.

1. Disconnect tool from air source.
2. Unscrew Retaining Nut (7) and remove nose assembly.
3. Unscrew Bleed Plug (55), from top of Handle/head. Turn tool over and allow fluid to drain into container (Fig. 1). Discard fluid.

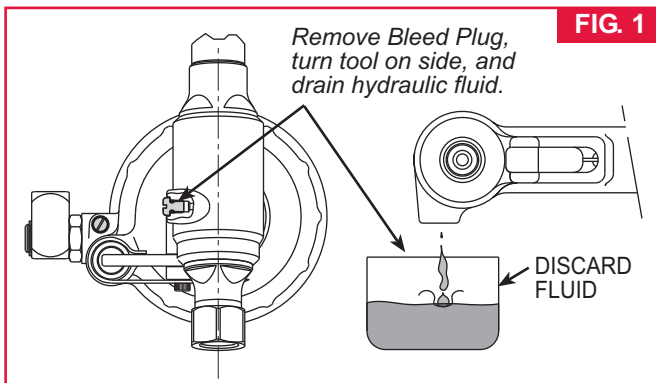

4. **202 & 202L:** Pull Pintail Deflector (24) off of End Cap (21). (Figure 2)  
**202B:** By reaching through the window of Pintail Bottle (24) remove Retaining Ring (62) and Washer (63), then remove Pintail Bottle (24) and Adapter (64). (Figure 5).  
**202V & 202LV:** Please reference *Disassembly of Pintail Bottle and Vacuum System Procedure*.
5. Remove Throttle Arm Pivot Screw (48) and Lever Guard (73), and lift out Throttle Arm (53). Disconnect ball end of Cable Assembly (2) from Throttle Arm.
6. Hold tool in vise with bottom up. (Fig. 2) Remove Button Head Screws (40) with 1/8 hex key. Remove End Cap (41) and Gasket (39). Remove Muffler (42) from end cap. Remove Spring (49) from Throttle Valve (Fig.14).

7. Tap Cylinder Head (45) down with soft mallet (to take pressure off ring), and remove Retaining Ring (38) (Fig.2).
8. Screw Button Head Screws (40) back into Cylinder Head. Carefully pry on screws to remove head. Remove O-ring (46).
9. To remove air piston from cylinder, pull on Lock Nut (43) with vise grips. Remove Quad Ring (47).



**CAUTION:** Care must be given not to scratch piston rod or cylinder during removal.

10. Remove Bumper (34) from Gland Assembly. Unscrew Gland Assembly (25) with 1 3/8 socket wrench and extension bar.
11. First remove Retaining Ring (30) from Gland (26). Pull out Spacer (29) and Polyseal (28). Then remove O-rings (31 & 27), Quad Ring (33), & Back-up Ring (32) (Fig. 14).

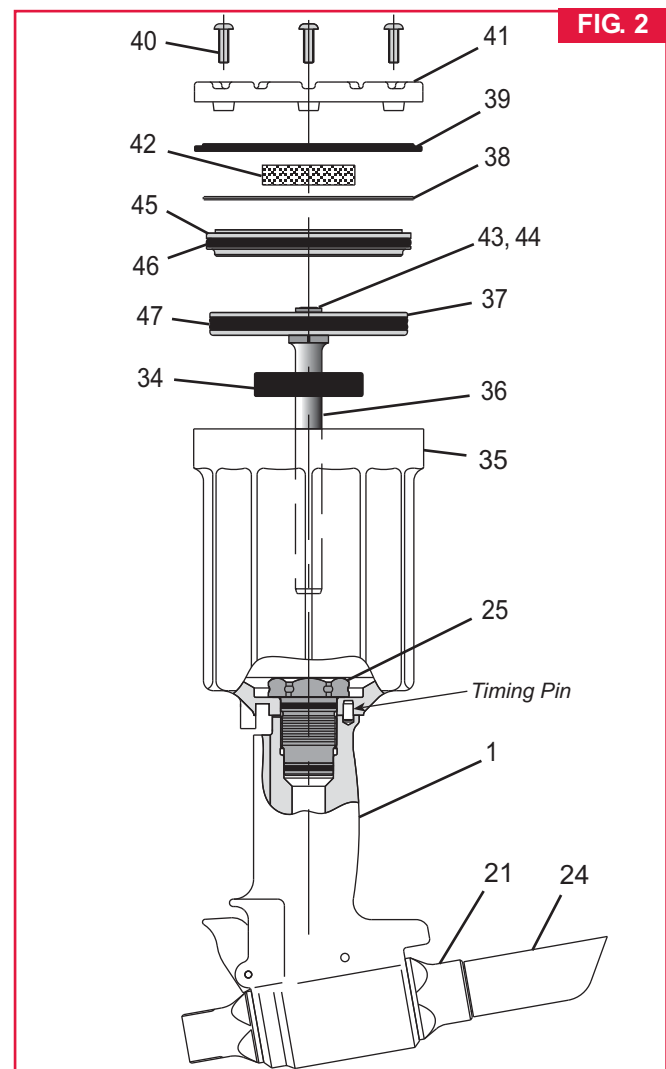



## DISASSEMBLY - ALL MODELS *continued*

12. Lift Cylinder (35) from handle/head (1) (Fig. 2).
13. Turn handle/head (1) over and drain fluid into container. Discard fluid.
14. Pull Throttle Valve (52) out of air Cylinder (35). Remove O-Rings (50) (Fig. 14).

### HEAD/HANDLE 202 & 202L:

15. Unscrew End Cap (21) and remove Spring (19), Spacer (22) and Wiper Seal (23). **NOTE: For 202V please reference Disassembly of Pintail Bottle and Vacuum System procedure.**
16. Thread POLYSEAL Insertion/removal Tool (121694-202), into rear of Handle/head. (Fig. 3)
17. Slide Spacer (123112-2 for 202 or 123112-3 for 202L) onto piston.
18. Thread Piston Assembly Tool (123111-2 for 202 or 123111-4 for 202L) onto piston.
19. Push piston and front gland assemblies out the back of the Handle/Head (1). Allow clearance, with stand-off, for piston as it leaves the tool (Fig. 4).
20. Remove piston assembly tool and spacer from piston. Rethread on the piston assembly tool only, then slide front gland assembly off the Piston (6).
21. Remove Piston Assembly Tool from Piston (6). Remove POLYSEAL Insertion/removal Tool from rear of Head/Handle (1).
23. Remove Retaining Ring (16), Washer (17) and POLYSEAL (18) from piston. **NOTE: Inspect hydraulic piston for wear, scoring or damage. Replace when necessary.**

24. Unscrew Adapter (8) (Fig. 14).
25. Inspect all seals and parts.
24. If frayed or broken, remove trigger Cable Assy (2) by driving Pin (4) out with punch. Remove Dowel Pin (3) to disconnect cable from trigger.

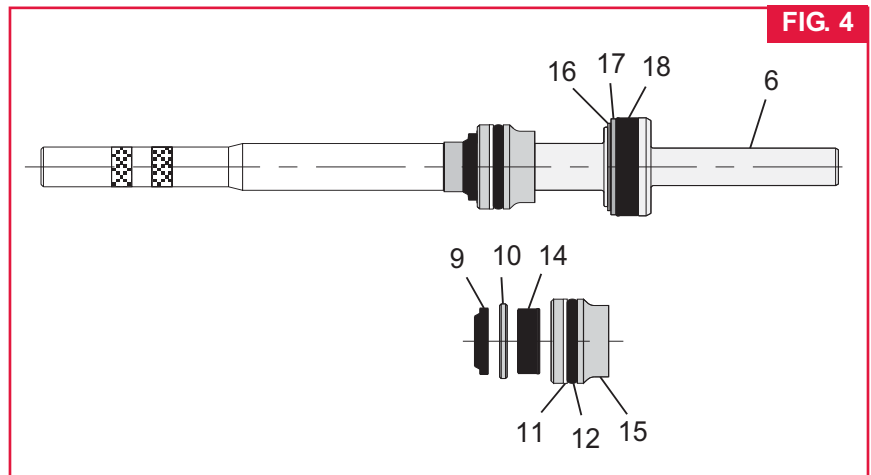
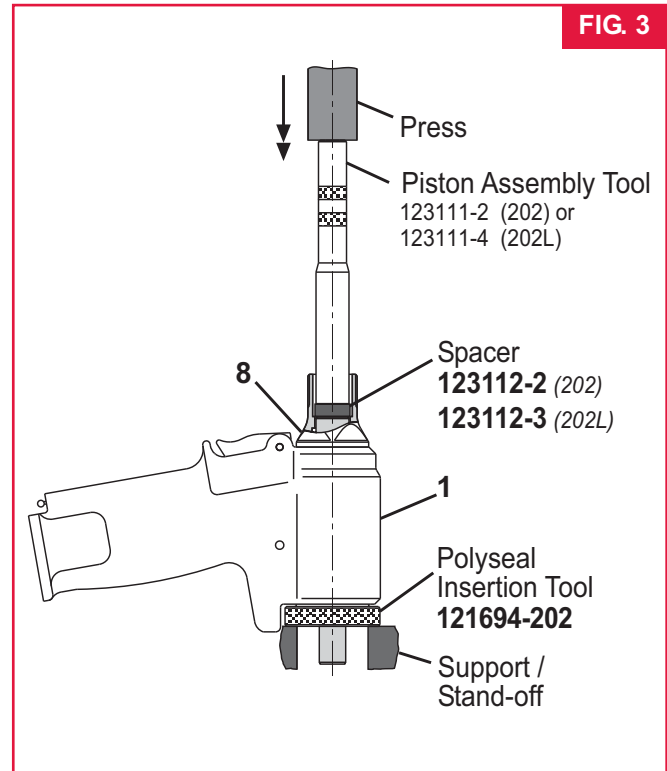



## **DISASSEMBLY - ALL MODELS** *continued*

### **PINTAIL BOTTLE/VACUUM SYSTEM**

**202V & 202LV** (Refer to Figs. 5, 6 & 15)

**NOTE:** The following steps are for the disassembly of the 202V and 202LV models only. Please use these steps in conjunction with the General and Head/Handle disassembly sections of this manual.

1. Reaching through window of Pintail Bottle (24) remove Retaining Ring (62) and Washer (63).
2. Remove Pintail Bottle (24).
3. Disconnect tube from Plug & Gasket Assy (54).
4. Remove Adapter (64) and Tube/ Slide Assy (70).
5. Remove End Cap (21) and Spring (19) (Fig. 6).
6. Remove Spacer (22) and O-Ring (68) from spring side of end cap.
7. From bottle side of end cap, remove Retaining Ring (66), Tube (67), Wiper Seal (23), Washer (71) and O-Ring (69).
8. Remove the O-Rings (65) from the inside of the Adapter and Tube/Slide Assembly (70) (Fig. 15).

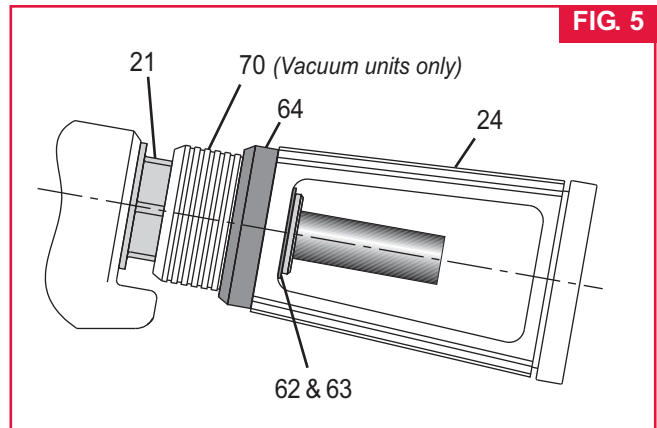

**FIG. 5**

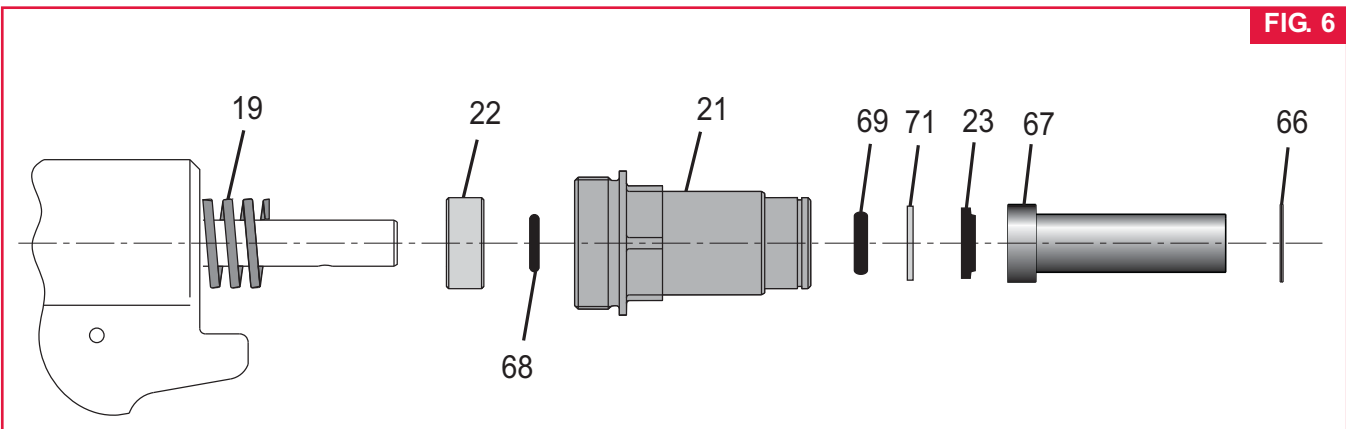

**FIG. 6**



## ASSEMBLY - ALL MODELS

### HEAD/HANDLE 205, 202B, & 202L

**NOTE:** Clean components with mineral spirits, or similar solvent; inspect for wear/damage and replace as necessary. Replace all seals of disassembled components. Use O-rings, QUAD rings and Back-up rings in **Service Parts Kit, P/N 202KIT or 202VKIT**. Smear LUBRIPLATE 130AA or PARKER-O-LUBE on O-rings, QUAD rings, Back-up rings and mating parts to ease assembly. Assemble tool taking care not to damage O-rings, QUAD rings, or Back-up rings.

1. If removed, position Cable Assembly (2) in Trigger (5) slot and slide Dowel Pin (3) through holes in trigger and cable assembly. Position assembled trigger in handle and drive Pin (4) through holes in handle and trigger (Figure 14).
2. Screw Nose Adapter (8) into Head (1) and tighten.
3. Thread POLYSEAL Insertion/removal Tool (121694-202) into head.
4. Assemble piston (6), Polyseal (18) and retaining ring (16) (Figure 7). **Note Polyseal orientation.**

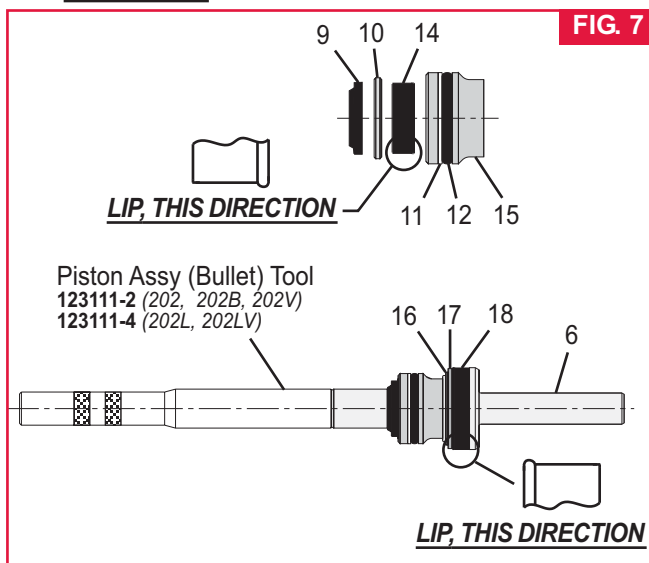

5. Assemble front gland (15), O-ring (12), Back-up ring (11), Polyseal (14) and Gland Cap (10). **Note Polyseal orientation.**
6. Thread Piston Assembly Tool (123111-2 for 202, 202B & 202V) or (123111-4 for 202L & 202LV) onto Piston (6). Slide complete Gland Assembly and Wiper Seal (9) onto Piston (6).

7. Install assembled components in gently from rear of tool using a press as shown in (Figure 8).

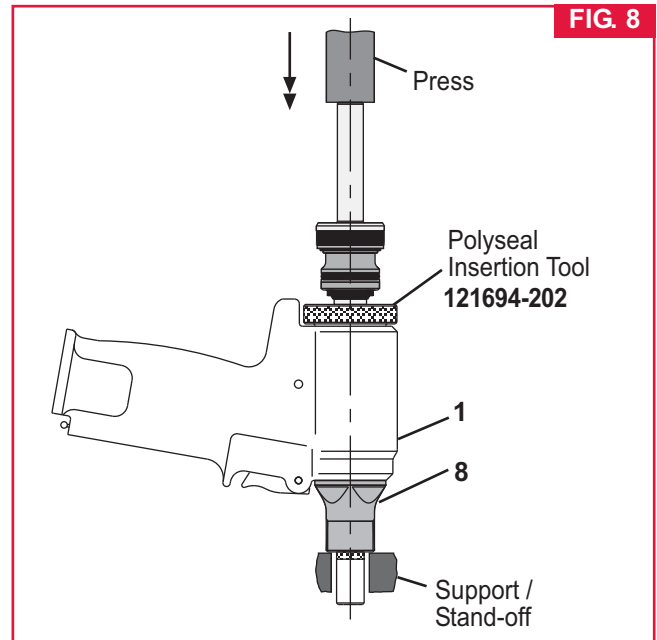

8. Remove Piston Assembly Tool (123111-2 or 123111-4) and POLYSEAL Insertion / removal (121694-202) Tool.
9. Install Rear Wiper Seal (23) into End Cap (21) (Figure 14).
10. Slide Spacer (22) and Spring (19) into End Cap (21) and then thread End Cap assembly into rear of Head. **NOTE:** For 202V and 202VL, please reference Assembly of Pintail Bottle and Vacuum System procedure.

### General:

(Refer to Figures 2 & 14)

11. Hold Head/Handle (1) inverted in vice (with soft jaws). Place inverted Cylinder Assembly (35) on base of handle. Timing pin maintains orientation.
12. Assemble Gland assembly (25) with new seals (Fig. 9). Note orientation of polyseal. Apply Anti-Seize Compound (Huck P/N 508183) to threads of Gland Assembly. Screw gland into head/handle and Torque to 50 ft. lbs. using 1 3/8 socket wrench.(40) using 1/8 hex key (Fig. 2).





## ASSEMBLY - ALL MODELS *continued*

13. Push Bumper (34) firmly over gland.  
**NOTE:** The side of the bumper with two slots must face toward the bottom of the tool.
14. Install Quad Ring (47) onto Air Piston (37).
15. Lubricate piston rod. Press assembled air piston/rod into cylinder just enough to allow installation of cylinder head (45).
16. Assemble O-Ring (46) onto Cylinder Head (45) and then push Cylinder Head squarely into cylinder taking care not to damage O-ring (46). Install Retaining Ring (38). (*Align screw holes with muffler end cap*)
17. Position Muffler (42) in center of cylinder head. Position Gasket (39) on cylinder. ( Refer to Fig 2 & 7) Note direction of Lip
18. Carefully position Bottom Plate (41) on cylinder.  
**NOTE:**  
Make sure that the muffler is properly positioned in recess of Bottom Plate (41) ( Fig 2 & 14).
19. Secure the bottom plate with the three Button Head Screws (40) using 1/8 hex key (Fig. 2).
20. Assembly O-Rings (72 & 50) on Throttle Valve (52) (Fig. 14 Section CC)
21. Place the tool upright on a level surface, drop Spring (49) into throttle valve bore in cylinder (35). Push Throttle Valve into cylinder.
22. Place ball end of Throttle Cable (2) into end of Throttle Arm (53), then slide Throttle Arm into slot on Cylinder (Fig. 14).
23. Snap Lever Guard (73) in place, and install Pivot Screw (48) in cylinder to retain throttle arm (53).
24. **202 & 202L:** Push Pintail Deflector (24) onto End Cap (21).  
**202B:** Position Adapter (64) and Pintail Bottle (24) on End Cap and, by reaching through the window of the Pintail Bottle, install Washer (63) and Retaining Ring (62) (Figures 14 & 15).  
**202V & 202LV:** Please reference Disassembly of Pintail Bottle and Vacuum System Procedure.
25. Tool is now completely assembled and needs to be filled with oil. Please refer to the fill and bleed section next.

### ***Pintail Bottle/Vacuum 202V & 202LV:***

(Refer to Figures 6 & 15 )

The following steps are for the assembly of the 2025V & 2025LV models only. Please use these steps in conjunction with the General and Head/Handle disassembly sections of this manual.

1. Assemble Adapter and Tube/Side Assembly (70) and new O-Rings (65).
2. From bottle side of End Cap (21) install O-Ring (69), Washer (71), Wiper Seal (23), Wiper Housing (67) and Retaining Ring (66) as shown in (Fig. 6).
3. From tool side of end cap install O-Ring (68), Spacer (22) and Spring (19). (as shown in Fig. 6) Screw entire assembly into head and tighten.
4. Assemble Tube/Slide Assembly and O-rings (65), slide complete assembly onto End Cap (21) and push tube into connector (54) (Fig.15).
5. Position Adapter (64) and pintail bottle (24) on End Cap (21) (Fig. 5 & 15).
6. By reaching through the window of the Pintail Bottle (24), install Washer (63) and Retaining Ring (62) as shown in (Fig. 5).



## FILL AND BLEED - ALL MODELS

### Equipment Required:

- Shop airline with 90 - 100 psi max.
- Air regulator
- Fill bottle, 120337, (supplied with tool).
- Large flat blade screwdriver
- Optional Stall Nut 124090 or 125340
- Nose assembly
- Fasteners (optional)



**WARNING: Avoid contact with hydraulic fluid. Hydraulic fluid must be disposed of in accordance with Federal, State and Local Regulations. Please see MSDS for Hydraulic fluid shipped with tool.**

### Preparation:

- Install air regulator in airline and set pressure to 20-40 psi.
- Fill bleed bottle almost full of DEXRON III ATF or equivalent.

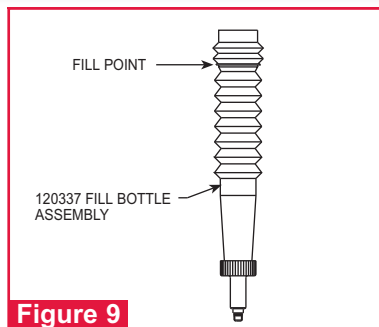

Figure 9



**CAUTION: Refill using Automatic Transmission Fluid DEXRON III or equivalent for optimal performance.**

### Step 1

With fill port facing up, lay tool on it's side, and remove bleed plug (55) from bleed port.

### Step 2

Connect tool to shop air set at 20 to 40 psi. If fluid is present, hold tool over suitable container with fill port facing into container. Cycle tool several times to drain the old fluid, air and foam (Fig. 10)



**WARNING: WARNING: Air pressure MUST be set to 20 to 40 psi to prevent possible injury from high pressure spray. If plug (55) is removed, fill bottle must be in place before cycling tool.**

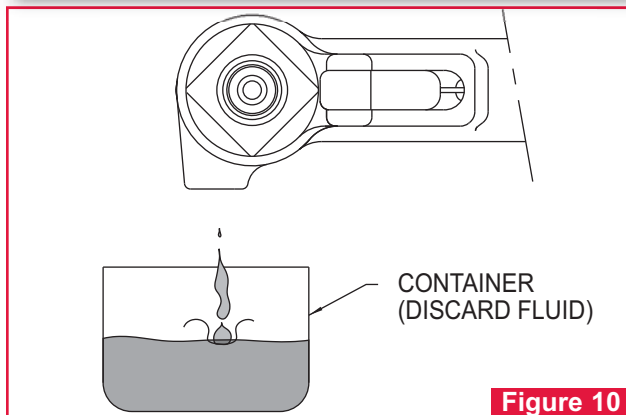

Figure 10



**CAUTION: All oil must be purged from tool before Fill & Bleed process. Tool stroke will be diminished if oil is aerated.**

### Step 3

Screw fill bottle (120337) into fill port.

### Step 4

Stand tool upright on bench. While triggering tool slowly (20 - 30 cycles), bend fill bottle at right angles to tool (Fig. 11). Air bubbles will accumulate at top of the bottle. When bubbles stop, cycling may be discontinued.

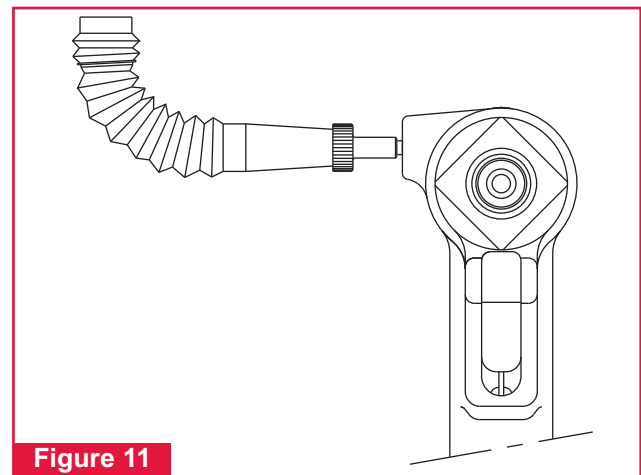

Figure 11

### Step 5

When trigger is released, pull piston returns to idle position (full forward). Disconnect tool from airline.

### Step 6

Lay tool on it's side and remove fill bottle. Top off fluid in fill port, install bleed plug and tighten.

### Step 7

Connect airline to tool and measure the tools stroke, refer to the Measuring Tool Stroke section. If stroke is less than specified, remove bleed plug and top off fluid. Reinstall bleed plug and recheck stroke.

### Step 8

Increase air pressure to specifications. Install two fasteners to check function and installation in a single stroke, or cycle tool with stall nut fully threaded onto piston to load up tool. Measure stroke again. Remove plug and top off fluid. Reinstall plug and cycle and measure again. Continue this process until stroke meets minimum requirements.



## MEASURING TOOL STROKE

FIG. 12

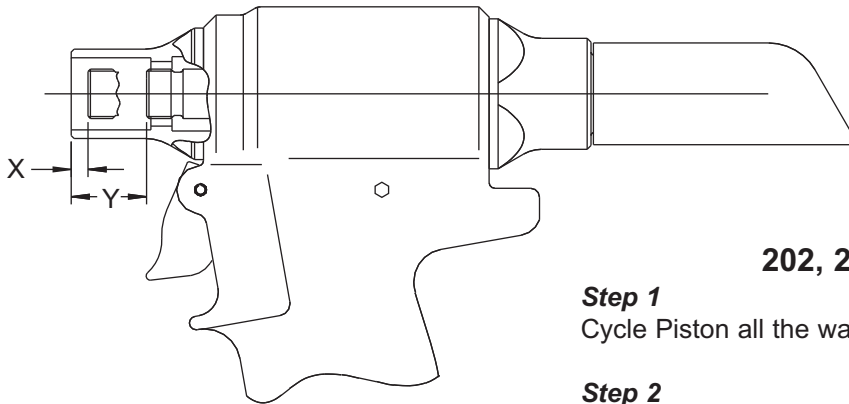

### 202, 202B, & 202V

**Step 1**

Cycle Piston all the way forward and measure X.

**Step 2**

Cycle and hold piston back and measure Y.

**Step 3**

Stroke = Y-X

FIG. 13

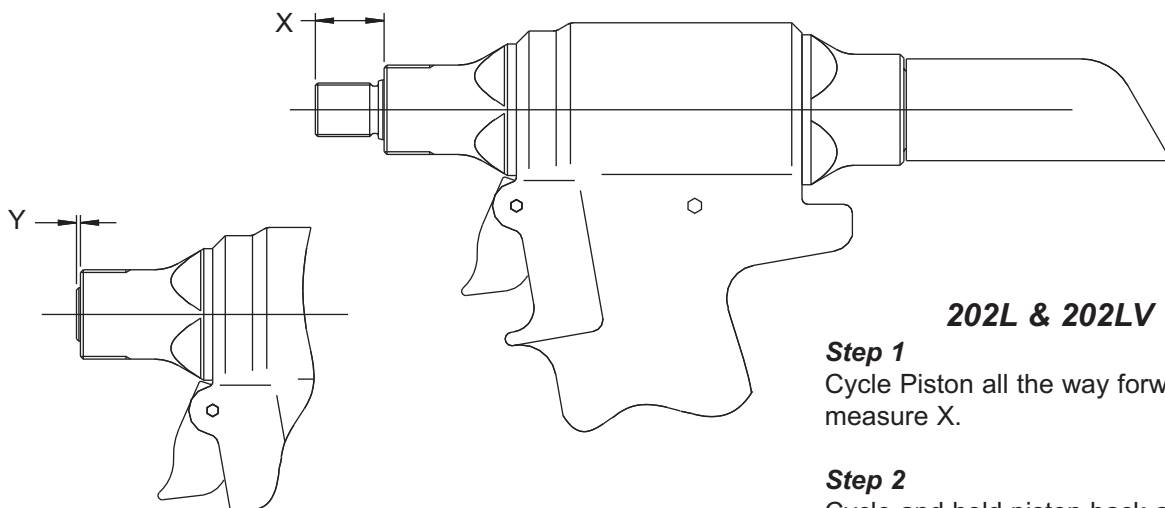

### 202L & 202LV

**Step 1**

Cycle Piston all the way forward and measure X.

**Step 2**

Cycle and hold piston back and measure Y.

**Step 3**

Stroke = X-Y



FIG. 14

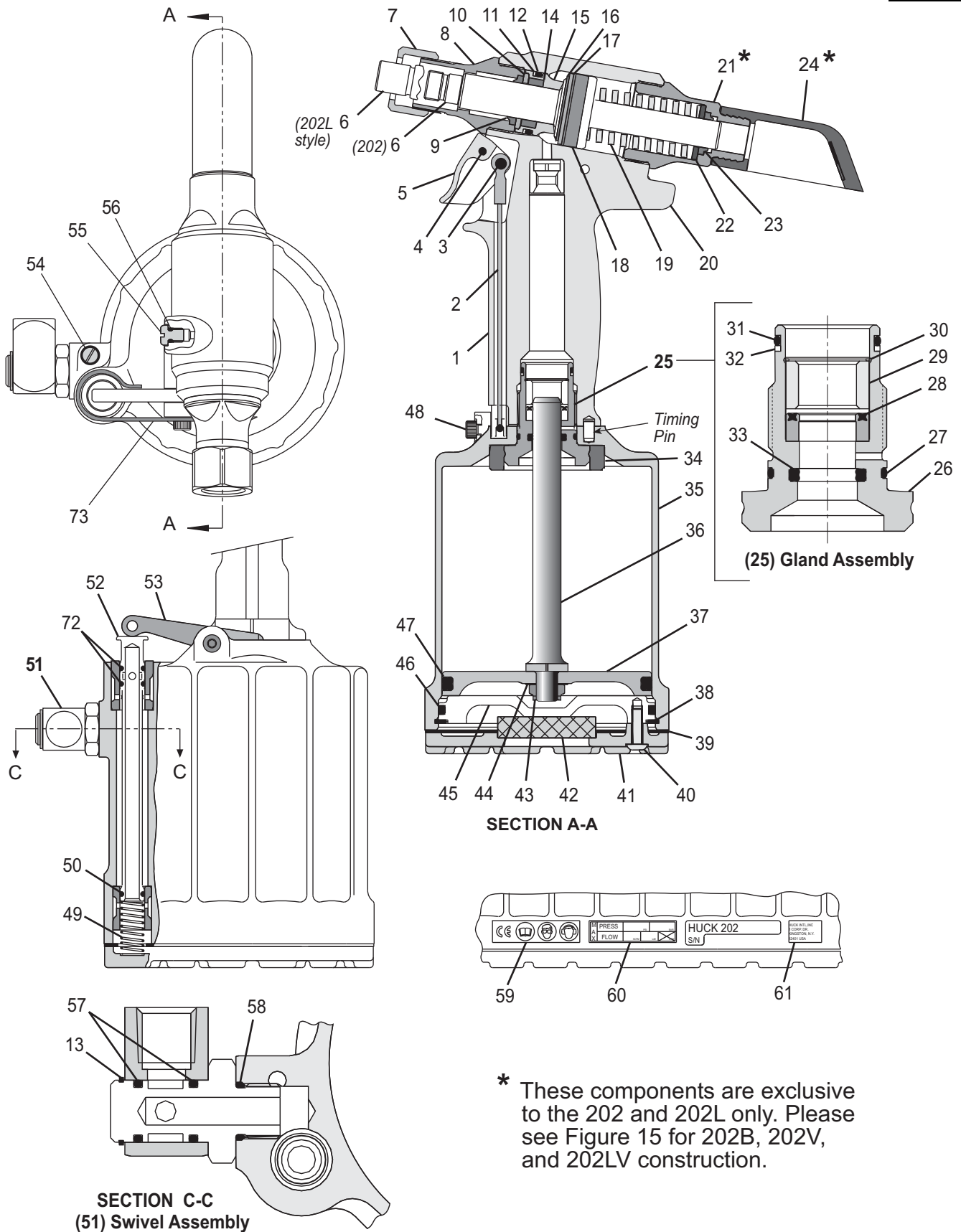

\* These components are exclusive to the 202 and 202L only. Please see Figure 15 for 202B, 202V, and 202LV construction.



FIG. 15

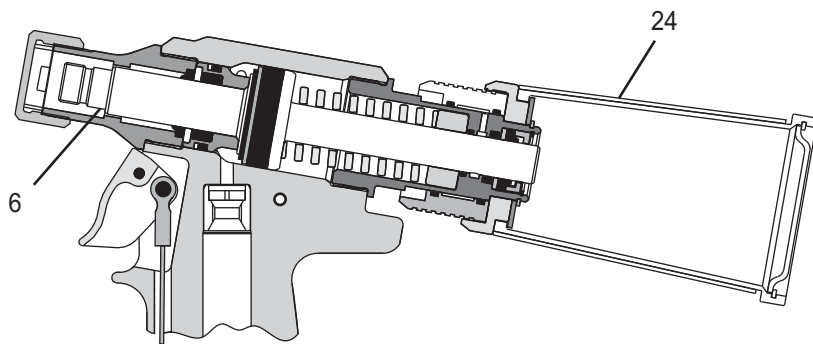
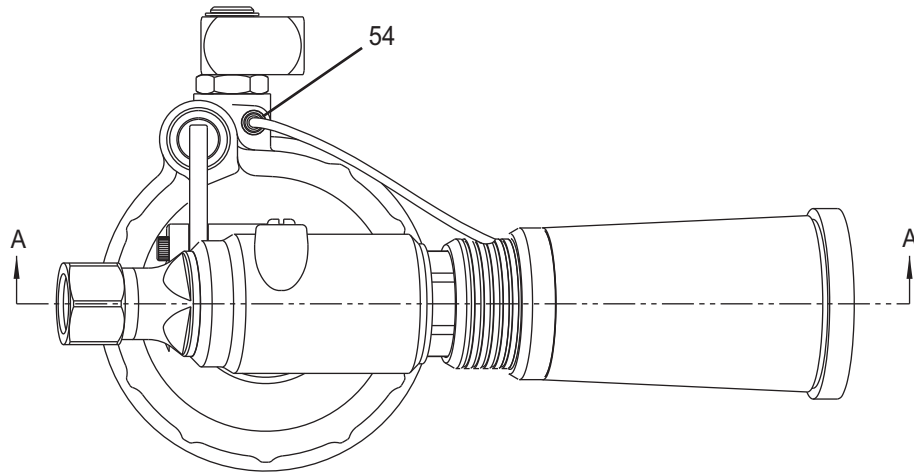

PARTIAL SECTION A-A  
Bottle Unit 202B

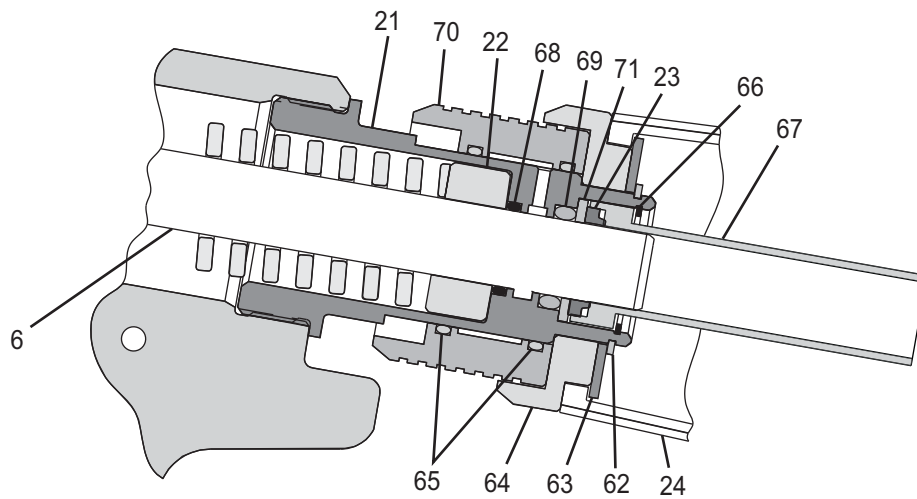

PARTIAL SECTION A-A  
Vacuum Units 202V and 202LV



## PARTS LIST

Item	Description	Qty	202	202L	202B	202V	202LV
1*	Handle Assembly	1			128178		
2	Cable Assembly	1			116404-1		
3	Dowel Pin	1			505496		
4	Pin	1			500621		
5	Trigger	1			124333-1		
6	Piston Assembly (incl. items 16,17,&18)	1	123774	125495	123774	123774-1	125495-1
7	Retaining Nut	1			111795		
8	Adapter	1			123761		
9	Wiper Seal	1			505817		
10	Gland Cap	1			122432		
11	Back-up Ring	1			501110		
12	O-Ring	1			500816		
13	Retaining Ring	1			502274-		
14	Polyseal	1			505818		
15	Front Gland	1			123757		
16	Retaining Ring	1			506653		
17	Washer	1			506654		
18	Polyseal	1			506160		
19	Compression Spring	1			506492		
20	WARNING Sticker	1			590240-1		
21	End Cap	1	125150		124341	123577	
22	Spacer / Washer	1			124828		
23	Wiper Seal	1			506488		
24	Pintail Deflector / Bottle	1	124211			123772	
25	Gland Assembly	1			116134-1		
26	Gland Housing	1			125139		
27	O-ring	1			500786		
28	Polyseal	1			506566		
29	Spacer	1			123906		
30	Retaining Ring	1			506565		
31	O-ring	1			500784		
32	Back-up Ring	1			501090		
33	QUAD Ring	1			501414		
34	Bumper	1			116408		
35*	Cylinder Assembly	1			123752		
36	Piston, Rod	1			111803-1		
37	Air Piston	1			123753		
38	Retaining Ring	1			506490		
39	Gasket	1			126941-1		
40	Screw	3			504127		

\* When replacing Cylinder Assembly (35) Stickers (59, 60, & 61) MUST be ordered and placed in the location shown in Figure 14.

\*\* When replacing Handle Assembly (1), WARNING Sticker (20) MUST be ordered and placed in the location shown in Figure 14.





## PARTS LIST *continued*

Item	Description	Qty	202	202L	202B	202V	202VL	
41	Bottom Plate	1			128790			
42	Muffler	1			115554-1			
43	Locknut	1			505420			
44	Washer	1			506493			
45	Cylinder Head	1			111959-1			
46	O-ring	1			500869			
47	QUAD Ring	1			501456			
48	Pivot Screw	1			125118			
49	Spring	1			116272			
50	O-ring	1			504407			
51	Swivel Assembly	1			507164			
52	Throttle Valve	1			115505-1			
53	Throttle Arm	1			123754			
54	Plug/Gasket Assy; Tubing Connector (V models)	1		506576		506675		
55	Bleed Plug	1	Sold as an assembly only: Bleed Plug Assy part no. 104293					
56	O-ring	1						
57	O-ring	2			500779			
58	O-ring	1			500778			
59	CE Sticker	1			590350			
60	Max Pressure & Flow Sticker	1			590351			
61	HUCK Address Sticker	1			590347			
62	Retaining Ring	1	-----			501007		
63	Washer	1	-----			506628		
64	Adapter	1	-----	----		123784		
65	O-ring	2	-----			500790		
66	Retaining Ring	1	-----			502310		
67	Tube	1	-----			128186		
68	O-ring	1	-----			500778		
69	O-ring	1	-----			500807		
70	Tube and Slide Assy Replacement Tube part no. 128043 may be purchased separately.	1	-----			128044		
71	Washer	1	-----			506648		
72	O-ring	2			504408			
73	Lever Guard	1			125117			
74	Rotatable Stop	1			120588			
75	Sticker, Year of Manufacture	1			590517			



## TROUBLESHOOTING

Always check out the simplest possible cause of a malfunction first. For example, an air hose not connected. Then proceed logically, eliminating each possible cause until the cause is located. Where possible, substitute known good parts for suspected bad parts.

### 1. Tool fails to operate when trigger is depressed:

- a) Air line not connected or pressure too low.
- b) Throttle Valve O-rings (50) worn or damaged.
- c) Throttle Valve Cable (2) is broken.

### 2. Tool does not complete fastener installation and break pintail:

- a) Air pressure too low
- b) Air Piston Quad-ring (47) worn or damaged.
- c) Tool is low on hydraulic fluid, refer to Fill and Bleed section.
- d) Air in hydraulic system, refer to Fill and Bleed section.

### 3. Pintail stripped and/or swaged collar not ejected:

- a) Check for broken or worn jaws in nose assembly, refer to nose assembly data sheet.
- b) Check for worn anvil, refer to nose data sheet.

### 4. Hydraulic fluid exhausts with air or leaks at base of handle:

- a) Worn or damaged Gland Assembly (25), inspect Polyseal (28), O-rings (31 and 27), Quad-ring (33) and Back-up ring (32) replace if necessary.

### 5. Hydraulic fluid leaks at rear of Pull Piston (6):

- a) Worn or damaged piston Polyseal (18), replace if necessary.

### 6. Hydraulic fluid leaks at front of Pull Piston (6):

- a) Worn or damaged Front Gland (15), inspect Polyseal (14), O-ring (12) and Back-up Ring (11) replace if necessary.

### 7. Pull Piston (6) will not return:

- a) Throttle Valve (52) stuck: Lubricate O-rings (50).
- b) Throttle Arm (53), Cable (2) or Trigger (5) binding.

### 8. Air leaks at air Cylinder Head (45):

- a) Worn or damaged O-ring (46) replace if necessary.

## KITS AND ACCESSORIES

<b>Fill and Bleed Bottle</b> (Fig. 9)	- 120337	<b>Suspension Spring</b>	- 124447
<b>Stall Nut</b> (202, 202B, & 202V)	- 124090	<b>Pintail Collection Bag</b> (202 & 202L)	- 125652
<b>Stall Nut</b> (202L & 202LV )	- 125340	<b>Conversion Kit</b>	- 124173
<b>202, 202B, &amp; 202V</b>		<i>(To convert 202 to 202V)</i>	
<b>Assembly Tool Kit</b>	- 123110-2	<i>Includes:</i>	
<i>Includes: (Fig. 3)</i>		Piston Assembly 202V	- 123774-1
Piston Assembly (Bullet)	- 123111-2	End Cap Assembly	- 124246
Spacer	- 123112-2	Tubing & Slide Assembly	- 124245
POLYSEAL Tool	- 121694-202	Straight Connector	- 506675
		Vacuum Attach Adapter	- 123784
<b>202L &amp; 202LV</b>		Pintail Collection Bottle	- 123772
<b>Assembly Tool Kit</b>	- 123110-8	Flat Washer	- 506628
<i>Includes: (Fig. 3)</i>		Retaining Ring Ext	- 501007
Piston Assembly (Bullet)	- 123111-4	<b>1/8 Hex Key</b> (used on Item 40, fig 14)	- 502294
Spacer	- 123112-3	<b>5/32 Hex Key</b> (used on Item 48, fig 14)	- 502295
POLYSEAL Tool	- 121694-202		
<b>Service Kit</b> (202, 202B, & 202L)	- 202KIT	<b>Retaining Ring Pliers</b>	- 502866
<b>Service Kit</b> (202LV & 202V)	- 202VKIT		



## LIMITED WARRANTIES

### TOOLING WARRANTY:

Huck warrants that tooling and other items (excluding fasteners, and hereinafter referred as "other items") manufactured by Huck shall be free from defects in workmanship and materials for a period of ninety (90) days from the date of original purchase.

### WARRANTY ON "NON STANDARD OR CUSTOM MANUFACTURED PRODUCTS":

With regard to non-standard products or custom manufactured products to customer's specifications, Huck warrants for a period of ninety (90) days from the date of purchase that such products shall meet Buyer's specifications, be free of defects in workmanship and materials. Such warranty shall not be effective with respect to non-standard or custom products manufactured using buyer-supplied molds, material, tooling and fixtures that are not in good condition or repair and suitable for their intended purpose.

**THERE ARE NO WARRANTIES WHICH EXTEND BEYOND THE DESCRIPTION ON THE FACE HEREOF. HUCK MAKES NO OTHER WARRANTIES AND EXPRESSLY DISCLAIMS ANY OTHER WARRANTIES, INCLUDING IMPLIED WARRANTIES AS TO MERCHANTABILITY OR AS TO THE FITNESS OF THE TOOLING, OTHER ITEMS, NONSTANDARD OR CUSTOM MANUFACTURED PRODUCTS FOR ANY PARTICULAR PURPOSE AND HUCK SHALL NOT BE LIABLE FOR ANY LOSS OR DAMAGE, DIRECTLY OR INDIRECTLY, ARISING FROM THE USE OF SUCH TOOLING, OTHER ITEMS, NONSTANDARD OR CUSTOM MANUFACTURED PRODUCTS OR BREACH OF WARRANTY OR FOR ANY CLAIM FOR INCIDENTAL OR CONSEQUENTIAL DAMAGES.**

Huck's sole liability and Buyer's exclusive remedy for any breach of warranty shall be limited, at Huck's option, to replacement or repair, at FOB Huck's plant, of Huck manufactured tooling, other items, nonstandard or custom products found to be defective in specifications, workmanship and materials not otherwise the direct or indirect cause of Buyer supplied molds, material, tooling or fixtures. Buyer shall give Huck written notice of claims for defects within the ninety (90) day warranty period for tooling, other items, nonstandard or custom products described above and Huck shall inspect products for which such claim is made.

### TOOLING, PART(S) AND OTHER ITEMS NOT MANUFACTURED BY HUCK:

**HUCK MAKES NO WARRANTY WITH RESPECT**

**TO THE TOOLING, PART(S) OR OTHER ITEMS MANUFACTURED BY THIRD PARTIES. HUCK EXPRESSLY DISCLAIMS ANY WARRANTY EXPRESSED OR IMPLIED, AS TO THE CONDITION, DESIGN, OPERATION, MERCHANTABILITY OR FITNESS FOR USE OF ANY TOOL, PART(S), OR OTHER ITEMS THEREOF NOT MANUFACTURED BY HUCK. HUCK SHALL NOT BE LIABLE FOR ANY LOSS OR DAMAGE, DIRECTLY OR INDIRECTLY, ARISING FROM THE USE OF SUCH TOOLING, PART(S) OR OTHER ITEMS OR BREACH OF WARRANTY OR FOR ANY CLAIM FOR INCIDENTAL OR CONSEQUENTIAL DAMAGES.**

The only warranties made with respect to such tool, part(s) or other items thereof are those made by the manufacturer thereof and Huck agrees to cooperate with Buyer in enforcing such warranties when such action is necessary.

Huck shall not be liable for any loss or damage resulting from delays or nonfulfillment of orders owing to strikes, fires, accidents, transportation companies or for any reason or reasons beyond the control of the Huck or its suppliers.

### HUCK INSTALLATION EQUIPMENT:

Huck International, Inc. reserves the right to make changes in specifications and design and to discontinue models without notice.

Huck Installation Equipment should be serviced by trained service technicians only.

Always give the Serial Number of the equipment when corresponding or ordering service parts.

Complete repair facilities are maintained by Huck International, Inc. Please contact one of the offices listed below.

#### Eastern

One Corporate Drive Kingston, New York 12401-0250  
Telephone (845) 331-7300 FAX (845) 334-7333

#### Outside USA and Canada

Contact your nearest Huck International Office, see back cover.

In addition to the above repair facilities, there are Authorized Tool Service Centers (ATSC's) located throughout the United States. These service centers offer repair services, spare parts, Service Parts Kits, Service Tools Kits and Nose Assemblies. Please contact your Huck Representative or the nearest Huck office listed on the back cover for the ATSC in your area.

# Applifast.

251 Cree Crescent, Winnipeg, MB Canada R3J 3X4  
Tel: 204 837 8361 • 1 800 563 1293  
Fax: 204 837 3520 • 1 800 974 1494



[applifast.com](http://applifast.com)