



Stationary Transducers

Workbench mounted torque transducer

Key Features

- ✓ Suitable for measurement of all continuous drive and hand torque tools
- ✓ Automatic transducer recognition with Crane readout devices (Auto ID)
- ✓ Combine with joint kits for workshop simulation of hard to soft joints
- ✓ Incorporate into custom built mobile test stations



Product Overview

Crane's stationary transducers are the quality choice for the testing of all continuous drive, impulse and hand torque tools in the workshop and production line-side environment.

Stationary transducers are used off the production line in workshop or line-side test stations. Combined with joint kits that represent the production joint condition, the stationary transducers form an effective off line test for verification of assembly tool performance.

Stationary transducers form an essential part of the Crane UTA torque system, enabling automatic transducer recognition with Crane readout devices. On board intelligence means the UTA transducer is automatically recognised by the Crane readout device, eliminating set-up errors and enabling logging of serial number against measurements for complete traceability. An Industry Standard (IS) version is also available, where a user needs the features of the stationary transducer but already has a readout device from another manufacturer.

Stationary Transducers Technical Specification

Transducer Type	UTA: incorporate data chip enabling automatic transducer recognition operation with Crane readout devices I.S: 'Industry Standard' version Bridge resistance: 350 Ohms Sensitivity: 2mV/V
Construction	Steel housing Overload capacity: 125% rated torque Square drives to ANSI B107-4 -1982; BS4006 – 1992; DIN 3121 – 1987
Connections	UTA: 1m integral cable with strain relief; 25-pin 'D' port (male) for connection to CEL readouts I.S: output connector to MIL –C 26482 / BS 9522 FOO 17; shell size 8 -4P
Zero stability	< $\pm 0.1\%$ of FSD/°C
Static accuracy	$\pm 0.25\%$ FSD
Operating Environment	Temperature: 5 -40°C (-10 to 60°C with reduced specification) Humidity: 10 – 75% non-condensing Ingress Protection rating: IP40
Warranty	12 months parts and labour against faulty workmanship or materials
Calibration	All torque equipment should be re-calibrated every 12 months

Weights and dimensions

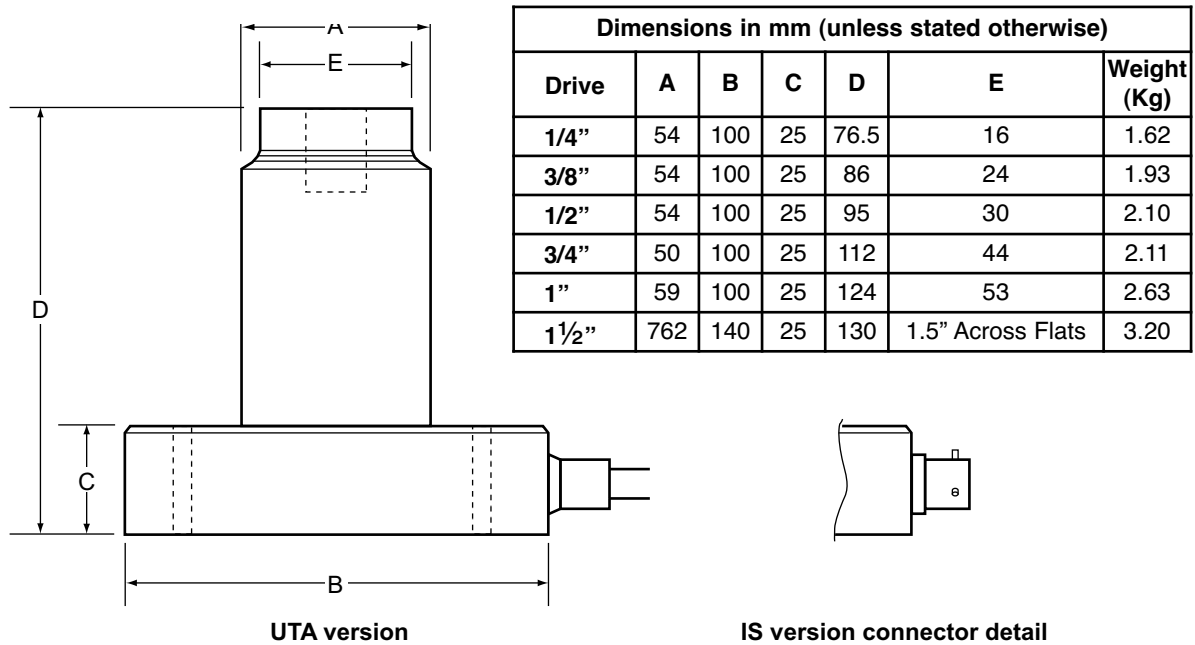

Product Codes

Order Code	Drive	Nominal Torque	
		Nm	Imperial (ftlbf)
UTA Statics			
UTA-164-0-3.54-0-0	1/4"	3.54	31.36 inlbf
UTA-164-0-25	1/4"	5.65	50 inlbf
UTA-165-0-25	1/4"	11.3	100 inlbf
UTA-166-0-25	1/4"	28	250 inlbf
UTA-167-0-35	3/8"	68	50
UTA-168-0-35	3/8"	135	100
UTA-169-0-35	1/2"	271	200
UTA-170-0-35	3/4"	542	400
UTA-171-0-35	3/4"	1017	750
UTA-172-0-35	1"	1695	1250
UT-115-00CR-3000-0*	1 1/2"	3000	2213
IS Statics – 2 mV/V Sensitivity			
IS-873-08CR-11-0	1/4"	11.3	100 inlbf
IS-873-10CR-28-0	1/4"	28.25	250 inlbf
IS-873-12CR-67-0	3/8"	67.8	50
IS-873-14CR-135-0	3/8"	135.6	100
IS-873-16CR-271-0	1/2"	271.2	200
IS-873-18CR-1017-0	3/4"	1017	750
IS-873-20CR-1695-0	1"	1695	1250

*Male square drive

Applifast.

251 Cree Crescent, Winnipeg, MB Canada R3J 3X4
Tel: 204 837 8361 • 1 800 563 1293
Fax: 204 837 3520 • 1 800 974 1494



applifast.com